

Cover page

Title: Design of a Wireless Sensor for Scalable Distributed In-Network Computation in a Structural Health Monitoring System, Proceedings of the 5th International Workshop on Structural Health Monitoring 2005

Authors: R. Andrew Swartz
Deokwoo Jung
Jerome P. Lynch
Yang Wang
Dan Shi
Michael P. Flynn

ABSTRACT

The common deterioration of civil infrastructure systems and the threat of extreme loadings require facility managers to improve their knowledge regarding the health of the structures that they manage. A dense array of wireless sensors installed in a structure could provide ample amounts of empirical data for monitoring structural health. In addition to being a low cost alternative to traditional cable-based monitoring systems, wireless sensor networks offer a distributed computing paradigm that allows sensors to self interrogate structural response data. In this paper, improvements are made to an existing wireless sensing unit to enhance its measurement accuracy and to render it better suited for in-network data processing. In particular, the proposed wireless sensor is an improvement over previous designs since it is constructed using a compact four layer printed circuit board. Furthermore, the wireless sensor utilizes an implementation of the IEEE 802.15.4 standard for wireless networks allowing it to participate in scalable, peer-to-peer communication that is adaptable to network changes without requiring reprogramming.

INTRODUCTION

The structural state of our nation's infrastructure is deteriorating, but so too is the ability of the nation to pay for its continual maintenance and repair. An in depth study of highway bridges in the United States reveals that nearly 45% of the nation's bridges are structurally deficient or functionally obsolete [1]. In the case of catastrophic events including earthquakes, tsunamis, and terrorist attacks, it is essential that emergency responders have available to them real-time information regarding the condition and safety of the structures for which they are responsible. Visual inspection is time consuming and costly; recently, a single inspection of the main

Andrew Swartz, Department of Civil & Environmental Engineering, University of Michigan
Deokwoo Jung, Department of Electrical Engineering & Computer Science, University of Michigan
Jerome Lynch, Department of Civil & Environmental Engineering, University of Michigan
Yang Wang, Department of Civil & Environmental Engineering, Stanford University
Dan Shi, Department of Electrical Engineering & Computer Science, University of Michigan
Michael Flynn, Department of Electrical Engineering & Computer Science, University of Michigan

cable system of the Golden Gate Bridge in San Francisco incurred a cost of \$226,900 [2]. To achieve these goals economically, sensors permanently installed in critical infrastructure systems are required. To date, the majority of structural monitoring systems installed in structures utilize extensive lengths of cables to communicate sensor data to a centralized data server. Traditional wired sensors are difficult and expensive to install, especially retroactively into an existing structure. It has been shown that the installation of wired sensors can cost thousands of dollars per sensor channel [3].

As a substitute to cable-based monitoring technologies, wireless sensor networks have recently emerged. Wireless sensors are an exciting monitoring technology due in part to their low cost and autonomous functionality. The structural engineering community has undertaken many studies that assess their utility for structural monitoring applications [4]. To date, a number of academic and commercial wireless sensor prototypes have been proposed with many installed in a variety of laboratory and field structures. For example, wireless structural monitoring systems have been successfully installed to monitor the Alamosa Canyon Bridge, New Mexico (with 7 units installed) and the Guem dang Bridge, Korea (with 14 units installed) [5,6]. An important aspect of wireless sensors that sets them apart from their tethered counterparts is the collocation of computing power with the sensor. This allows the wireless sensor to assume responsibility for processing measurement data. A number of embedded algorithms have been proposed for wireless sensors including those geared towards system identification and damage detection [4].

The performance requirements of wireless sensors intended for structural monitoring are many. First, the wireless sensors must be inexpensive in order to make economically feasible dense arrays of sensing units, perhaps hundreds of nodes in a single structure. Because wireless sensors have a limited power supply, usually an on-board battery pack, they must be able to operate with low power consumption and be programmed with efficient power management algorithms. More effective computing methods for damage detection can be achieved using wireless sensing units capable of peer-to-peer collaboration and distributed in-network computation. To achieve this, the communication range of the sensors must be sufficiently adequate as to allow optimal spacing of the sensing units, unrestricted by their effective communication range. To be power efficient, such a system requires the minimization of communication between sensors as, generally, the radio is the greatest consumer of power within the unit [7]. Finally, future wireless monitoring systems must be completely scalable, not restricted in terms of size or number of wireless sensor nodes.

In this paper, a new design for a wireless sensor is proposed to better meet the performance specification described above. In particular, the new wireless sensor prototype described herein is intended to attain performance gains over previous designs in three major areas: 1) the prototype wireless sensor will achieve greater measurement fidelity by improving the circuit environment for the analog-to-digital converter, 2) will further reduce the power consumption by adopting a low-power wireless radio, and 3) offer an improved wireless communication protocol standard offering accurate time synchronization and network scalability. In particular, the prototype unit is partially based on a previous design proposed by Wang, et al [8] and utilizes a four layer circuit board as opposed to the two layer board used previously. Additionally, a new radio is used that has lower power requirements than the previous

unit and is IEEE 802.15.4 compliant. Adoption of this standard allows end-users to take full advantage of the distributed computing architecture offered by a wireless sensor network.

WIRELESS SENSOR HARDWARE DESIGN

As proposed for other wireless sensor prototype designs, the hardware design of the wireless sensor is broken down into three major subsystems. First, a sensing interface is proposed for the collection of structural response data from multiple analog sensors (accelerometers, strain gages, displacement transducers). The next subsystem is the computational core which receives the sensor data in digital form from the sensing interface. The core is chiefly responsible for data management and execution of preprogrammed data interrogation tasks. Finally, when data is ready for communication (transmit or receive), the wireless communication subsystem provides for the connection to other wireless sensors in the network.

The new sensing unit presented in this paper features two notable improvements in its hardware design over a similar unit initially proposed by Wang, Lynch and Law [8]. First, a low-power, single-chip, IEEE 802.15.4 compliant wireless radio is adopted in the wireless sensor design. The newly created IEEE 802.15.4 standard is especially suitable for distributed computation, as it was developed for true ad-hoc peer-to-peer networking among battery powered wireless devices. The second most significant improvement is the use of a four layer circuit board, replacing the more limited two layer boards in use today. Two major advantages are realized by upgrading from a two layer circuit board to a four layer board. First, four layer boards allow for more compact designs as they provide more options for routing circuit connections. The second advantage is the ability to devote the internal layers of the board to power and grounding planes. Using an internal layer solely for power planes result in more efficient distribution of power than trace conductors in addition to also dissipating waste heat quickly. Due to the mixture of digital (*e.g.* microcontroller) and analog (*e.g.* analog-to-digital converter (ADC)) circuit elements on the same circuit board, it is desirable to separate the common ground for the analog components from the ground utilized by the digital components. Digital components on previous two-layer board designs have shown a tendency to flood the ground resulting in a loss of ADC resolution. For example, a previous design utilized a 16-bit ADC converter, but due to the flooding of a shared ground plane, the resolution realized was reported as closer to 14-bits [9]. For the four layer design, the grounding planes have been enlarged and planes for the analog components are separated from the digital components resulting in a higher resolution for the ADC [10]. Straser and Kiremidjian [11] have also reported the attainment of the true ADC resolution by utilizing a four layer printed circuit board for their ADC.

The complete hardware design of the proposed wireless sensor is presented in Figure 1(a). The primary component of the sensing interface is a four-channel, 16bit, 100 kHz ADC (Texas Instruments ADS8341). With four channels, the sensing interface is capable of supporting four analog sensors simultaneously. The interface is capable of accepting analog signals between 0 and 5V. This combination of resolution and input voltage range allows the sensing interface to adequately handle a wide

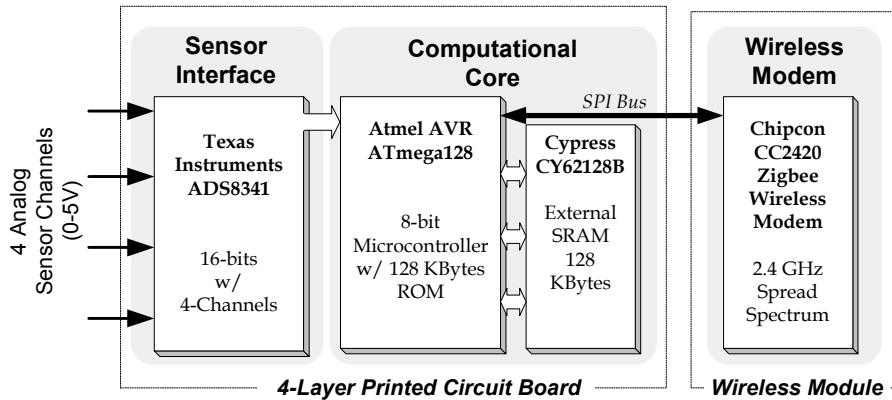

(a)

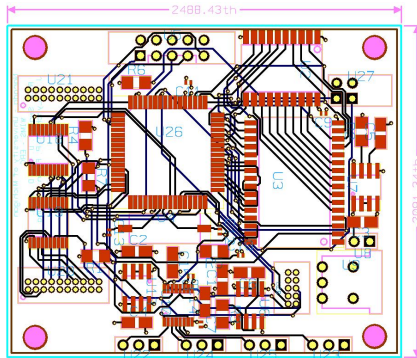

(b)

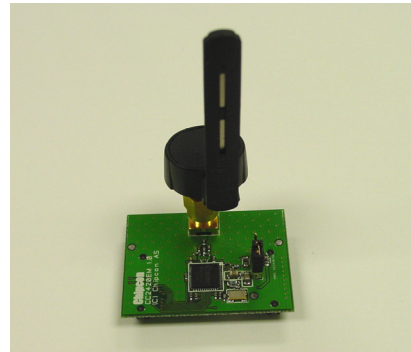

(c)

Figure 1. (a) Architectural overview of wireless sensor hardware design. (b) 4-layer printed circuit board design. (c) IEEE 802.15.4 compliant wireless modem module (Chipcon CC2420)

variety of sensors for most structural health monitoring purposes [8]. The upgrade to a four layer board allows for a more ideal separation of power supply and ground for the analog and digital components. The wireless sensing unit has at its core a low voltage microcontroller which is used to coordinate all of the parts of the unit as well as to perform data interrogation tasks. The microcontroller selected is the 8-bit Atmel ATmega128 microcontroller which, at a system clock of 8MHz, consumes less than 20mA of current with a 5V supply voltage [12]. The ATmega128 provides a flash memory of 128kB, adequate for most embedded software algorithms required for structural engineering applications. To augment the built in 4kB of SRAM, external memory of 128kB is provided using a Cypress CY62128B SRAM chip. This is adequate for the data storage and analysis requirements of the sensing unit. The electrical circuit elements selected for the sensing interface and the computational core are designed for placement upon the four layer printed circuit board. A picture of the final circuit board design (currently being manufactured) is shown in Figure 1(b).

For the wireless communication system, the Chipcon CC2420 is selected. The CC2420 is a single chip IEEE 802.15.4 compliant radio capable of providing communication with ranges adequate for civil infrastructures. For example, its operational indoor communication range is validated up to 20 m. Furthermore, the radio operates on the 2.4 GHz internationally unregulated radio band with data rates as high as 250kpbs. Because the CC2420 is designed specifically to be IEEE 802.15.4 compliant, it does not require the use of a central processor to facilitate

communications; the sensing units may communicate directly with each other making them ideal for peer-to-peer communications. While the sensing interface and computational core elements reside on the 63 mm by 53 mm four layer printed circuit board, the CC2420 wireless radio is included as part of the Chipcon CC2420EM evaluation board, which includes the CC2420 radio in addition to supporting discrete elements and an antenna (see Figure 1(c)). Sockets are included in the four layer printed circuit board to allow the CC2420 evaluation board to connect.

The CC2420EM daughter board requires a supply voltage of 3.3V. The remaining elements in the wireless sensor design all operate at 5V. This fact, combined with the desire to separate the power supply for digital and analog components, necessitates the use of three power domains, one at 3.3V for the radio, one at 5V for the analog portion of the ADC, and one more at 5V for the remainder of the board. This is accomplished by the use of three Texas Instruments LP2986 voltage regulators. In order to allow the CC2420 radio to communicate digitally with the Atmega128 microcontroller, two level shifters, Maxim MAX3008 and MAX3009, are used. The new sensing unit is designed to be powered by 5 AA batteries.

SCALABLE PEER-TO-PEER COMMUNICATION SOFTWARE

The wireless sensing unit proposed in this paper is designed with distributed computing in mind. To facilitate peer-to-peer computing, the unit is programmed with a direct implementation of the IEEE 802.15.4 standard for wireless communication. The IEEE 802.15.4 standard defines the protocol and interconnectedness of wireless devices for a flexible, Low-Rate, Wireless Personal Area Network (LR-WPAN). The features of a LR-WPAN utilizing this standard are wireless connectivity over short ranges, low cost to build, easy installation, reliable data transfer, and efficient use of battery power [13]. This is especially useful for sensor arrays, as the installed network is not limited in size or by specific component requirements. Sensors can be added to or removed from an existing network at will.

The IEEE 802.15.4 specification supports both star and peer-to-peer network topologies. In a star topology, one network device is designated as the central controller for communications (denoted as the personal area network (PAN) coordinator) while the remaining devices in the network communicate through it. Star networks operate independently of one another. In contrast, within a peer-to-peer topology any device can communicate with any other device as long as both devices are within range of one another. Peer-to-peer networks utilizing the 802.15.4 standard also make use of a PAN coordinator, which is usually the device that initiates the network. However, because devices may communicate directly with one another, the role of the PAN coordinator in a peer-to-peer network is significantly reduced from that in the star network [13].

The IEEE 802.15.4 protocol standard for LR-WPAN is concentrated to the two lowest-most layers of the communication protocol stack: physical (PHY) and medium access control (MAC) layers. In total, seven layers are defined by the Open Systems Interconnection (OSI) protocol reference model, with each layer encapsulating a specific functionality of a communication system. The PHY layer is intended to coordinate the physical radio to modulate and demodulate data upon carrier radio

frequencies. The MAC layer offers standard packet structures for data transmission as well as procedural rules for autonomous users to share the common bandwidth. The layer abstraction permits upper layers to have access to services offered by the lower layer through well defined application program interfaces (API).

For the sensor proposed in this paper, three primary layers are defined: the application, medium access control (MAC) and physical (PHY) layers. The application layer is any application the programmer of the network might want to use which will require communication and data transfer between devices in the network; examples might include distributed structural health monitoring algorithms. The application layer can access the MAC layer which controls beacon management, channel access, guaranteed time slot (GTS) management, frame validation, and acknowledged frame delivery. The MAC layer in turn accesses the PHY which controls activation and deactivation of the radio transceiver, energy detection, link quality indication, channel selection, and the act of physically transmitting and receiving packets. The wireless sensor is programmed in such a manner that the user needs only to give commands in the application layer; the MAC and PHY layers will automatically carry out the required functions without additional user commands [14].

An IEEE 802.15.4 compliant radio can operate using either the sixteen channels in the 2.4 GHz industrial, scientific, and medical (ISM) band, the ten channels in the 915 MHz band (only in the US) or using one channel in the 868 MHz band (EU and Japan). The 2.4 GHz band offers the highest data rate and utilizes more channels than the other bands which is beneficial for sensor networks with a high network communication load. For these reasons, the Chipcon CC2420 radio selected operates on the 2.4 GHz band. Since multiple wireless sensors will be sharing the radio bandwidth, the MAC layer provides rules for how sensors can access the channel. The wireless sensor is designed to utilize the radio in a beacon-enabled mode to ensure the network is accurately time synchronized. To ensure no two users use the channel at the same time, channel accesses is coordinated by a slotted carrier sense multiple access – collision avoidance (CSMA/CA) mechanism. According to the slotted CSMA/CA algorithm, a node must sense the channel free at least twice before being able to transmit; this corresponds to the decrement of the so-called contention windows (CW). The first sense must be delayed by a random delay. This randomness serves to reduce the probability of collision when two nodes simultaneously sense the channel, assess it free and decide to transmit at the same time. When the channel is sensed busy, transmission may not occur and the next channel sense is scheduled after a new random delay is computed. When a packet collides or is corrupted, it can be retransmitted after a new contention procedure [14].

Illustration of IEEE 802.15.4 Wireless Connectivity

The PHY and MAC communication protocols are written in a high-level programming language (C) and loaded to the flash memory of the wireless sensor 8-bit microcontroller (Atmel ATmega128). Operated in the laboratory, four wireless sensors are spatially distributed and commanded to form a peer-to-peer network. One unit initiates the establishment of the network and is designated the PAN coordinator. Two other devices are associated with the PAN coordinator and form one communication cluster. The fourth wireless unit is then associated with one of the two

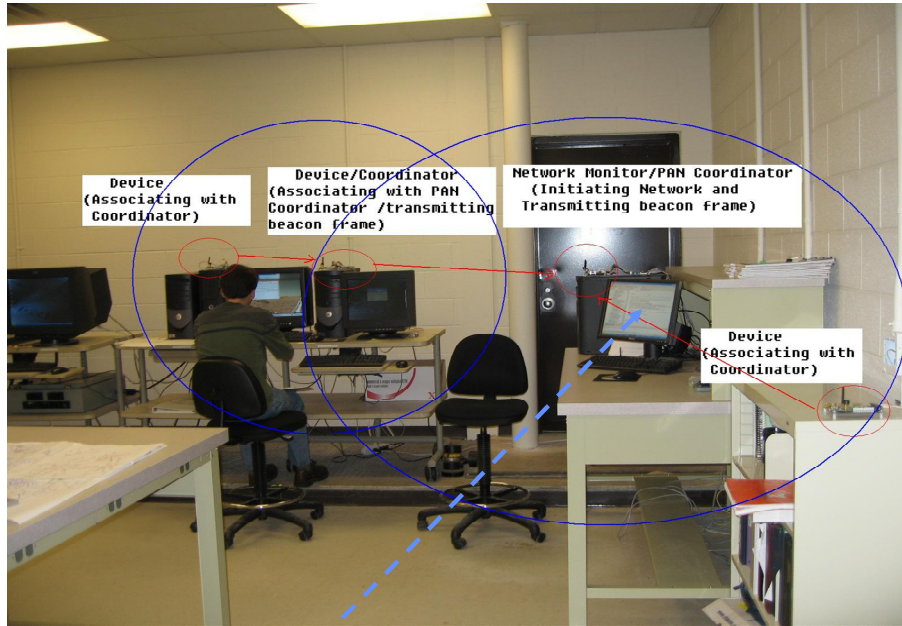

Chipcon Packet Sniffer for IEEE 802.15.4 MAC

Time (us)	Length	Frame control field	Sequence number	Dest. PAN Address	Dest. Address	Source Address	Frame payload	LOI	FCS
+101030 +2028334	31	Type Sec Pnd Ack req Intra PAN	2	0xCDA8	0x3412	0x3412	D2 D2 D2 D2 D2 D2 D2 D2	255	OK
+110169 +2198503	44	Type Sec Pnd Ack req Intra PAN	3	0xCDA8	0x3412	0x7698	B0 B0 F.CAP BLE Coord Assoc	Len Permit Directions List (addr/slot/length)	
+101031 +2239534	31	Type Sec Pnd Ack req Intra PAN	4	0xCDA8	0x3412	0x3412	D3 D3 D3 D3 D3 D3 D3 D3	255	OK
+1615135 +3858669	31	Type Sec Pnd Ack req Intra PAN	1	0xCDA8	0x3412	0x3412	D1 D1 D1 D1 D1 D1 D1 D1	255	OK
+101032 +3955701	31	Type Sec Pnd Ack req Intra PAN	2	0xCDA8	0x3412	0x3412	D2 D2 D2 D2 D2 D2 D2 D2	255	OK
+110172 +4065873	44	Type Sec Pnd Ack req Intra PAN	3	0xCDA8	0x3412	0x7698	B0 B0 F.CAP BLE Coord Assoc	Len Permit Directions List (addr/slot/length)	

Figure 2. Laboratory validation of the full implementation of the IEEE 802.15.4 network protocol embedded in the core of the wireless sensors' Atmel ATmega128 microcontrollers.

devices to form a second cluster. As such, this one wireless sensor is between two clusters and allows for the establishment of communication between clusters. To illustrate all four units can transmit structural response data to one another without error, the wireless devices are queried to exchange their data. Perfect data communication is witnessed with the CSMA/CA mechanism ensuring all of the units can communication harmoniously. An illustration of the laboratory validation study is shown in Figure 2; a screen shot of a packet sniffer that is used to record all of the packets sent in the network, is also shown.

CONCLUSIONS

This paper presents a new wireless sensing unit design that balances the competing requirements for low power consumption, long transmission ranges, and the ability to calculate complicated structural engineering algorithms on-board. The new unit is capable of sensing up to four simultaneous channels from analog sensors and, because of its four layer design, provides a higher resolution for those channels than could previous units. The unit also utilizes the network communication scheme outlined in

the IEEE 802.15.4 standard allowing it to form star and peer-to-peer network topologies. This makes the new unit suitable for distributed computing tasks in dense, ad-hoc networks that are completely scalable. Future work is planned to expand the capabilities of the unit as well as decrease the size. With a very flexible communication architecture now in place, current research is primarily focused upon collaborative decentralized computing permissible within the wireless sensor network. Some additional work is needed to validate the measurement accuracy of the wireless sensor prototype in the laboratory and in the field.

ACKNOWLEDGEMENTS

This research is partially funded by the National Science Foundation Wireless Integrated Microsystems (WIMS) Engineering Research Center. The authors would also like to express their gratitude to Robert Gordenker, University of Michigan for assistance during the design and fabrication of the wireless sensor prototypes.

REFERENCES

1. Coleman, John E. 1995. "Our Aging Infrastructure: Providing for Public Safety and Protecting Public Investment," *Proceedings of SPIE - The International Society for Optical Engineering*, v 2456, pp. 84-91.
 2. Los Alamos National Laboratory. 2003. "A Review of Structural Health Monitoring Literature: 1996-2001," *Los Alamos National Laboratory Report LA-13976-MS*. Los Alamos, NM, USA.
 3. Celebi, M. 2002. "Seismic Instrumentation of Buildings (with Emphasis of Federal Buildings)," *Report No. 0-7460-68170 United States Geological Survey (USGS)*, Menlo Park, CA.
 4. Lynch, J. P., and K. Loh. 2006. "A Summary Review of Wireless Sensors and Sensor Networks for Structural Health Monitoring," *Shock and Vibration Digest*, in press.
 5. Lynch, J. P., A. Sundararajan, K.H. Law, A.S. Kiremidjian, E. Carryer, T.W. Kenny, H. Sohn, C.R. Farrar. 2003. "Field Validation of a Wireless Structural Monitoring System on the Alamosa Canyon Bridge," *Proceedings of SPIE - The International Society for Optical Engineering*, v 5057, pp. 267-278.
 6. Lynch, J. P., Y. Wang, and K. H. Law, J. H. Yi, C. G. Lee, C. B. Yun. 2005. "Validation of Large-Scale Wireless Structural Monitoring System on the Geumdang Bridge," in *Proceedings of 9th International Conference on Structural Safety and Reliability*, Rome, Italy, June 19-23, 2005.
 7. Lynch, J. P., A. Sundararajan, K. H. Law, A. S. Kiremidjian, and E. Carryer. 2004. "Embedding Damage Detection Algorithms in a Wireless Sensing Unit for Attainment of Operational Power Efficiency," *Smart Mater. Struct.*, 13(4): 800-810.
 8. Wang, Y., J. P. Lynch, K. H. Law. 2005. "Design of a Low-Power Wireless Structural Monitoring System for Collaborative Computational Algorithms," *Proceedings of the 23rd International Modal Analysis Conference (IMAC XXIII)*, Orlando, FL.
 9. Lynch, J. P., A. Sundararajan, K. H. Law, H. Sohn, C. R. Farrar. 2004. "Design of a Wireless Active Sensing Unit for Structural Health Monitoring," *Proceedings of SPIE - The International Society for Optical Engineering*, v 5394, pp. 157-168.
 10. Gray, N. C., 1999. "Attack The Noise Gremlins That Plague High-Speed ADCs," *Electronic Design*, pp. 107ff.
 11. Straser, E. G., A. S. Kiremidjian. 1998. "A Modular, Wireless Damage Monitoring System for Structures," Report No. 128, *John A. Blume Earthquake Engineering Center, Department of Civil and Environmental Engineering*, Stanford University, Stanford, CA, USA.
 12. Atmel Corporation. 2004. "Atmel 8-bit AVR Microcontroller with 128k Bytes In-System Programmable Flash," Atmel Corporation, San Jose, CA.
 13. IEEE Computer Society. 2003. IEEE Standard 802.15.4, The Institute of Electrical and Electronics Engineers, Inc. 3 Park Avenue, New York, NY 10016-5997, USA.
 14. Chipcon AS. 2004. "CC2420 2.4 GHz IEEE 802.15.4 / ZigBee-ready RF Transceiver," Chipcon AS, Oslo, Norway.
-