

Piezoelectric Structural Excitation using a Wireless Active Sensing Unit

Jerome P. Lynch

Department of Civil and Environmental Engineering
University of Michigan
Ann Arbor, MI 48109

Arvind Sundararajan, Kincho H. Law

The John A. Blume Earthquake Engineering Center
Stanford University
Stanford, CA 94305

Hoon Sohn, Charles R. Farrar

Engineering Sciences and Applications Division
Los Alamos National Laboratory
Los Alamos, NM 87545

ABSTRACT

Strong interest in applying wireless sensing technologies within structural monitoring systems has grown in recent years. Wireless sensors are capable of passively collecting response measurements of a dynamic structural system at low-costs. However, the role of wireless sensing within structural monitoring systems can be expanded if sensors are provided a direct interface to the physical system in which they are installed. Capable of exciting a structural system through actuators, a wireless “active” sensor would be a valuable tool in structural control and damage detection applications. In this study, a wireless active sensing unit is proposed and fabricated. After fabrication of a prototype, a series of validation tests are conducted to assess the unit’s performance. A piezoelectric pad mounted to an aluminum plate is commanded by the wireless active sensing unit to impart low-energy Lamb waves in the plate surface. Simultaneously, the same unit collects response measurements obtained from a second piezoelectric pad also surface mounted to the plate. To illustrate the potential of the wireless active sensing unit to locally perform system identification analyses, the computational core is provided the task of calculating autoregressive time-series models using input-output time-history data collected from the excited system.

INTRODUCTION

Civil structures including bridges, buildings and pipelines, are expensive assets often exposed to harsh loading environments. Over their operational life spans, the loading regime of structures can be so severe that wear and tear deterioration is common. Furthermore, structures located in zones of high seismic activity are vulnerable to extreme loadings resulting from earthquakes. Even though design codes ensure the global collapse of structures is avoided during earthquakes, significant structural damage can still occur. For example, during the 1994 Northridge earthquake, over \$20 billion worth of structural damage was sustained within the greater Los Angeles metropolitan region [1]. In light of these facts, facility owners (both government and private) have expressed a strong desire to instrument their structural inventories with monitoring systems. Response measurements collected during ambient and forced excitations can be analyzed for better understanding of the behavior of structural designs as well as to potentially identify occurrences of structural damage.

Currently, monitoring systems designed explicitly for civil structures make extensive use of coaxial cables to transfer measurements from embedded sensors (often accelerometers and strain gages) to centralized data servers. The centralized architectural configuration is a result of structural monitoring systems having originated from centralized data acquisition systems used within laboratory settings. While structural monitoring systems have proven to be a reliable and accurate technology, their installations are expensive. For example, recent system installations conducted by the United States Geological Survey (USGS) have cost over \$5,000 per channel with 12-channel systems costing well over \$60,000 [2]. A large fraction of the cost can be attributed to the installation of the coaxial cables. For structures situated in harsh weather environments, such as long-span bridges over water, installation costs can increase because cables must be installed within weather-proof conduits.

Academic and industrial researchers are currently exploring the adoption of information technologies, such as wireless communications and embedded computing, within structural monitoring systems. Adoption of these technologies has the potential to provide future monitoring systems with enhanced functionality at substantially reduced costs. To address the high installation costs of current tethered systems, the early work of Straser and Kiremidjian illustrated wireless communications could be a cost-effective and reliable substitute for coaxial cables [3]. Lynch *et al.* has extended their work with the design of a wireless structural monitoring system assembled from a network of intelligent wireless sensing units capable of autonomous operation [4]. A key innovation proposed by Lynch *et al.* is a sophisticated computational core that can execute on-board engineering algorithms using measurement data stored in memory; embedded microcontrollers are used as the major hardware component of the computational core design. To illustrate the utility of such a core design, a statistical pattern-recognition approach to damage detection was embedded and locally executed to successfully identify damage within a laboratory test structure [5]. With computational power tightly coupled with each sensing transducer, a decentralized computational framework arises. Some advantages associated with computational decentralization include parallel processing of measurement data, elimination of single point-of-failure vulnerabilities and opportunities for large-scale installations.

A wireless structural monitoring system with on-board computational power is well suited to potentially be used as a structural health monitoring system. Structural health monitoring systems autonomously collect structural response data and process the data to identify the occurrence and location of structural damage. In order for future structural health monitoring systems to be attractive for industry adoption, damage detection algorithms embedded must be accurate and reliable. A large number of researchers have illustrated the successes and failures of different damage detection algorithms when applied to a broad class of structural systems [6]. Due to normal environmental and operational variability, many of the proposed damage detection methods have been difficult to apply to civil structures. For example, damage detection methods that consider changes in global modal properties are hindered by modal properties also exhibiting sensitivity to temperature [7]. In response to these limitations, a multi-tiered time-series approach that uses pattern classification techniques to identify structural damage has been proposed. The time-series approach has been successfully applied to various laboratory and field structures including the hull of a fast patrol boat performing within a changing operational environment [8].

The focus of this study is to extend the capabilities of a wireless sensing unit design to include an interface to which actuators can be attached. Termed a wireless active sensing unit, the monitoring system can now command actuators to excite or control a structural system. No longer solely passive elements responsible for data collection, the proposed wireless active sensing unit can have an active influence on the structural system at both a global and local level. For example, wireless active sensing units can be used for global structural control with units collecting data from sensors, calculating actuation forces and then commanding semi-active variable dampers. In this study, the actuation interface will serve as a mechanism for exciting individual structural elements with low-energy surface waves. Using piezoelectric pads mounted to the surface of structural elements, Lamb waves can be simultaneously transmitted and received by a single wireless active sensing unit. In contrast to global damage-detection procedures, the controllable low-energy excitation provided by piezoelectric pads can be used to perform damage detection at the local element level. For example, changes in Lamb wave properties correlated to damage can be detected using processing algorithms embedded in the unit core. An additional advantage associated with locally actuated excitations is that they are completely repeatable unlike ambient and seismic excitations.

In this paper, the design of a wireless active sensing unit for potential use in a structural health monitoring system is presented. To validate the performance of the proposed design, an aluminum plate with two piezoelectric elements epoxy mounted to its surface will be used. The wireless unit will command one piezoelectric pad to emit white noise surface waves while the sensing interface simultaneously records attenuated waves as received at the second pad. To illustrate the use of the computational core's ability to interrogate response data, the wireless sensing unit will locally execute numerical algorithms that calculate the transfer function and autoregressive exogenous input (ARX) time-series model of the structural element.

DESIGN OF A WIRELESS ACTIVE SENSING UNIT

The wireless active sensing unit is intended to 1) collect measurement data from sensors embedded within structural elements that are excited by low-energy actuation elements, 2) store, manage and locally process the measurement data collected, and 3) to communicate data and results to a wireless sensing network comprised of other wireless sensing/actuation agents. To accomplish the specified operational tasks, the design of the wireless active sensing unit is divided into four functional subsystems as shown in Figure 1: the sensor interface, actuation interface, computational core, and wireless communication channel.

The design procedure of each of the four subsystems will emphasize use of off-the-shelf components that satisfy the unique performance requirements of the unit. The sensing and actuation interfaces will be designed as actuator- and sensor-transparent, meaning any analog sensor or actuator, including piezoelectric elements, can be easily integrated with the system. However, the high-frequency operational regimes of piezoelectric elements will require data acquisition and control interfaces with quick real-time responses, well above 1 kHz. The performance goals of the sensing and actuation interfaces represent a significant challenge of the proposed unit design; as such, other design issues such as power consumption characteristics will not be considered in this study.

At the center of the wireless active sensing unit design is the computational core. Similar to previously proposed wireless sensing unit designs, the 32-bit Motorola MPC555 PowerPC microcontroller is selected as the core's primary hardware component. Selection of the MPC555 was motivated by its high-speed clock frequency (40 MHz) and its sophisticated internal arithmetic and logic unit with on-chip floating point calculations. High processor speeds are necessary to operate the high-frequency piezoelectric elements to be connected to the unit sensing and actuation interfaces. Internally integrated with this fast processor is 448 Kbytes of read only memory (ROM) where firmware will be stored for unit operation and embedded data processing. Since only 26 Kbytes of internal random access memory (RAM) is included in the MPC555, 512 Kbytes of external static RAM (SRAM) is added to the unit design for data storage. The read and write operations to the external memory take two clock cycles to complete and are slower than those to internal memory that take one cycle. Therefore, for applications demanding high-sample rates, data collected from the sensing interface will be written first to internal memory. After the data has been collected and real-time constraints no longer in effect, the measurement data will be transferred automatically from internal to external memory.

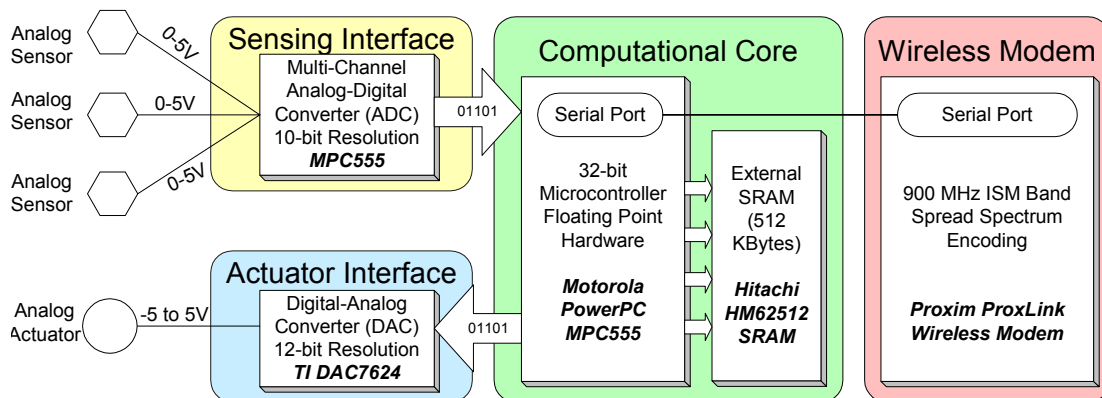

Figure 1 – Architectural design of the proposed wireless active sensing unit

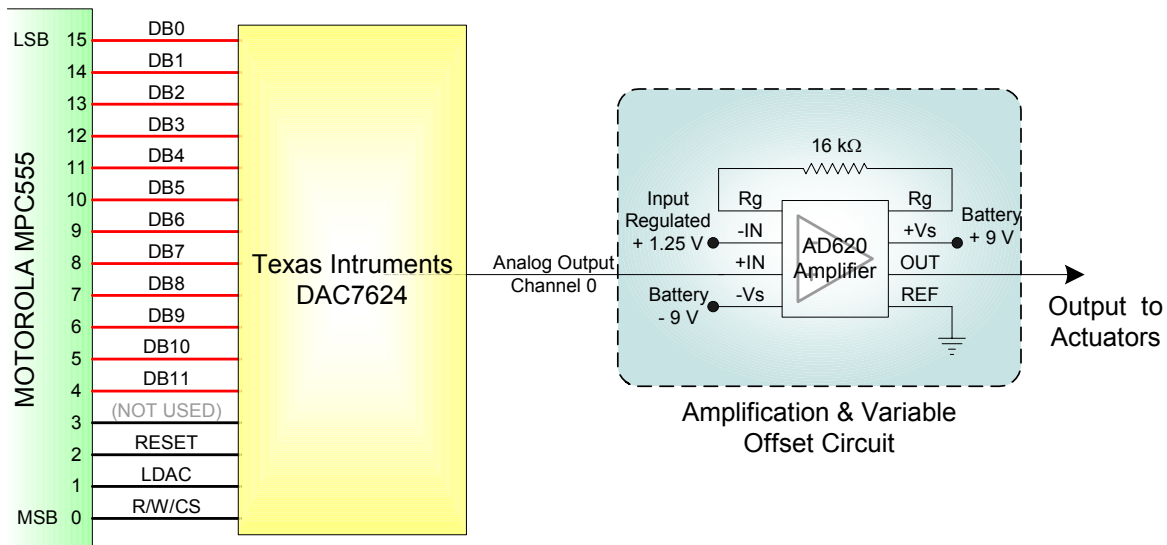

Figure 2 – Design of the general-purpose actuation interface

The on-chip 10-bit analog-to-digital converter (ADC) native to the MPC555 will be used as the sole sensing interface of the wireless active sensing unit. The sensing interface can accommodate 32 simultaneous sensing channels with sample rates as high 100 kHz. Due to the real-time demands of the data acquisition tasks, the MPC555 interrupt services are employed to read data from the interface on a strict timing schedule. Inherent latencies in servicing the interrupt service firmware limit the ADC to a maximum sample rate of 40 kHz.

The actuation interface is designed to output a range of command signals that could be used to control a large number of different structural actuators. At the core of the actuation interface is a digital-to-analog converter (DAC) that converts digital command signals generated by the MPC555 into analog representations acceptable for commanding actuators; the Texas Instruments DAC7624 is selected for this task. The DAC7624 accepts 12-bit digital samples in parallel and outputs a zero-order-hold (ZOH) analog signal from 0 to 2.5 V on four selectable channels. To attain the minimum settling time, only one channel of the quad-DAC is utilized in this study. The settling time associated with each conversion is 10 μ sec allowing digital data streams of up to 100 kHz. After the DAC makes a conversion, the output signal of the DAC is feed to an instrumentation amplifier where, the signal is range shifted and amplified. An Analog Devices AD620 amplifier is chosen to shift the DAC output to a zero mean (from 1.25 V) and amplified by 4. This will result in an actuation interface capable of outputting command voltages from -5 to +5 V using a 12-bit digital command signal issued by the MPC555. The completed hardware design of the actuation interface is presented in Figure 2. After the actuation interface is constructed in hardware, embedded firmware is written for the MPC555 to operate the interface with precise timing. Similar to the sensing interface, for each command issued to the interface, the MPC555 requires time to execute embedded firmware resulting in some time delay; as a result, the DAC is effectively limited to a 40 kHz sample rate.

A wireless communication technology that is reliable and can propagate large distances through civil structures is sought. For the wireless active sensing unit design, the Proxim ProxLink wireless modem is chosen. Operating on the 902-928 MHz unregulated FCC radio band, this modem can communicate up to 300 m in open space and 150 m within civil structures constructed of heavy material such as concrete. The radio employs frequency hopping spread spectrum techniques and performs error-checking on all received wireless packets to provide a highly reliable wireless transmission channel. One inherent drawback of wireless modems are their power consumption characteristics. When transmitting and receiving, the ProxLink modem draws 150 mA of current at 5 V. Having identified the high power demands of wireless communication gear as the primary cause of battery depletion, Lynch *et al.* have advocated the use of embedded microcontrollers to screen and consolidate information as a means of minimizing the use of the wireless medium [5]. Their work has shown that local data processing leads to reductions in the energy consumed from portable power sources thereby extending the life expectancy of autonomous wireless sensors.

ALUMINUM PLATE EXPERIMENTAL SETUP

The piezoelectricity phenomena is found in materials that have the ability to generate an internal electric potential when mechanically stressed and to undergo strain deformations when an external electric field is applied. Piezoelectric materials are both naturally occurring and laboratory manufactured with lead-zirconate-titanate (PZT) the most common synthetic piezoelectric material. The symmetric strain-electric potential property of piezoelectric materials has led to their use in a number of smart structure applications. Piezoelectrics have been widely used as strain sensors to measure high-frequency strain loads [9]. Similarly, the material has been exploited as an actuator with piezoelectric pads used to apply controllable surface forces to structural members [10]. Recently, researchers have explored the simultaneous use of piezoelectric materials as both sensor and actuator in order to measure their electro-mechanical impedance when mounted to structural elements [11].

To validate the performance of the proposed wireless active sensing unit, piezoelectric pads are selected to actuate a structural element with low-energy surface waves. Piezoelectric actuators are selected because their high-frequency operational spectrum can uniquely illustrate the performance of the unit in high-speed sample rate applications. In this study, lead-zirconate-titanate (PZT) piezoelectric pads purchased from Piezo Systems, Inc. will be employed. A 0.191 mm thick PZT sheet (T105-A4E-602) is cut to obtain small pads approximately 1.43 cm by 1.43 cm in area. The PZT sheet has been nickel plated on both sides making soldering of electrical connections easy. An electrical field will be generated between the two surfaces of the sheet parallel to the 3rd-orthogonal direction. The electrical-mechanical properties of the T105-A4E-602 piezoelectric sheet are summarized in Table 1 [12].

An aluminum plate is chosen to serve as a sample structural element to which the 1.43 cm square piezoelectric pads will be mounted. The plate is 0.3175 cm thick and has an area approximately 6.8 cm by 28.6 cm in size. As shown in Figure 3, the piezoelectric pads are epoxy mounted to the top surface of the plate 18.9 cm apart from each other. One pad is designated as the transmitting pad which will be attached to the actuation interface of the wireless active sensing unit. The second pad is designated as the receiver and is connected to the unit's sensing interface. The wireless active sensing unit will command the transmitting pad through the actuation interface with a variety of input signals. As the unit commands the transmitting pad, the unit will simultaneously collect response data from the receiving pad and record the response in the MPC555's on-chip RAM memory bank. After data has been collected, embedded engineering analyses can be locally executed using the input-output measurement data.

PERFORMANCE VALIDATION – DATA ACQUISITION AND INTERROGATION

A system identification study of the piezoelectric pad-aluminum plate system will be undertaken to fully illustrate the functionality of the proposed wireless active sensing unit design. In the study, the wireless active sensing unit will be responsible for commanding the transmitting piezoelectric pad, collecting data from the receiving pad, and locally analyzing the data to identify the system transfer function. Assuming the system is linear time invariant (LTI), the discrete transfer function of the system, $H(z)$, will be determined by the wireless sensing unit. A variety of input signals can be used to excite the dynamic system, but stationary stochastic white noise input signals with zero mean are selected. White noise inputs are convenient for system identification studies because they excite the system with equal energy across the full frequency spectrum. As a result, when the colored noise output of the dynamic system is transferred to the frequency domain, it represents the characterizing system transfer function.

Table 1 – PZT mechanical and electrical material properties

Piezoelectric Property	Value
Piezoelectric coefficient, d_{33}	390×10^{-12} m/V
d_{31}, d_{32}	-190×10^{-12} m/V
Density	7.8×10^6 g/m ³
Young modulus, E_3	5.2×10^{10} N/m ²
E_1	6.6×10^{10} N/m ²
Poisson ratio	0.31
Thermal expansion coefficient	4×10^{-6} /°C

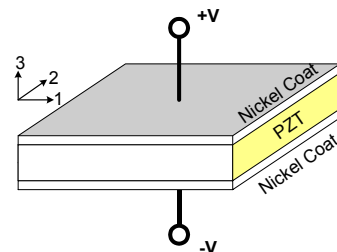

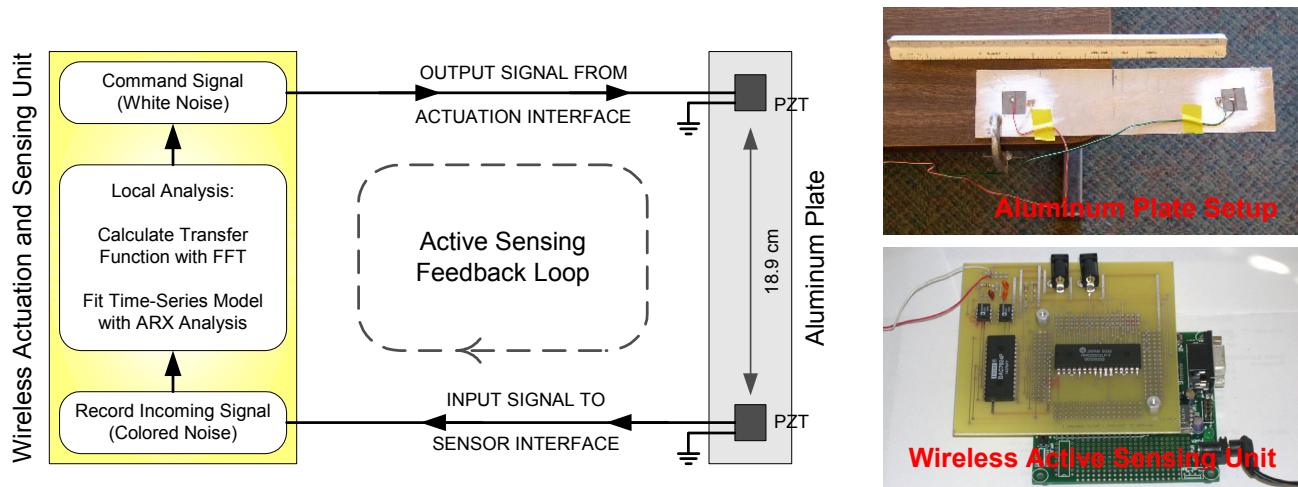

Figure 3 – Validation experiment using the piezoelectric pad-aluminum plate system

To determine a transfer function of the piezoelectric pad-aluminum plate system that captures high frequency dynamics, the actuation and sensing interfaces will both be driven at their maximum sample rates of 40 kHz. At these high-sample rates, only internal memory can be used to store both the input and output time-history records. With only 26 Kbytes of RAM memory available on the MPC555, the amount of data that can be stored during a single validation test is limited. At 40 kHz, it is determined that approximately 8,500 data points can be comfortably stored during testing.

Ten white noise signals with standard deviations varying from 0.3 V to 1.2 V in 0.1 V increments are used for system excitation. With the actuation interface limited to an output signal of ± 5 V, the white noise signals are cropped to ensure none of their samples exceed the output range. Figure 4 presents the 1.0 V standard deviation white noise input signal and the corresponding system response recorded from the receiving piezoelectric pad. As the Lamb wave propagates across the surface of the aluminum element, the signal attenuates as seen by the reduced standard deviation of 0.4 V corresponding to the output signal. The input-output time-history plots corresponding to the other white noise excitation records are similar to those presented in Figure 4.

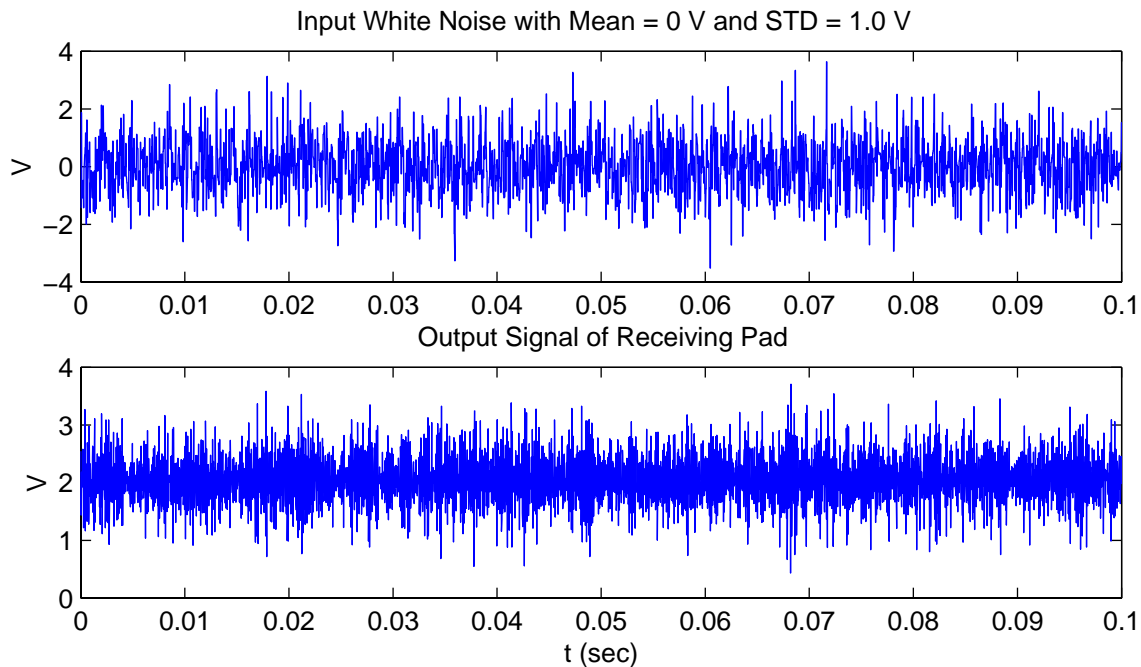

Figure 4 – White noise excitation and response of the aluminum plate (40 kHz sampling rate)

After the excitation tests on the aluminum plate have been completed, the computational core of the wireless active sensing unit takes control of the data for post-processing. The computational core is responsible for determining an input-output transfer function, $H(z)$, of the complete system. To identify the system transfer function, an autoregressive with exogenous inputs (ARX) time-series model will be calculated using the input-output time-history records. Defining the input to the system at the discrete time-step k by the variable $u(k)$, and the output, $y(k)$, an ARX time-series model can be written:

$$y(k) = \sum_{i=1}^a \alpha_i y(k-i) + \sum_{j=0}^b \beta_j u(k-j) + r(k) \quad (1)$$

The ARX model weighs past input, $u(k-j)$, and output, $y(k-i)$, measurements with coefficients β_j and α_i respectively, to predict the current output measurement, $y(k)$. The residual error associated with the prediction is denoted as $r(k)$. With Equation (1) holding for all observations of $y(k)$ from $k = a$ to N , a matrix representation of the ARX model over all time samples can easily be written:

$$\begin{bmatrix} y(a+1) \\ y(a+2) \\ \vdots \\ y(N) \end{bmatrix} = \begin{bmatrix} y(a) & y(a-1) & \cdots & y(1) & u(a+1) & u(a) & \cdots & u(a-b+1) \\ y(a+1) & y(a) & \cdots & y(2) & u(a+2) & u(a) & \cdots & u(a-b+2) \\ \vdots & \vdots & \ddots & \vdots & \vdots & \vdots & \ddots & \vdots \\ y(N-1) & y(N-2) & \cdots & y(N-a) & u(N) & u(N-1) & \cdots & u(N-b) \end{bmatrix} \begin{Bmatrix} \alpha_1 \\ \vdots \\ \alpha_a \\ \beta_0 \\ \vdots \\ \beta_b \end{Bmatrix} \quad (2)$$

$$y = Ac$$

Assuming the matrix of past input-output measurements, A , is over-determined and of full rank, least-squares data fitting can be used to determine the coefficients vector, c , of the ARX time-series model.

$$c = (A^T A)^{-1} A^T y \quad (3)$$

The wireless active sensing unit assembles the input-output response measurements into the observation matrix, A , and executes Equation (3) to determine the ARX coefficients. For example, using the data presented in Figure 4, an ARX model of order $a = 7$ and $b = 2$ is calculated by the computational core:

$$c^T = \{-0.046 \quad -1.035 \quad -0.093 \quad -0.440 \quad -0.319 \quad -0.094 \quad -0.186 \quad 0.0003 \quad 0.0022\} \quad (4)$$

The coefficients of Equation (4) are then used to determine the transfer function, $H(z)$, of the piezoelectric pad-aluminum plate system:

$$H(z) = \frac{0.0003 + 0.0022z^{-1}}{1 + 0.046z^{-1} + 1.035z^{-2} + 0.093z^{-3} + 0.440z^{-4} + 0.319z^{-5} + 0.094z^{-6} + 0.186z^{-7}} \quad (5)$$

Figure 5 presents the predicted output response of the ARX model to the white noise input with a standard deviation of 1.0 V. The predicted response is superimposed with the true response to illustrate the magnitude of the model residual error. As shown, the ARX model calculated closely predicts the output response of the piezoelectric pad-aluminum system when excited by a white noise excitation with standard deviation of 1.0 V.

CONCLUSIONS

To reduce installation costs and enhance functionality, innovative technologies are currently being adopted in structural monitoring systems. The early work of Straser and Kiremidjian, and more recently, Lynch et al., has illustrated the advantages of using wireless communications and embedded microcontrollers within a structural monitoring system [3, 4, 5]. This study has explored an extension of their work by including an actuation interface in a wireless sensing unit design. Capable of commanding structural actuators, the resulting wireless active

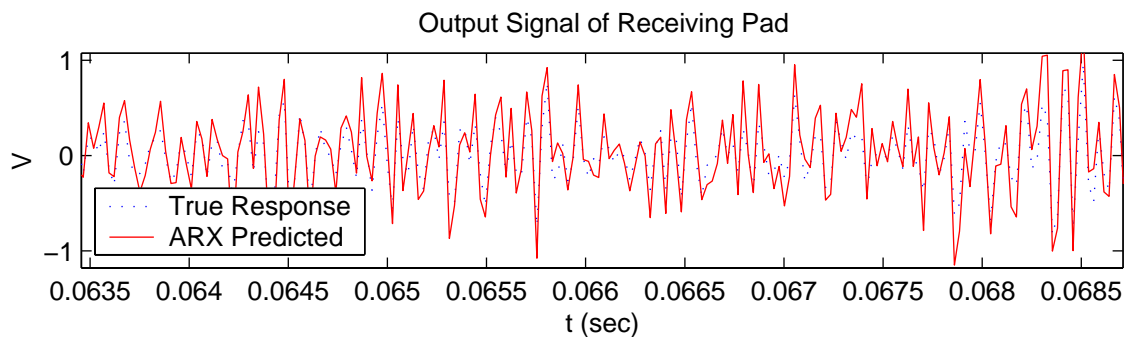

Figure 5 - Predicted and true output response to white noise excitation with 1.0 V standard deviation

sensing unit can enjoy a direct interface to the physical system in which it is installed. The proposed wireless active sensing unit is capable of recording response measurements resulting from the unit's own action. Hence, the sensor is no longer passive and is defined as an active sensor. To illustrate the performance of the prototype wireless active sensing unit, an aluminum plate with two PZT piezoelectric pads epoxy mounted to its surface is employed. With white noise excitations generated on one pad, the unit simultaneously records the response of the second piezoelectric pad. After collection of the system response, the computational core is utilized to calculate an ARX time-series model for the input-output measurement data. As illustrated in this paper, the ARX model determined by the computational core is sufficiently accurate to provide good prediction of the true output response.

Future work will seek to apply the wireless active sensing unit technology to detect damage in structural elements. Various damage detection algorithms will be embedded for local execution using input-output measurement data collected from piezoelectric elements mounted to element surfaces. With some element modal frequencies above 20 kHz sensitive to damage, improvements in the design of the wireless active sensing unit are also sought. For example, to achieve better resolution in the frequency domain, improvements in the actuation and sensing interfaces resulting in higher sample rates is needed.

ACKNOWLEDGEMENT

This research is partially sponsored by Los Alamos National Laboratory, Contract Number 75067-001-03. Additional support has been provided from the National Science Foundation, Grant Numbers CMS-9988909 and CMS-0121842.

REFERENCES

- [1] Celebi, M., Page, R. A., and Safak, E., *Monitoring earthquake shaking in buildings to reduce loss of life and property*. Fact Sheet 068-03, United States Geological Survey (USGS), Menlo Park, CA (2003).
- [2] Celebi, M., *Seismic instrumentation of buildings (with emphasis on federal buildings)*. Report No. 0-7460-68170, United States Geological Survey (USGS), Menlo Park, CA (2002).
- [3] Straser, E. G., and Kiremidjian, A. S., *A modular, wireless damage monitoring system for structures*. Report No. 128, John A. Blume Earthquake Engineering Center, Department of Civil and Environmental Engineering, Stanford University, Stanford, CA (1998).
- [4] Lynch, J. P., Sundararajan, A., Law, K. H., Kiremidjian, A. S., Kenny, T. W. and Carryer, E., "Embedment of structural monitoring algorithms in a wireless sensing unit." *Structural Engineering and Mechanics*, Vol. 15, No. 3, pp. 285-297, (2002).
- [5] Lynch, J. P., Sundararajan, A., Law, K. H., Kiremidjian, A. S., and Carryer, E., "Embedding damage detection algorithms in a wireless sensing unit for attainment of operational power efficiency." *Smart Materials and Structures*, in press, (2003).

- [6] Doebling, S. W., Farrar, C. R., Prime, M. B., and Shevitz, D. W., *Damage identification and health monitoring of structural and mechanical systems from changes in their vibration characteristics: a literature review*. Report No. LA-13070-MS, Los Alamos National Laboratory, Los Alamos, NM (1996).
- [7] Sohn, H., Worden, K., and Farrar, C., "Statistical damage classification under changing environmental and operational conditions." *Journal of Intelligent Material Systems and Structures*. Vol 13, No. 9, pp. 561-574 (2002).
- [8] Sohn, H., and Farrar, C. R., "Damage diagnosis using time series analysis of vibration signals." *Smart Materials and Structures*, Vol. 10, No. 3, pp. 446-451 (2001).
- [9] Sirohi, J., and Chopra, I., "Fundamental understanding of piezoelectrics strain sensors." *Journal of Intelligent Material Systems and Structures*, Vol. 11, No. 4, pp. 246-257 (2000).
- [10] Sun, D., and Tong, L., "Control stability analysis of smart beams with debonded piezoelectric actuator layer." *AIAA Journal*, Vol. 40, No. 9, pp. 1852-1859 (2002).
- [11] Park, G., Cudney, H. H., and Inman, D. J., "Impedance-based health monitoring of civil structural components." *Journal of Infrastructure Systems*, Vol. 6, No. 4, pp 152-160 (2000).
- [12] Piezo Systems. *Introduction to piezo transducers*. Piezo Systems, Inc., Cambridge, MA (2003).