

AN INTERNET-ENABLED SOFTWARE FRAMEWORK
FOR THE COLLABORATIVE DEVELOPMENT
OF A STRUCTURAL ANALYSIS PROGRAM

A DISSERTATION SUBMITTED TO
THE DEPARTMENT OF CIVIL AND ENVIRONMENTAL ENGINEERING
AND THE COMMITTEE ON GRADUATE STUDIES
OF STANFORD UNIVERSITY
IN PARTIAL FULFILLMENT OF THE REQUIREMENTS
FOR THE DEGREE OF
DOCTOR OF PHILOSOPHY

Jun Peng

October 2002

© Copyright by Jun Peng 2002

All Rights Reserved

I certify that I have read this dissertation and that, in my opinion, it is fully adequate in scope and quality as a dissertation for the degree of Doctor of Philosophy.

Kincho H. Law
(Principal Advisor)

I certify that I have read this dissertation and that, in my opinion, it is fully adequate in scope and quality as a dissertation for the degree of Doctor of Philosophy.

Gregory G. Deierlein

I certify that I have read this dissertation and that, in my opinion, it is fully adequate in scope and quality as a dissertation for the degree of Doctor of Philosophy.

Eduardo Miranda

I certify that I have read this dissertation and that, in my opinion, it is fully adequate in scope and quality as a dissertation for the degree of Doctor of Philosophy.

Frank T. McKenna

Approved for the University Committee on Graduate Studies:

Abstract

This thesis describes the research and prototype implementation of an Internet-enabled software framework that facilitates the utilization and the collaborative development of a finite element structural analysis program by taking advantage of object-oriented modeling, distributed computing, database and other advanced computing technologies. This new framework allows users easy access to the analysis program and the analysis results by using a web-browser or other application programs, such as MATLAB. In addition, the framework serves as a common finite element analysis platform for which researchers and software developers can build, test, and incorporate new developments.

The collaborative software framework is built upon an object-oriented finite element program. The research objective is to enhance and improve the capability and performance of the finite element program by seamlessly integrating legacy code and new developments. Developments can be incorporated by directly integrating with the core as a local module and/or by implementing as a remote service module. There are several approaches to incorporate software modules locally, such as defining new subclasses, building interfaces and wrappers, or developing a reverse communication mechanism. The distributed and collaborative architecture also allows a software component to be incorporated as a service in a dynamic and distributed manner. Two forms of remote element services, namely the distributed element service and the dynamic shared library element service, are introduced in the framework to facilitate the distributed usage and the collaborative development of a finite element program.

The collaborative finite element software framework also includes data and project management functionalities. A database system is employed to store selected analysis results and to provide flexible data management and data access. The Internet is utilized as a data delivery vehicle and a data query language is developed to provide an easy-to-use mechanism to access the needed analysis results from readily accessible sources in a ready-to-use format for further manipulation. Finally, a simple project management scheme is developed to allow the users to manage and to collaborate on the analysis of a structure.

Acknowledgments

There have been a great number of truly exceptional people who contributed to my research and social life at Stanford University.

First and foremost, I wish to express my profound gratitude to Prof. Kincho H. Law, my advisor and mentor, for his continuous commitment, encouragement, and support. I feel privileged for having had the opportunity to share his passion for research and his insights in life. I would like to extend my gratitude to my dissertation committee, Prof. Gregory G. Deierlein, Prof. Eduardo Miranda, and Dr. Frank McKenna, for their advice, criticism, and recommendations. I also want to thank Prof. Michael A. Saunders for chairing my oral defense on such short notice.

Many other people contributed to the development of this research. I would like to thank Dr. Frank McKenna and Prof. Gregory L. Fenves of UC, Berkeley for their collaboration and support of this research. They provided me not only the source code of OpenSees but also continuous support throughout my research. Thanks to Dr. David Mackay for providing the source code of the linear sparse solver SymSparse and the suggestions on how to use the solver, and to Mr. Yang Wang for the implementation of a Lanczos solver for generalized eigenvalue problem. Thanks also to Mr. Ricardo Medina at Stanford University who provided me the eighteen story one-bay frame analysis model. I am also grateful to Dr. Zhaohui Yang, Mr. Yuyi Zhang, Prof. Ahmed Elgamal, and Prof. Joel

Conte at University of California, San Diego for providing the Humboldt Bay Middle Channel Bridge model and valuable suggestions.

I am grateful to the members of the EIG (Engineering Informatics Group), including Jerome Lynch, David Liu, Jie Wang, Chuck Han, Hoon Sohn, Shawn Kerrigan, Gloria Lau, Jim Cheng, Charles Heenan, Li Zhang, Liang Zhou, Bill Labiosa, Yang Wang, Arvind Sundararajan, and Pooja Trivedi, for helping me with various aspects of my research and life. They make the research group truly like a home to me.

Finally, I would like to thank my family. Their love and support from the distance have sustained me and enabled my every accomplishment over the years.

This research was supported in part by the Pacific Earthquake Engineering Research Center through the Earthquake Engineering Research Centers Program of the National Science Foundation under Award number EEC-9701568, and in part by NSF Grant Number CMS-0084530. The Technology for Education 2000 equipment grant from Intel Corporation provides the computers employed in this research.

Table of Contents

Abstract	iv
Acknowledgments	vi
List of Tables	xii
List of Figures	xiii
1 Introduction	1
1.1 Problem Statement	1
1.2 Related Research.....	3
1.2.1 Object-Oriented Finite Element Programs	3
1.2.2 Distributed Object Computing	6
1.2.3 Data Management in FEA Computing.....	8
1.3 Thesis Outline	11
2 Object-Oriented Finite Element Program and Module Integration	14
2.1 Fundamental Features of Object-Oriented Finite Element Programs	16
2.1.1 Object-Oriented Programming	16
2.1.2 Design and Implementation of Object-Oriented FEA Programs	19
2.1.3 OpenSees	21
2.2 Direct Module Integration.....	26
2.2.1 Incorporating New Developments.....	27
2.2.2 Linking Software Components.....	29
2.2.2.1 Graph Representation of Matrices.....	31

2.2.2.2	Linking METIS Routines	32
2.2.3	Integration of Legacy Applications	34
2.2.3.1	Procedures of SymSparse Direct Solver	35
2.2.3.2	Integration of SymSparse Direct Solver.....	38
2.3	Model Integration with Reverse Communication Interface.....	40
2.3.1	Reverse Communication Interface	41
2.3.2	Incorporating Eigensolvers with OpenSees.....	42
2.4	Quality and Performance Measurements	45
2.4.1	Comparison of Matrix Ordering Schemes.....	47
2.4.2	Performance Comparison of Linear Solvers	49
2.4.3	Comparison of Eigensolvers.....	52
2.5	Summary	54
3	Open Collaborative Software Framework	56
3.1	Overview of the Collaborative Framework	58
3.1.1	System Architecture	58
3.1.2	Mechanics.....	61
3.1.3	Modular Design	62
3.2	User Interfaces	64
3.2.1	OpenSees Tcl Input Interface	65
3.2.2	Web-Based User Interface.....	69
3.2.2.1	Web-to-OpenSees Interaction	69
3.2.2.2	Servlet Server-to-OpenSees Interaction	71
3.2.3	MATLAB-Based User Interface	73
3.2.3.1	Network Communication	74
3.2.3.2	Data Processing.....	75
3.3	Example	78
3.3.1	Sample Web-Based Interface	80
3.3.2	Sample MATLAB-Based Interface	82
3.4	Summary	83

4	Internet-Enabled Service Integration and Communication	85
4.1	Registration And Naming Service	88
4.2	Distributed Element Services.....	91
4.2.1	Mechanics.....	92
4.2.2	Interaction with Distributed Services	98
4.2.3	Implementation.....	101
4.3	Dynamic Shared Library Element Services.....	104
4.3.1	Static Library vs. Shared Library	104
4.3.2	Mechanics.....	106
4.3.3	Implementation.....	107
4.4	Application.....	111
4.4.1	Example Test Case	111
4.4.2	Performance of Online Element Services.....	115
4.5	Summary and Discussion.....	117
5	Data Access and Project Management	119
5.1	Multi-Tiered Architecture	121
5.2	Data Storage Scheme	125
5.2.1	Selective Data Storage.....	126
5.2.2	Object Serialization	129
5.2.3	Sampling at a Specified Interval.....	133
5.3	Data Representation	136
5.3.1	Data Modeling.....	136
5.3.2	Project-Based Data Storage	138
5.3.3	Data Representation in XML.....	140
5.4	Data Query Processing.....	144
5.4.1	Data Query Language.....	145
5.4.2	Data Query Interfaces.....	148
5.5	Applications	150
5.5.1	Example 1: Eighteen Story One Bay Frame Model	151

5.5.2 Example 2: Humboldt Bay Middle Channel Bridge Model.....	154
5.5.2.1 Project Management.....	156
5.5.2.2 Data Storage and Data Access.....	158
5.6 Summary and Discussion.....	162
6 Summary and Future Directions	164
6.1 Summary	165
6.2 Future Directions.....	167
Bibliography	170

List of Tables

<i>Number</i>	<i>Page</i>
Table 2.1: Number of Nonzero Entries in the Matrix for Different Ordering Schemes	48
Table 2.2: Solution Time (in Seconds) for Different Linear Solvers	50
Table 2.3: The Eigenvalues and Their Precisions for Different Eigensolvers.....	53
Table 2.4: Performance Comparison Between Lanczos Solver and ARPACK Solver	53
Table 4.1: The Comparison Between Local and Remote Java Objects	94
Table 4.2: The Comparison Between Static and Shared Libraries	105
Table 4.3: The Performance of Using Different Element Services	115
Table 5.1: Solution Time (in Minutes) for Nonlinear Dynamic Analysis	159
Table 5.2: Solution Time (in Minutes) for Re-Computation	159

List of Figures

<i>Number</i>	<i>Page</i>
Figure 2.1: Class Abstraction in OpenSees (from [76])	24
Figure 2.2: Class Diagram for OpenSees Analysis Framework (from [76])	25
Figure 2.3: Pseudo-Code for getTangentStiff Method of QuadEightElement Class.....	29
Figure 2.4: An Example of the CSR Storage for Matrix Structure.....	32
Figure 2.5: Class Interface for the MetisPartitioner Class.....	33
Figure 2.6: Pseudo-Code for partition Method of MetisPartitioner Class.....	33
Figure 2.7: Pseudo-Code for Incorporating METIS_NodeND Method	35
Figure 2.8: Interface for the SymSparseLinSOE Class	39
Figure 2.9: The Control Flow of Integrating the SymSparse Linear Solver.....	40
Figure 2.10: Class Diagram for Eigenvalue Analysis in OpenSees.....	43
Figure 2.11: Linking ARPACK Through Reverse Communication Interface	46
Figure 2.12: Quality Comparison of Different Matrix Ordering Schemes.....	48
Figure 2.13: Performance Comparison for Different Linear Solvers	50
Figure 3.1: The Collaborative System Architecture	60
Figure 3.2: The Mechanics of the Collaborative Framework.....	61
Figure 3.3: The Modules of the Collaborative System.....	64
Figure 3.4: The Three-Truss Example (from [77]).....	67
Figure 3.5: The Interaction Diagram for the Web-Based Interface	71
Figure 3.6: The Interaction Diagram for the MATLAB-Based Interface.....	75

Figure 3.7: Array Representations in Java and MATLAB (from [115])	77
Figure 3.8: The Example Model and the Northridge Earthquake Record	78
Figure 3.9: Part of the Tcl Input File for the Example Model	79
Figure 3.10: Sample Web Pages Generated on the Client Site.....	81
Figure 3.11: Sample MATLAB-Based User Interface	83
Figure 4.1: Registering and Resolving Names In RANS	89
Figure 4.2: The Schema of the ServiceInfo Table	89
Figure 4.3: Interface for the RANS Class.....	90
Figure 4.4: The Purpose of JNI (from [112]).....	97
Figure 4.5: The Mechanics of the Distributed Element Service.....	97
Figure 4.6: Interface for the ElementRemote Class.....	100
Figure 4.7: Interaction Diagram of Distributed Element Service	101
Figure 4.8: Sample ElementClient and Sample ElementServer	102
Figure 4.9: The Mechanics of Dynamic Shared Library Element Service.....	106
Figure 4.10: The Binding of a Dynamic Shared Library	110
Figure 4.11: Web Interface for Registration and Naming Service	113
Figure 4.12: Interaction of Distributed Services.....	114
Figure 4.13: Graphical Response Time History of Node 1	114
Figure 5.1: Online Data Access System Architecture	122
Figure 5.2: Class Diagram for FE_Datastore.....	124
Figure 5.3: Interface for the DB_Datastore Class.....	125
Figure 5.4: Interface for MovableObject Class.....	131
Figure 5.5: Pseudo Code for recvSelf Method of the Domain Class.....	132
Figure 5.6: Pseudo Code for Converting the Domain State.....	135
Figure 5.7: Database Schema Diagram for the Online Data Access System.....	139
Figure 5.8: The Relation of XML Services	142
Figure 5.9: XML Representation of Matrix-Type Data.....	143
Figure 5.10: XML Representation of Packaged Data.....	144
Figure 5.11: Interaction Diagram of Online Data Access System.....	149

Figure 5.12: The Displacement Time History Response of Node 1	153
Figure 5.13: Humboldt Bay Middle Channel Bridge (Courtesy of Caltran)	155
Figure 5.14: Finite Element Model for Humboldt Bay Bridge (from [19]).....	156
Figure 5.15: The List of Current Humboldt Bay Bridge Projects.....	157
Figure 5.16: 1994 Northridge Earthquake Recorded at the Rinaldi Station.....	157
Figure 5.17: Deformed Mesh of Humboldt Bay Bridge Model (from [19])	158
Figure 5.18: Web Pages of the Response Time Histories.....	161
Figure 5.19: Sample MATLAB-Based User Interface	161

Chapter 1

Introduction

1.1 Problem Statement

It is well recognized that a significant gap exists between the advances in computing technologies and the state-of-practice in structural engineering software development. Practicing engineers today typically perform finite element structural analyses on a dedicated computer using the developments offered by a single finite element analysis program. Typically, a finite element software package is developed by an individual organization and bundles all the procedures and program kernels.

As technologies and structural theories continue to advance, structural analysis software packages need to be able to accommodate new developments in element formulation, material relations, analysis algorithms, solution strategies, and computing environments. The need to develop and maintain large complex software systems in a dynamic environment has driven interest in new approaches to finite element analysis software design and development. Object-oriented design principles and programming can be utilized in finite element software development to support better data encapsulation and

to facilitate code reuse. However, most existing object-oriented finite element programs remain rigidly structured. Extending and upgrading these programs to incorporate new developments and legacy applications remain to be a difficult task. Moreover, there is no easy way to access computing resources and finite element analysis services distributed in a remote site.

With the advances of computing facilities and the development of communication network in which the computing resources are connected and shared, the programming environment has migrated from relying on single and local computing environment to developing software in a distributed and global environment. With the maturation of information and communication technologies, the concept of building collaborative systems to distribute the services over the Internet is becoming a reality [46]. Following this idea, we have designed and prototyped an Internet-enabled collaborative framework for the usage and development of a finite element analysis program. The collaborative software framework is built upon an object-oriented finite element core program. The collaborative framework is designed to enhance and improve the capability and performance of the finite element program by seamlessly integrating legacy code and new developments. Developments can be incorporated by directly integrating with the core as a local module and/or by implementing as a remote service module. The Internet provides many possibilities for enhancing the distributive and collaborative software development and utilization. Using the Internet as a communication channel, which supports standard communication protocols and network transparency, the collaborative framework gives the users the ability to pick and choose the most appropriate methods and software components for solving a problem.

To support collaboration among software developers and engineering users, the finite element software framework also includes data and project management functionalities. A database system is employed to store selected analysis results and to provide flexible data management and data access. The Internet is utilized as a data delivery vehicle and a data query language is developed to provide an easy-to-use mechanism to access the

needed analysis results from readily accessible sources in a ready-to-use format for further manipulation. Finally, a simple project management scheme is developed to allow the users to manage and to collaborate on projects. Access control and revision control capabilities are integrated with the project management system.

1.2 Related Research

The Internet-enabled collaborative software framework is based on an object-oriented finite element analysis program. Distributed and collaborative computing is utilized in the framework to allow an element service to be distributed over the Internet. A database is linked with the software framework to provide persistent data storage and to facilitate data and project management. This section presents an overview of some work related to this research effort, including object-oriented finite element programs, distributed object computing, and data management in finite element programs.

1.2.1 Object-Oriented Finite Element Programs

Most existing finite element software packages are developed in procedural-based programming languages. These packages are normally monolithic and difficult for a programmer to maintain and extend, though some of them are quite rich in terms of functionality. Extensibility usually requires access to and manipulation of internal data structures. Due to the lack of data encapsulation and protection, small changes in one piece of code can ripple through the rest of the software system. For example, to add a new element to an existing procedural-based finite element analysis software package, the programmer is usually required to specify, at the element level, the memory pointers to global arrays. Exposing such unnecessary implementation details increases the software complexity and adds a burden to a programmer. Even worse, any change to these global data structures to accommodate new functionalities will require the

implementation of other elements to be changed. Therefore, such access may compromise the reliability and integrity of the system. Furthermore, these packages do not provide a set of crisply defined high-level abstraction or software components by which a programmer can construct new applications to meet new functional requirements. For example, it is very difficult to extend an existing linear static analysis program to geometric nonlinear or material nonlinear transit analysis. It is difficult for researchers to test new algorithms in an existing structural engineering software. Few existing structural analysis programs offer the test-bed capabilities for rapid prototyping due to the lack of high-level reusable components and their severe inherent limitations in maintainability and extendibility.

Object-oriented design principles and programming techniques can be utilized in finite element analysis programs to support better data encapsulation and to facilitate code reuse. A number of object-oriented finite element program design and implementations have been presented in the literature over the past decade [4, 18, 27, 30, 36, 55, 72, 73, 76, 81, 86, 97, 104, 107]. Object-oriented finite element analysis packages, particularly those written in C++, have been shown to have comparable performance to their procedural-based counterparts and still provide the maintainability and extendibility essential for modern day software packages [27, 76, 104]. The flexibility and extendibility of these packages are partly due to the object-oriented support of encapsulation, inheritance, and polymorphism. There are three essential steps in the development of object-oriented systems: identification of the classes, specification of the class interfaces, and implementation.

Much of the early work concentrated on fairly straightforward implementations of FEM in an object-oriented programming language – separate objects were created for elements, nodes, loads, materials, degree of freedoms, etc. [36, 72, 121]. Some work has been devoted to using object-oriented design to carry out complex algorithms. The technique has been applied to many application areas including stress analysis [27, 55, 65], hypersonic shock waves [11], structural dynamics [4, 97], shell structures [84], nonlinear

plastic strain [79], and electromagnetics [108]. There are algorithms that are difficult to program using procedural languages (e.g. Fortran), but became easier in object-oriented programming languages because of the richer data structures that can be created. A particularly interesting application was using objects to represent substructures [51]. The application was applied to repetitive structures, and it enabled the user to create the mesh easily by using a series of copy, translation, and reflection operations. Eyheramendy and Zimmermann [30] used objects to develop a system that enabled the underlying mathematics of finite element method to be represented.

There are several popular object-oriented programming languages such as Smalltalk, C++, and Java, etc. C++ is by far the most popular programming language for implementing object-oriented finite element analysis programs. C++ was chosen because of its availability, popularity, efficiency, and built-in libraries. One of the appealing features of C++ is that it provides object-oriented capabilities as well as C functional elements. This hybrid language feature helps to make C++ applications efficient. If implemented properly, C++ applications tend to be more efficient than pure object-oriented languages (e.g. Smalltalk, Java, etc.) and better suited to solve numerical problems arising in engineering applications. Moreover, most of the C++ compilers provide easy calls to Fortran routines. This is an important advantage, because it enables the reuse of many efficient Fortran sub-programs. Another powerful feature of C++ is the concept of dynamic binding of functions. It supports the mechanism of polymorphism and is activated by adding the keyword `virtual` in a function definition. This keyword notifies the compiler to decide during the runtime which function should be called. The dynamic binding of functions makes the programs more flexible and also facilitates code reuse. Finally, most of the C++ compilers provide an array of class libraries, which can solve many implementation details at the lower class libraries. They shift the programmer's efforts to a higher-level abstraction, focusing on the overall organization and design of the program. Typical class libraries include classes for string and input/output operations, as well as container classes for storing and managing data.

1.2.2 Distributed Object Computing

Distributed object computing extends an object-oriented programming system by allowing objects to be distributed across a heterogeneous network, so that each of these distributed object components can interoperate as a unified system. These object may be distributed on different computers throughout a network, living within their own address space outside of an application, and yet appear as though they were local to a central application. The basic extension for distributed object-oriented system is to provide remote procedure calls from a thread on one machine to an object on another machine, using the same basic syntax and semantics as a local call. A key property of distributed object computing is dispatching on the object first, rather than binding to a particular procedure. Dispatching on the object allows there to be multiple simultaneous different implementations.

Three of the most popular distributed object paradigms are Object Management Group's (OMG) Common Object Request Broker Architecture (CORBA) [90, 100], Microsoft's Distributed Component Object Model (DCOM) [28], and Sun Microsystems' Java Remote Method Invocation (RMI) [98]. The following gives a brief overview of these three distributed object computing technologies. A detailed comparison of CORBA, DCOM and Java RMI has been discussed by Raj [101].

The Common Object Request Broker Architecture (CORBA) is a source interface standard being promoted by the Object Management Group (OMG), an industry standard consortium. While the traditional objects reside in a single computer (within a single process or multiple processes), distributed objects may reside in several nodes in a network. Robust distributed objects may be written in different languages, and can be compiled by different compilers, while they communicate with each other via standardized protocols embodied by middleware [60]. Everything in the CORBA architecture depends on an Object Request Broker (ORB). The ORB acts as a central object registry where each CORBA object interacts transparently with other CORBA

objects located either locally or remotely. CORBA relies on a protocol called the Internet Inter-ORB Protocol (IIOP) for remote objects. Each CORBA server object has an interface and exposes a set of methods. To request a service, a CORBA client acquires an object reference to a CORBA server object. The client can make method calls on the object reference as if the CORBA server object resides in the client's address space. The ORB is responsible for finding the CORBA object's implementation, preparing it to receive requests, communicating request to it, and carrying the reply back to the client. A CORBA object interacts with the ORB either through the ORB interface or through an object adapter. Since CORBA is just a specification, it can be used on diverse operating system platforms as long as there is an ORB implementation for that platform. The distributed objects in the CORBA environment can be implemented in various programming languages, such as C/C++ [47] or Java [87].

The Microsoft DCOM, extended from Component Object Model (COM) and more recently in COM+, provides a distributed object framework as an extension of the OLE (Object Linking and Embedding) facility. OLE allows objects to be linked by reference between types of documents and objects to be embedded in other objects. DCOM supports remote objects by running on a protocol called the Object Remote Procedure Call (ORPC). The ORPC layer is built on top of standard remote procedure call (RPC) and interacts with COM's runtime services. A DCOM server is a body of code that is capable of serving up objects of a particular type at runtime. Each DCOM server object can support multiple interfaces each representing a different behavior of the object. A DCOM client class calls into the exposed methods of a DCOM server by acquiring a pointer to one of the server object's interfaces. The client object then starts calling the server object's exposed methods through the acquired interface pointer as if the server object resides in the client's address space. Since the COM specification is at the binary level, it allows DCOM server components to be written in diverse programming languages like C++, Java, and Visual Basic, etc. As long as a platform supports COM services, DCOM can be used on that platform. DCOM is heavily used on the Microsoft Windows platform.

Java RMI relies on a protocol called the Java Remote Method Protocol (JRMP). Java relies heavily on Java *Object Serialization*, which allows objects to be marshaled (or transmitted) as a byte stream. Since Java Object Serialization is specific to Java, both the Java RMI server object and the client object have to be written in Java. Each RMI server object defines an interface which can be used to access the server object outside of the current Java Virtual Machine (JVM) and on another machine's JVM. The interface exposes a set of methods that are indicative of the services offered by the server object. For a client to locate a server object for the first time, RMI depends on a registration and naming mechanism called an *RMIRegistry* that runs on the Server machine and holds information about available server objects. A RMI client acquires an object reference to a JRMI server object by doing a *lookup* for a server object reference and invokes methods on the server object as if the RMI server object resides in the client's address space. RMI server objects are named using Uniform Resource Locator (URLs) and for a client to acquire a server object reference, the client should specify the URL of the server object similar to the URL for a HTML page. Since RMI relies on Java, it can be used on diverse operating system platforms from mainframes to UNIX workstations to Windows machines and handheld devices, as long as there is a Java Virtual Machine (JVM) implementation for that platform.

The architectures of CORBA, DCOM and Java RMI provide mechanisms for transparent invocation and accessing of remote distributed objects. Though the mechanisms that they employ to achieve distributed computing may be different, the approach that each of them takes is more or less similar.

1.2.3 Data Management in FEA Computing

The importance of data management system in scientific and engineering computing has been recognized for over thirty years. Techniques for general data management were gradually making inroads in scientific computing during the 1970s. This development

paralleled in many ways the rapid acceptance of the centralized database concept in business-oriented processing. However, engineering data manipulation systems faced a specialized environment with its own set of operational requirements. To present the specialized environment and operational requirements of engineering data management systems, Felippa [32-34] published a series of three papers on database usage in scientific computing. These papers reviewed general features of scientific data management from a functional standpoint, including the description of a database-linked engineering analysis system, the organization of a database system, and the program operational compatibility. The general data structures and program architecture were also presented, together with the issues regarding implementation and deployment. In 1983, Blackburn et al. [7] described a relational database (RDB) management system for computer-based integrated design, including application to the analysis of various structures to demonstrate and evaluate the ability of RDB system to store, retrieve, query, modify, and manipulate data. All these papers emphasized the importance of centralized data management for large-scale computing. Two factors that determined the favor of centralized scientific data management were: the sheer growth of large-scale engineering analysis codes to the point of incipient instability as regards to propagation of local program errors, and the appearance of integrated program networks that share a common project database. Centralized data management was most effective when used in conjunction with a highly-modular, structured program architecture [33].

The role of databases as repositories of information (data) highlighted the importance of data structures. The component data elements of data structures could be either atomic (i.e. non-decomposable) or data structures themselves. The relationships between these component data elements constitute the structure and have implications for the functions of the data structure [3]. Several general approaches and models for organizing the data have been developed. They are: the hierarchical approach, the network approach, the relational approach, and the object-oriented approach. The hierarchical approach and the network approach are the traditional means of organizing data and their relationships. The relational model has been adopted in several finite element programs [7, 102, 119].

The object-oriented approach is the foundation for many object-oriented database management systems, such as EXODUS [14], which is an extensible database system to facilitate the fast development of high-performance, application-specific database systems. No matter which data model is used, data structures need to be self-describable [32]. For practical reasons we can generally exclude the naïve approach of forcing every program component to agree on a unified data structure. The next best thing is to require each program to label its output data, i.e. to attach a descriptive label to each data structure that would be saved in the database. Such tags can then be examined by the control structure of other programs and appropriate actions can be taken.

Presently, the state-of-practice for data management in finite element analysis (FEA) programs still mainly rely on file systems. To facilitate the sharing of information, loosely-coupled systems could talk to each other through the same file system. However, data placed by an application program into the file system may well not be acceptable to another program because of format incompatibility. To tackle this problem, Yang [119] defined a standard file format for the analysis data, called the universal file (UF). Two interfaces have been proposed. The first is a specified set of subroutines to transfer the input or output files of the programs into UF. The second is a set of subroutines to translate UF into the database configured to aid FEM modeling operations. Another effort to address file format compatibility is the neutral file approach introduced for integrated Computer-Aided Design (CAD) systems [82]. The neutral file approach establishes a standard file format and information structures to be used for the digital representation and communication of product definition data. Using a neutral standard for transferring information across systems drastically reduces the requirements for file format translators.

For finite element programs, the post-processing functions need to allow the recovery of analysis results and provide extensive graphical and numerical tools for gaining an understanding of results. In this sense, querying database is an important aspect and query languages need to be constructed to interrogate databases. A free-format data

query language has been designed and provided in SADDLE (Structural Analysis and Dynamic Design Language) [102]. Although the commands to create, edit, and update the data have been provided, the query language was hard for human to interpret. In order to manage engineering databases, a data query system should provide query commands that resemble natural language, as well as simple data manipulation procedures [35]. Simple natural language interface has also been attempted in querying the qualitative description of dynamic simulation data [16]. The commands of this language are easy for human to interpret. However, the drawback is that it is difficult to write a parser for the language.

1.3 Thesis Outline

The objective of this research is to develop an Internet-enabled software framework that facilitates the utilization and the collaborative development of a finite element structural analysis program by taking advantage of object-oriented modeling, distributed computing, database and other advanced computing technologies. The framework is designed to provide users and developers with easy access to an analysis platform and the selected analysis results.

The rest of this thesis is organized into the following five chapters:

- Chapter 2 reviews the features of object-oriented finite element analysis (FEA) programs and discusses their support of integrating existing software components and new developments. The main class abstractions adopted in a typical object-oriented FEA program are according to the basic steps involved in a finite element analysis. The flexibility and extendibility of an object-oriented FEA program can be exemplified with the ease of incorporating new developments and existing software modules. The software extending process normally requires one or several subclasses of the base classes to be introduced, and interfaces or wrappers to be constructed. In

- this chapter, several approaches of local module integration for an object-oriented FEA program are discussed with examples, including the incorporation of a new element, a popular graph partitioning and ordering package, a sparse linear solver, and two eigensolvers. There is one common feature for all these local module integration approaches – the changes to the existing code tend to be localized. After the software components are seamlessly integrated, the capacity and performance of the object-oriented FEA program can be greatly improved.
- Chapter 3 introduces an Internet-enabled software framework that would facilitate the utilization and the collaborative development of FEA programs. The objective of this chapter is to provide an overview of the framework, its modular design, and the interaction among the modules. A set of Internet-enabled communication protocols is defined to link external components which can be easily integrated to the collaborative framework through a *plug-and-play* environment. Two types of user interaction interfaces, namely the web-based interface and MATLAB-based interface, are presented with example usage.
 - Chapter 4 describes in detail the development of an application service and its integration with the Internet-enabled finite element analysis framework. One salient feature of the Internet-enabled collaborative software framework is to facilitate analysts to integrate new developments with the core server in a dynamic and distributed manner. A diverse group of users and developers can easily access the framework and contribute their own developments to the central core. By providing a modular infrastructure, services can be added or updated without the recompilation or reinitialization of the existing services. For illustration purpose, this chapter focuses on the model integration of new elements to the analysis core. There are two types of online element services, which are the distributed element service and the dynamic shared library element service.

- Chapter 5 presents a prototype implementation of an online data access system for the Internet-enabled collaborative software framework. The objective of using an engineering database is to provide the users the needed engineering information from readily accessible sources in a ready-to-use format for future manipulation. The main design principle of the system is to separate data access and data storage from data processing, so that each part of the system can be designed and implemented separately. In this work, a commercial database system is linked with the central finite element analysis server to provide the persistent storage of selected analysis results. By adopting a commercial database system, we can address some of the problems encountered by the prevailing file system-based data management. Since the Internet is utilized as the communication channel, the data access system would allow users to query the core server for useful analysis results, and the information retrieved from the database through the FEA core server is returned to the users in a standard format.
- Finally, Chapter 6 summarizes this work and outlines future research directions. The Internet-enabled collaborative software framework is a new paradigm for the design and implementation of finite element programs. The standard communication protocols and network transparency of the collaborative framework give users the ability to pick and choose the most appropriate methods and software components for solving a problem. Because the Internet environment is utilized in the framework, the security, performance, and fault tolerance issues need to be further explored.

Chapter 2

Object-Oriented Finite Element Program and Module Integration

Finite element analysis (FEA) programs are becoming ever more powerful, not just in terms of the problems they can solve, but also in their pre- and post-processing capabilities. These software applications are becoming more complex and more difficult to maintain. One serious concern of traditional procedural-based programming is that even a simple change, especially to the data structure, could have ripple effects throughout the code. This greatly increases the chances of errors and program bugs being introduced, and increases maintenance costs. Object-oriented principles can alleviate some of these burdens as the data are encapsulated in closed compartments (objects) and are accessed only via methods or functions. The data access is more tightly controlled, and the effects of code changes tend to be more localized.

One of the challenges in the design and implementation of an object-oriented finite element analysis program is the integration of legacy code. Finite element method has been introduced for over forty years and many sophisticated and advanced procedures have been developed. Some of these existing procedures (modules or components) can be reused in an object-oriented FEA program to enhance its analysis capabilities, improve

its performance, and save the re-development efforts. This chapter discusses various approaches to integrate these existing software components and applications into object-oriented FEA programs.

This chapter is organized as follows:

- Section 2.1 reviews the basic principles and features of existing object-oriented finite element analysis programs. OpenSees [78] is presented in this section as a particular example of object-oriented finite element analysis programs.
- Section 2.2 describes the basic procedures for integrating software components into an object-oriented FEA program. In this work, the approaches to integrate software modules are illustrated using OpenSees. Several examples are presented to illustrate the integration process, including the integration of an element, a graph partitioning and ordering package, and a sparse linear direct solver.
- Section 2.3 describes a reverse communication interface for software module integration. Reverse communication is a mechanism that avoids having to use fixed data structures through a subroutine with a fixed calling sequence, therefore the user can choose the most appropriate data structures for the program. The usage of reverse communication interface in an object-oriented FEA program is illustrated with the examples of integrating eigensolvers.
- Section 2.4 gives some qualitative and quantitative performance measurements for the incorporated software modules described in this chapter. The experimental results demonstrated that the analysis capability and performance of an object-oriented FEA program could be greatly enhanced by incorporating existing applications.

2.1 Fundamental Features of Object-Oriented Finite Element Programs

To facilitate code reuse and to provide a program that is flexible and extendible, object-oriented design principles have been proposed and applied to the implementation of finite element analysis programs. The advantages of using object-oriented programming paradigms are: (1) easier to maintain programs; (2) easier to implement complex algorithms; and (3) better integration of analyses and designs.

2.1.1 Object-Oriented Programming

Object-orientation makes it possible to model systems that are very close in structure to their real-world analogues. The objective of object-oriented design is to identify accurately the principal roles in an organization or process, to assign responsibilities to each of those roles, and to define the circumstances under which roles interact with one another. Each role is encapsulated in the form of an object. The object-oriented approach is quite different from traditional procedural methods, whose emphasis is on process. While a process-oriented model focuses on the sequencing of activities to accommodate chronological dependencies, an object-oriented model is concerned with the policies or conditions that constrain tasks to be performed. Object-oriented approach was described as follows by Wegner [118]:

“... the pieces of the design are objects which are grouped into classes for specification purposes. In addition to traditional dependencies between data elements, an inheritance relation between classes is used to express specializations and generalizations of the concepts represented by the classes.”

There are several fundamental concepts in object-oriented programming: class and object, encapsulation, inheritance, and polymorphism. The following gives a brief

description of these concepts. Details of object-oriented programming and its features can be found in many references [10, 92, 105, 113].

An object-oriented program is composed of **objects**, each with a number of attributes that define the state of the object. The behavior of an object is defined by its member methods, which are procedures for changing or returning the state of the object. An object's method is invoked when another object sends a *message* to the object. The function of an object-oriented program can be viewed as the interactions among the program's objects by sending and responding messages. The programming language implementation of certain type of objects is called a **class**, which defines the form and behavior of objects. A class typically consists of the following: a class interface that defines the member methods, private data that represents the attributes held privately by each object of the class, and member methods which implement the sequence of operations that can manipulate the private data. An object of a certain class can be created (also called *instantiated*) by invoking a special type of member methods in the class called *constructor*. The relationship between object and class can be viewed analogically in a procedural language as that a variable being a particular instance of a pre-defined type such as an integer.

Encapsulation in object-oriented programming means keeping the implementation details of a class private. Encapsulation is the ability to provide users with a well-defined interface to a set of functions in a way which both encourages and enforces the hiding of internal implementation details. In most object-oriented programming languages, encapsulation can be achieved by declaring access control on the member data and member functions of a class. Since encapsulation can hide complex issues and algorithms away from those that do not need to know the details about them, it is an effective mechanism to break down a complex system into manageable pieces. Encapsulation also plays an important role in ensuring that the implementation of a class can be changed without affecting other portions of the program.

To promote code reuse, object-oriented programming languages support class hierarchies, with data and methods of a *superclass* being inherited by its *subclasses*. This **inheritance** feature allows a programmer to define the common functions and data used by several classes at the highest possible level in the hierarchy, which avoids the duplication of data and methods at the lower levels. The subclasses may add additional attributes and methods, and can redefine the methods of a superclass if necessary. Inheritance makes it possible to restructure the information hierarchy so that it is less rigidly compartmentalized. The principal advantage of inheritance is that all the algorithms defined as part of the superclass are still valid for the subclasses, which can result in more reusable code since it is not necessary to rewrite the algorithms defined in the superclass.

In object-oriented programming, an object is *polymorphic* if it can be transparently used as instances of different types. **Polymorphism** allows the usage of different objects in the same code segment. The classic example is a group of classes representing different planar shapes: rectangles, circles, ovals, etc. Although these shapes share the same type of functions, such as drawing itself and calculating its area, the shapes perform these functions differently. Polymorphism allows us to write code in terms of generic shape type and have it work correctly for any actual shape. In object-oriented programming, the inheritance allows an object of a subclass to be treated as an object of a superclass.

The most widely cited advantage of object-oriented programming is the fact that objects can be used as software components. Objects embody data and functionalities that can be adopted by other programmers. The independent, modular nature of objects makes them ideally suited for reuse in other applications, without modification. At the same time, the ability to define subclasses means that the features of an object can be revised or added relatively easily. A well-designed object-oriented programming system enables programmers to independently develop and validate new code, to maintain and revise existing code, and to be able to modularly introduce software components.

2.1.2 Design and Implementation of Object-Oriented FEA Programs

The basic steps for the design of object-oriented FEA programs are identifying the main tasks performed in typical finite element analyses, abstracting them into separate classes, and then specifying interfaces for these classes. It is important that the interfaces specified can facilitate the classes to work together to perform the requested analyses and allow new developments to be introduced without the need to dramatically change the existing code.

The classes for an object-oriented FEA program need to be designed in cope with the basic steps of a finite element analysis, which include the discretization of the model into elements and nodes, the formulation of element matrices and vectors, the assembly of element matrices and vectors into the system of equations, the incorporation of the boundary conditions, the solution of the linear equations and/or eigen systems, and the computation of responses for each element. Most of the early object-oriented FEA programs (for example, see [36, 72, 121]) concentrated on fairly straightforward implementations of finite element programs in an object-oriented language – separate objects were created for elements, nodes, loads, constraints, materials, degree of freedoms, and analyses etc. The classes introduced in these object-oriented FEA programs can be grouped into three basic categories:

- Numerical classes to handle the numerical operations in the solution procedure.
- Model classes to create a finite element model to represent the model in terms of elements, nodes, loads, and constraints, and to store the analysis results.
- Analysis classes to perform the analysis of the finite element model, i.e. form and solve the system equations.

Finite element analysis involves intensive numerical computations. Therefore, the most obvious classes in an object-oriented FEA program are defined for the basic numerical quantities such as vectors and matrices. The matrix and vector classes are employed in an object-oriented FEA program to store and pass information between the objects in the system and to perform numerical computations [4, 36, 65, 72, 89, 121]. A number of researchers have focused on developing specific software packages for matrix and vector computation [66, 107, 120]. These packages can be tightly integrated into finite element analysis programs. A matrix object is defined in terms of its data and functions: the data are the entries in the matrix and the functions are corresponding to the basic matrix operations of addition, subtraction, multiplication, inversion, and transposition. Subclasses of matrix class can be defined for matrices with special structures, such as symmetric, upper triangular, lower triangular, sparse, band, symmetric band, and profile matrices [66, 120]. A vector can also be defined as a subclass of matrix; however, because of its substantial usage in finite element programs, vector is often defined as a separate class.

In most of the work that has been presented, the main class abstractions used to describe the finite element model are: Node, Element, Constraint, and Load [4, 13, 27, 36, 104, 121]. The abstractions of these objects are similar to those used in traditional procedural-based finite element programs. The aggregation of these model objects forms a Domain object, which has many different names in the literature: NAP [36], LocalDB [81], Assemblage [103], Partition [104], FE_Model [73], Model [4], and Domain [13, 121]. The main functionality of the Domain class can be divided into two categories. One is responsible for adding model components to and removing them from the Domain object. The other is for accessing the Domain components. One of the prominent features of most object-oriented finite element analysis programs is the flexibility and extendibility with which new elements can be easily introduced. The role and functionalities of elements in a FEA program are well studied, and hence the Element class interface is generally well defined. The features of object-oriented design, especially encapsulation and inheritance, can be utilized to facilitate the integration of new elements. In most

object-oriented FEA implementations, a new element can be introduced by directly adding an Element subclass.

A finite element analysis involves forming the system of equations, applying the boundary conditions, solving the system of equations, and updating the response quantities at the nodes and elements. A well-designed analysis framework should allow solution algorithms to be easily modified or added. In an object-oriented finite element analysis program, the flexibility of modifying analysis types is achieved by the ease of introducing subclasses and the collaboration among classes. An object-oriented FEA program typically models analysis algorithms in several coupled classes. For instance, Pidaparti and Hudli [97] presented a design with EigenSolution and DirectIntegrator to handle dynamic analysis. Rucki and Miller [104] provided three base classes, AlgorithmManager, Algorithm, and AlgorithmicAgent, to perform the analysis. The AlgorithmManager object is responsible for managing its contained Algorithm objects, and the AlgorithmicAgent acts as an intermediary between the Algorithm object and its associated Domain object. Archer [4] presented five classes, which are Analysis, ConstraintHandler, RecorderHandler, Map, and MatrixHandler, to perform the analysis.

2.1.3 OpenSees

OpenSees (Open System for Earthquake Engineering Simulation) [76] is an object-oriented software framework to facilitate the simulation of the seismic response of structural and geotechnical systems. OpenSees is sponsored by PEER (Pacific Earthquake Engineering Research) center, and is intended to serve as the computational platform for research in performance-based earthquake engineering at PEER center. The goal of the OpenSees development is to improve the modeling and computational simulation in earthquake engineering through open-source development. The following briefly discusses the features of OpenSees. The discussion will be focused on the object-oriented design of the class interfaces and the interaction among the classes. Similar to

most object-oriented FEA programs, the classes introduced in OpenSees can also be categorized into numerical classes, model classes and analysis classes.

OpenSees consists of three types of basic numerical classes; they are the Matrix, Vector and ID classes. The ID class is just a special form of vector for handling integers. The objects of these numerical classes are used primarily to store and communicate information, e.g. stiffness and load information. Both Matrix and Vector classes provide a full range of functions to handle numerical computations, typically in the form of *overloaded* operator functions. Matrices of special structures (e.g. band, profile, sparse, etc.) are not defined as subclasses of the Matrix class in OpenSees. Instead, since the special structured matrices are primarily used during the solution phase, the SystemOfEqn class is introduced to handle these special matrices.

Similar to the abstractions used in most of the traditional FEA programs and the object-oriented FEA programs, the main class abstractions adopted in OpenSees to describe a finite element model are: Node, Element, Constrain, Load, and Domain, etc. Figure 2.1 depicts the main class abstractions in OpenSees and the relationship among the classes using the Rumbaugh [105] notation. Details on each class and its interface can be found in McKenna [76]. The Rumbaugh notation uses a rectangle to represent a class, and a line connecting two classes to represent the relationship between the two classes. There are three types of relationships:

- The association relationship exists between classes when an object of one class *knows* about an object of another class. For example, an Element object knows about its Node objects. The Rumbaugh notation uses a line between two rectangles to represent the association relationship.
- The inheritance relationship exists between the superclass and its subclasses. The inheritance allows an instance of a subclass to be treated as an instance of its superclass. For example, since the Truss class is the subclass of the Element class, a Truss object can be treated as an Element object. The inheritance relationship is

represented by a line with triangle between the classes. The subclasses that share a common superclass are shown by lines connecting to the base of the triangle.

- The aggregation relationship exists when an object of one class is made up of component objects of other classes. For example, a Domain object is an aggregation of Element, Node, Load, and Constraint objects. The aggregation relationship is represented with a diamond at the aggregate class and a line from the diamond to the classes of the component objects.

As shown in Figure 2.1, the ModelBuilder class defined in OpenSees is responsible for creating finite element models, i.e. creating the nodes, elements, loads, and constraints. The ModelBuilder class defines one pure virtual method, `buildFE_Model()`, which can be invoked to create a finite element model. Subclasses of ModelBuilder must provide an implementation of the method so that different types of finite element models can be created. The usage of the ModelBuilder class hierarchy keeps OpenSees extendible. Each ModelBuilder object, as shown in Figure 2.1, is associated with a single Domain object, which acts as a repository for domain components. When `buildFE_Model()` is invoked on a ModelBuilder object, the object builds the components of the model and then adds the component objects to the Domain object. The manner in which the ModelBuilder object creates the model components depends on the subclass of the ModelBuidler that is chosen to perform the analysis. This approach allows an appropriate subclass of ModelBuilder to be used for creating certain type of finite element models.

In OpenSees, a Domain object is associated with a ModelBuider object and an Analysis object, as shown in Figure 2.1. The ModelBuilder object is responsible for populating the Domain object by creating the model component objects and then adding them to the Domain object. The Analysis object is responsible for analyzing the populated Domain object.

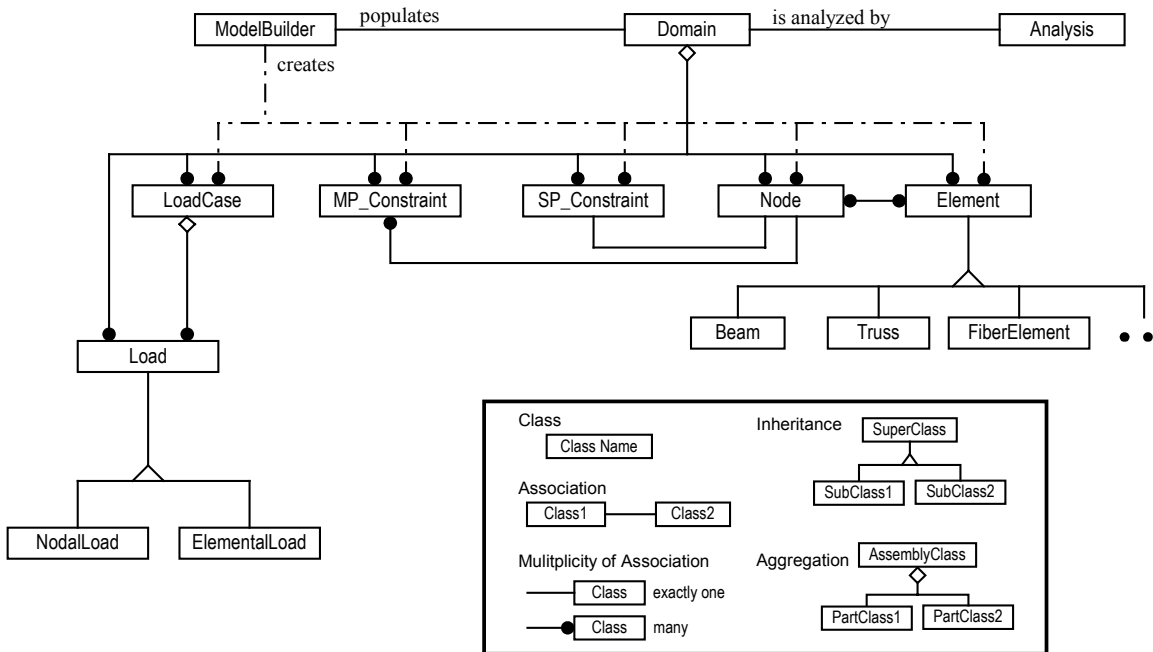

Figure 2.1: Class Abstraction in OpenSees (from [76])

The basic functionality of an Element object is to provide the current stiffness, mass, and damping matrices, and the residual force vector due to the current stresses and element loads. The Element class defined in OpenSees is an abstract base class, which defines the interface that all subclasses must provide. Normally a new type of element can be introduced by simply implementing a new Element subclass, which is usually a process incurs no changes to the existing code in the program. It should be noted that most finite element analysis programs written in procedural languages also provide facilities for adding elements. However, the object-oriented approach can better isolate the element functions from analysis and solution algorithm functions. Object-oriented approach allows inheritance of common functions, and allows the Element objects to store as much private data as it required by the element. It is this level of abstraction that facilitates the concurrent development of new elements and makes the development of distributed element services easier.

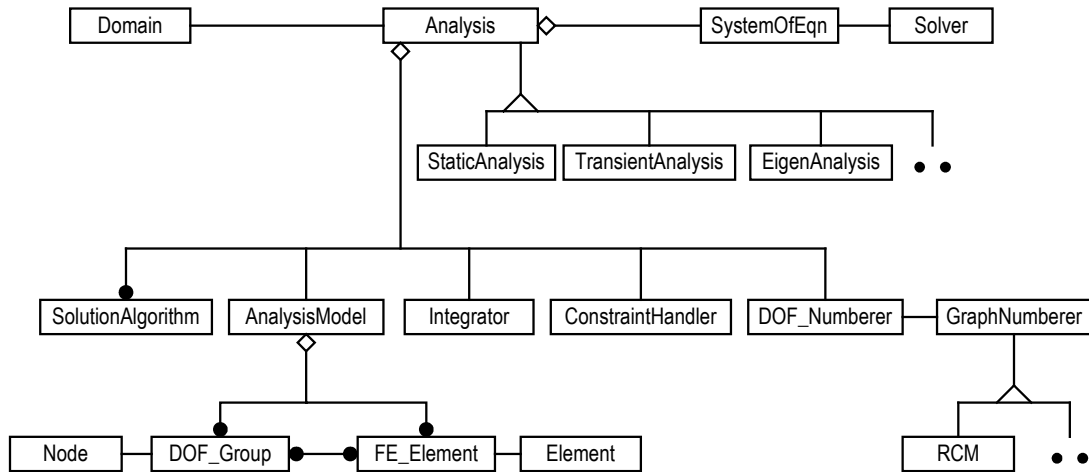

Figure 2.2: Class Diagram for OpenSees Analysis Framework (from [76])

For a finite element program, the ability to choose the type of analysis performed on the analysis model is as important as changing element types. The typical object-oriented approach that has been taken to the Analysis class design [4, 27, 36, 97, 121] is similar to the black-box approach of traditional finite element programming. With this approach, a number of subclasses of Analysis are provided, and each of these Analysis subclasses is associated with one type of analysis (e.g. linear, transient, etc.). The hierarchy representing the Analysis classes is very flat, which is not efficient to facilitate code reuse. To provide a design that is more flexible and extendible than the typical approach, the main tasks performed in a finite element analysis need to be identified, and separate classes can be abstracted for these tasks. The class diagram of OpenSees analysis framework is shown in Figure 2.2. As depicted in the figure, OpenSees uses an aggregation of classes to represent Analysis, which includes SolutionAlgorithm, AnalysisModel, Integrator, ConstraintHandler, DOF_Numberer and SystemOfEqn.

2.2 Direct Module Integration

As technologies and structural theories advance, finite element analysis software packages need to be able to accommodate new developments in element formulation, material relations, analysis strategies, solution strategies, as well as computing environments. For most existing finite element software packages, modifying or extending the code requires that the developers have intimate knowledge of the data structures and what procedures affect what portions of the code. The ability to reuse code from other sources is limited, because data structures vary widely between programs. Consequently, introducing code from other sources often requires that the code be modified to suit the data structure used in the finite element program. The modification of one portion of the program may also have ripple effect that results in dramatic code changes in other parts of the program.

To support better data encapsulation and to facilitate code reuse, object-oriented programming paradigm can be utilized for the finite element program development. A key feature of object-oriented FEA programs is the interchangeability of components and the ability to integrate existing libraries and new components into the framework without the need to change the existing code. The flexibility and extendibility of these programs are based on the object-oriented support of abstraction, encapsulation, inheritance, and polymorphism. Extending existing programs by incorporating external modules normally requires one or several subclasses to be introduced.

In the following, a number of examples of module extension are presented. Several approaches for incorporating different types of software components are discussed. To illustrate the principles and ideas without losing generality, we employ OpenSees as the core platform. Similar techniques can be applied to other object-oriented FEA programs for integrating external software modules.

2.2.1 Incorporating New Developments

One of the benefits of object-oriented software design is that new developed code can be incorporated as one or several new classes. Because of the encapsulation and inheritance features of object-oriented design, the integration process tends to be modular and incurs no modifications to the existing code. For an object-oriented FEA program, the ease of incorporating new developments and existing libraries also holds. Since the base classes for a typical object-oriented FEA program are already defined, new elements, new material types, new analysis strategies, and new solution strategies can be introduced by creating new subclasses of the defined classes. This process can be exemplified with the modular integration of a new element. In this section, we describe the process of modular extension of an object-oriented FEA program through introducing subclasses, using the integration of an eight-node quadrilateral element as an example.

We illustrate an implementation of an eight-node quadrilateral element. The core of the element is implemented in Fortran, which remains to be a popular language by engineers to develop element routines. The main function of the element routine is to calculate the stiffness matrix of the isoparametric quadrilateral element for axisymmetric, plan strain, and plain stress conditions. The interface of the Fortran-based routine is:

```
SUBROUTINE QUAD8STIFF(Nel, Itype, Nint, Th, E, Pr, Cord, Stiff)
```

where `Nel` is the element number in the model; `Itype` defines whether the element is axisymmetric, plain strain, or plain stress; `Nint` defines the Gauss numerical integration order; `Th` is the thickness of the element; `E` is the Young's modulus and `Pr` is the Poisson's ratio; `Cord` is the element nodal coordinates; and `Stiff` is the calculated element stiffness matrix.

To incorporate this element into OpenSees, a new subclass of `Element` need to be created. The new class, named `QuadEightElement`, is implemented in C++, which is the same language used to implement OpenSees. Since the `QuadEightElement` class is

implemented in C++, two files are created. The `QuadEightElement.h` file defines the class interface, and the `QuadEightElement.cpp` file provides the implementation. Besides defining the methods interfaces, the `QuadEightElement.h` file also defines the *private* data of the class. In this case, the *private* data include the information related to the element such as the element number, the type of the element, the thickness of the element, Young's modulus, Poisson's ratio, and pointers to the Node and Load objects that associated with the element.

The interface of the `QuadEightElement` class is similar to the interface of the `Element` base class. The `getTangentStiff()` method is the method that encapsulates the developed Fortran code and uses the existing code to calculate the element stiffness matrix. Part of the implementation of the `getTangentStiff()` method is shown in Figure 2.3. The Fortran function `QUAD8STIFF()` is accessed by attaching a underscore at the end of the function name, which signals the C++ compiler that an external procedure needs to be invoked. Since the default behavior of function parameters is *passing by reference* in Fortran and *passing by value* in C/C++, the parameters of `QUAD8STIFF()` need to be references (also called pointers in C/C++ terminology). This can be achieved by applying the operator `&` in front of the parameters to obtain their references.

As illustrated in the example, a new element can be developed and linked rather easily with an object-oriented FEA program as a subclass. The example also shows that the element routines can be implemented using most common languages (e.g. Fortran, C, C++, etc.), and can still be integrated with the object-oriented FEA program. Although this example only illustrates the integration of a new element, other types of new developments can also be introduced to the object-oriented FEA program as subclasses; for example, new materials, new solution strategies, etc.

```
const Matrix& QuadEightElement::getTangentStiff()  
{  
    double Stiff[16][16];  
    double* Cord = wrapCord();  
  
    QUAD8STIFF_(&Nel, &Itype, &Nint, &Th, &E, &Pr, Cord, Stiff);  
  
    Matrix eleK = new Matrix(Stiff, 16, 16);  
    return Matrix;  
}
```

Figure 2.3: Pseudo-Code for getTangentStiff Method of QuadEightElement Class

2.2.2 Linking Software Components

To facilitate and improve a software application in a cost-effective manner, external software components can be incorporated as *building blocks* to construct a more sophisticated system. Software components normally consist of functions with similar interfaces and operations. One example is BLAS (Basic Linear Algebra Subprograms) [58], which consists of high quality routines for performing basic vector and matrix operations. Another example is LAPACK [2], which provides routines for solving systems of simultaneous linear equations, least-squares solutions of linear systems of equations, eigenvalue problems, and single value decomposition problems. These software components, as well as COTS (commercially off-the-shelf) components, tend to have clear and consistent interfaces, which can facilitate the integration process. These software components are usually provided in the form of software libraries or packaged source-code files.

There are many popular numerical analysis packages that can be integrated with FEA programs to enhance the analysis capabilities and improve the system performance. Besides the linear algebra packages BLAS and LAPACK, there are linear solvers SuperLU [22] and UMFPACK [21], eigensolver ARPACK [59], graph partitioning and

ordering package METIS [52], and other software components. In the original developed OpenSees, the packages BLAS, LAPACK, SuperLU, and UMFPACK have already been incorporated [76]. In the following, we use the integration of METIS version 4.0 with OpenSees to illustrate the process of incorporating off-the-shelf software components.

METIS is a software package for partitioning large irregular graphs, partitioning large meshes, and computing fill-reducing ordering of sparse matrices [52]. The algorithms in METIS are based on multilevel graph partitioning [53, 54]. METIS provides both stand-alone programs (executable files) and library interfaces (functions). To keep the integration flexible, we choose to use the library interfaces. We are particularly interested in the usages of two METIS functions:

- `METIS_PartGraphVKway()`, which is used to partition a graph into k equal-size parts using the multilevel k -way partitioning algorithm. The objective of the partitioning is to minimize the total communication volume. This routine can be used for domain decomposition, which is an important step for parallel finite element analysis.
- `METIS_NodeND()`, which is a function to compute fill-reducing orderings of sparse matrices using the multilevel nested dissection algorithm. The nested dissection paradigm is based on computing a vertex-separator for the graph corresponding to the matrix. The nodes in the separator are moved to the end of the matrix, and a similar process is applied recursively for each one of the other two parts. This routine is very useful for generating the ordering for sparse linear solver so that the storage of the sparse matrix can be reduced.

The details of these two functions and their interfaces can be found in METIS manual [52]. Both functions have input parameters `xadj` and `adjncy`, which are two arrays used to represent the adjacency structure of a graph.

2.2.2.1 Graph Representation of Matrices

Graph theory plays a significant role in the study of sparse matrices [40]. A graph $G = (X, E)$ consists of a finite set of *nodes* or *vertices* together with a set of *edges*, which are unordered pairs of vertices. The structure of a matrix can be symbolically represented as a graph, where the row (or column) number of the matrix represents the vertices and the non-zero entries of the matrix corresponds to edges. For example, if a_{36} is a non-zero entry of the matrix A , then we have an edge from vertex 3 to vertex 6 in the graph that represents the matrix.

The adjacency structure of a graph can be stored using a compressed storage format (CSR). In this format, the adjacency structure of a graph with n vertices and m edges is represented using two arrays `xadj` and `adjncy`. The `xadj` array is of size $n+1$, and the `adjncy` is of size $2m$. The size of `adjncy` is $2m$ instead of m is because for each edge between vertices x and y , we actually store both (x, y) and (y, x) .

The CSR storage of a graph is as follows. The adjacency list of vertex i is stored in array `adjncy` starting at index `xadj[i]` and ending at (but not including) `xadj[i+1]`. That is, for each vertex i , its adjacency list is stored in consecutive locations in the array `adjncy`, and the array `xadj` is used to indicate where the adjacent vertices of i begins and ends. Figure 2.4(a) shows an example of a sparse matrix, with the number and * denoting the nonzero entries. Figure 2.4(b) is the graph representation of the matrix, and Figure 2.4(c) illustrates the CSR storage of the adjacency structure of the graph.

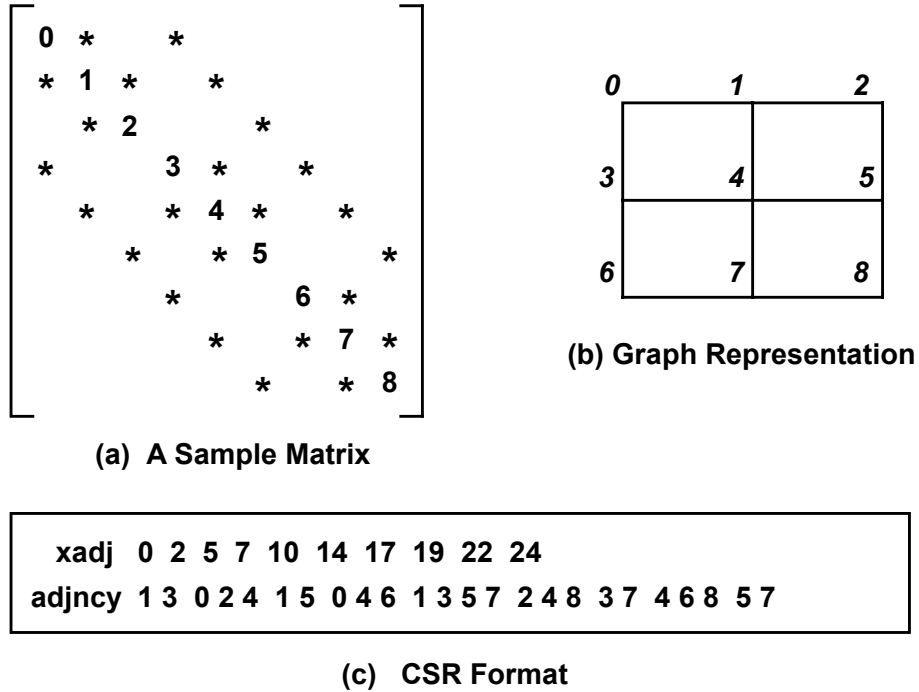

Figure 2.4: An Example of the CSR Storage for Matrix Structure

2.2.2.2 Linking METIS Routines

The linkage of the routines to OpenSees depends on the usage of individual routine in the software package. For the integration of `METIS_PartGraphVKway()`, which is the routine to partition a graph into k equal-size parts, a new class is introduced to OpenSees. The new class is named `MetisPartitioner`, whose interface is shown in Figure 2.5. Besides the constructor and destructor, the class interface defines three methods: `setOptions()` is used to set certain options for the METIS partitioning routine; `setDefaultOptions()` is used to set the default option values; and `partition()` is the method that uses the METIS routine to partition the input graph. The pseudo code for the implementation of `partition()` method is presented in Figure 2.6, which shows the usage of the METIS routine.

```

class MetisPartitioner : public Partitioner
{
public:
    Metis(int numParts =1);
    ~Metis();

    bool setOptions(int wgtflag, int numflag, int* options);
    bool setDefaultOptions(void);

    int partition(Graph &theGraph, int numParts);
}

```

Figure 2.5: Class Interface for the MetisPartitioner Class

```

int MetisPartitioner::partition(Graph &theGraph, int numParts)
{
    // set up the data structures that METIS need
    int numVertex = theGraph.getNumVertex();
    int numEdge = theGraph.getNumEdge();
    int *xadj = new int [numVertex+2];
    int *adjncy = new int [2*numEdge];
    int numflag = 0; // use C-stype numbering for arrays
    int wgtflag = 0; // no weights on the graph
    ... ..

    // build (xadj, adjncy) from the input Graph
    buildAdj(theGraph, xadj, adjncy);

    // we now access the METIS routine
    METIS_PartGraphVKway(&numVertex, xadj, adjncy, vwgt, vsize,
        &wgtflag, &numflag, &numParts, options, &volume, part);

    // set the vertex corresponding to the partitioned scheme
    for (int vert =0; vert<numVertex; vert++) {
        vertexPtr = theGraph.getVertexPtr(vert+START_VERTEX_NUM);
        vertexPtr->setColor(part[vert]+1);
    }
}

```

Figure 2.6: Pseudo-Code for partition Method of MetisPartitioner Class

The `METIS_NodeND()` method is incorporated into OpenSees using a different approach. Since `METIS_NodeND()` is used to compute the fill-reducing orderings of sparse matrices, it is more appropriate to combine this method with sparse linear solvers

than encapsulate it in a new class. For most linear sparse solvers, e.g. SymSparse [69], the nodes of the finite element model are reordered first to reduce the bandwidth or the fill-in of the matrix factors. This procedure is called *symbolic factorization*, in which graph ordering routines play an important role. One of the ordering routines integrated with OpenSees is called `multind()` and the `METIS_NodeND()` method is incorporated in this routine, as shown in Figure 2.7. The inputs to the `multind()` method are the `xadj` and `adjncy` pair, and the outputs are `perm` and `invp` arrays, which store the computed ordering of the input graph.

When the software components have clearly defined interfaces, which are the case for most off-the-shelf software packages and components, these components can easily be integrated with an object-oriented FEA program as illustrated in this example. The key step is to identify the inputs and outputs to the software components. The routines in the components can then be incorporated by defining the option variables and converting the data format properly according to the requirements of the routines.

2.2.3 Integration of Legacy Applications

The difference between a legacy application and an off-the-shelf component is that legacy application is usually not originally designed for adoption, that is, not for combination with other libraries or routines. Thereby, the interfaces are not necessarily clearly defined. To integrate a legacy application into an object-oriented FEA program, the most important step is to identify the main procedures of the legacy application. The identified procedures can then be packaged by adding clearly defined interfaces. In this section, we will use the integration of a sparse linear direct solver (SymSparse) with OpenSees to illustrate the process of incorporating legacy applications to an object-oriented FEA program.

```
void multind(int *neq, int* xadj, int* adjncy, int* perm, int* invp)
{
    int numflag = 0;
    int options[10];
    options[0] = 0;

    METIS_NodeND(neq, xadj, adjncy, &numflag, options, perm, invp);
}
```

Figure 2.7: Pseudo-Code for Incorporating METIS_NodeND Method

2.2.3.1 Procedures of SymSparse Direct Solver

A typical finite element analysis often requires the solution of a linear system of equations. There are many numerical strategies for solving the system of equations, which fall into two general categories, *iterative* and *direct*. A typical iterative method involves the initial selection of an approximated solution, and the determination of a sequence of trial solutions that approach to the solution. Direct solvers are normally categorized by the data structure of the global matrix and the numerical algorithm used to perform the factorization. A variable bandwidth solver (also called profile solver) is perhaps the most commonly used direct solution method in structural finite element analysis programs [5, 48]. There are also a number of sparse direct solvers, including, SuperLU [22], UMFPACK [21], and SymSparse [69], etc.

This work focuses on integrating SymSparse solver into OpenSees. SymSparse is a generalized sparse/profile linear direct solver for symmetric positive definite systems. SymSparse is originally implemented in C language and integrated with DLEARN [48], a linear static and dynamic finite element analysis program. SymSparse can be used as a profile solver as well as a sparse solution solver, depending on the physical model and the ordering scheme used. SymSparse can be used in a finite element program to solve a linear system of equations $Ku = f$, where u and f are respectively the displacement and loading vectors. K is the global stiffness matrix which is often symmetric, positive

definite and sparse in finite element analysis. The solution method is based on a numerical algorithm known as *Cholesky's method*, which is a symmetric variant of Gaussian elimination tailored to symmetric positive definite matrices. During the solution process, the symmetric matrix A is first factored into its matrix product, $K = LDL^T$, where D is a diagonal matrix and L is the lower triangular matrix factor. The displacement vector u is then computed by a forward solve, $z = (DL^T)^{-1} f$, followed by a backward substitution, $u = L^{-1}z$.

One important fact about the Cholesky factorization of a sparse matrix is that the matrix usually suffers *fill-in*. That is, the matrix factor L has nonzeros in positions which are zero in the lower triangular part of the matrix K . Therefore, in order to save storage requirement, data structure needs to be set up for the matrix factor L before the numerical calculation; and the same data structure can be used to store the lower triangular part of matrix K . The SymSparse solver includes a symbolic factorization procedure that determines and sets up the data structure for the sparse matrix factor L directly. Dynamic memory allocation is used extensively in SymSparse to set up the data structure. This one-step approach to establish the data structure for matrix factor is generally more efficient than the two-step approach adopted in [64], which uses symbolic factorization to determine the structure of the Cholesky factor first and then set up the data structure based on the Cholesky structure.

Since SymSparse was originally developed to use with DLEARN [48], a procedural finite element analysis program, we first need to identify the major procedures in SymSparse in order to integrate it with an object-oriented FEA program. There are three main tasks identified for the SymSparse solver, and these three main procedures are packaged with clearly defined interfaces. For the interfaces shown in the following functions, the matrix factor L and its data structure LS are only defined for illustration purpose. The details regarding the data structure are presented in Mackay et al. [69].

- `symbolicFact(neq, xadj, adjncy, invp, Ls)`
Given the number of equations (`neq`) and the adjacency structure (`xadj`, `adjncy`) of a matrix, this symbolic factorization routine determines the matrix ordering `invp` and a data structure for the matrix factor, indicated as `Ls`. The input graph is first ordered by a graph fill-reducing ordering routine. Currently, the ordering routines included are RCM [39], Minimum Degree [116], Generalized Nested Dissection [62], and Multilevel Nested Dissection [53]. After the ordering, an ordered elimination tree can be established, and then a topological post-ordering strategy is used to re-order the nodes so that the nodes in any subtree of the elimination tree are numbered consecutively [63]. The last step of this function is to set up the appropriate data structure `Ls` for the matrix factor.
- `assemble(ES, LM, invp, Ls, L)`
Once the data structure for the matrix factor has been set up, the `assemble()` routine can be invoked to assemble the element stiffness matrices. The same data structure for the matrix factor can be used to store the assembled matrix. In the assembly process, each entry of the element stiffness matrix is summed into the appropriate location directly into the data structure of the matrix factor. The process is repeated for each element and until all elements in the domain are assembled. The inputs to the function are element stiffness matrix (`ES`), the element-node incidence array (`LM`), the ordering (`invp`), and the data structure of matrix factor (`Ls`). The output of the function is the assembled matrix (`L`).
- `pfsfct(L)` and `pfsslv(L, force, disp)`
These two functions are used to perform the numerical calculation. The function `pfsfct()` performs the numerical factorization of the input matrix `L`. The same data structure is used to save both the matrix and its factor. Given the matrix factor `L` and the force vector `force`, the function `pfsslv()` performs the forward and backward substitutions to compute the displacement solution (`disp`).

2.2.3.2 Integration of SymSparse Direct Solver

Since different linear solvers are developed with different data structures, the base classes for integrating solvers into an object-oriented FEA program need to be extendible. There are two classes defined in OpenSees to store and solve the system of equations used in the analysis. The `SystemOfEqn` class is responsible for storing the systems of equations, and the `Solver` class is responsible for performing the numerical operations. To seamlessly integrate the SymSparse solver into OpenSees, two new subclasses are introduced: `SymSparseLinSOE` and `SymSparseLinSolver`.

The `SymSparseLinSOE` class, whose interface is shown in Figure 2.8, provides the following methods:

- `setSize()`: This method is used essentially to perform the symbolic factorization, which is a process to determine the data structure of matrix factor A . The function `symbolicFact()` from SymSparse is incorporated in this method to determine the data structure of matrix factor based on the input `Graph` object.
- `addA()` and `addB()` are provided to assemble the global stiffness matrix A and force vector b . The `addA()` invokes the function `assemble()` from SymSparse to assemble the element stiffness matrices. The input parameters to `addA()` are element stiffness matrix and the element-node incidence array.
- `solve()` is provided to perform the numerical solution of the systems of equations. The default behavior of this method is to invoke the `solve()` method on the associated `SymSparseLinSolver` object.
- Several methods are provided to return the information of the system and the computed results, such as the number of equations, the right-hand-side vector b , and the solution vector x .

```
class SymSparseLinSOE : public SystemOfEqn
{
public:
    LinearSOE(LinearSOESolver &theSolver, int classTag);
    virtual ~LinearSOE();

    virtual int solve(void);

    // pure virtual functions
    virtual int setSize(Graph &theGraph);

    virtual int addA(const Matrix &ES, const ID &LM, double fact);
    virtual int addB(const Vector &f, const ID &LM, double fact);
    virtual int setB(const Vector &, double fact)=0;

    virtual void zeroA(void);
    virtual void zeroB(void);

    virtual int getNumEqn(void) const;
    virtual const Vector &getX(void);
    virtual const Vector &getB(void);
    virtual double getDeterminant(void);
    virtual double normRHS(void);

    virtual void setX(int loc, double value);
    virtual void setX(const Vector &X);
}
```

Figure 2.8: Interface for the SymSparseLinSOE Class

The SymSparseLinSolver object is responsible for performing numerical operations on the systems of equations. The SymSparseLinSolver class defines one method `solve()`, which invokes the `pfsfct()` and `pfsslv()` from SymSparse to factor the global stiffness matrix and to perform the forward and backward substitutions. The matrix `A` and vector `b` used in the solver are accessed from the associated SymSparseLinSOE object and the solution `x` is stored back to the SymSparseLinSOE object. The control flow of the integrated linear solver is depicted in Figure 2.9, where the numbers indicate the chronological sequences of function invocations.

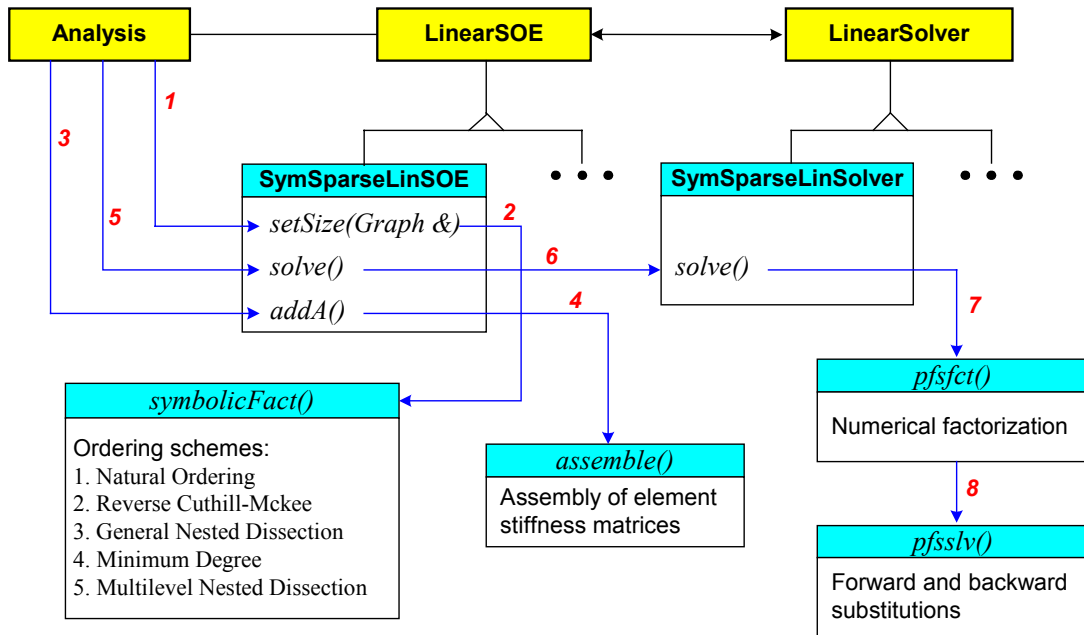

Figure 2.9: The Control Flow of Integrating the SymSparse Linear Solver

2.3 Model Integration with Reverse Communication Interface

Another mechanism for software component integration is reverse communication, which is an interface that allows the users to freely choose any convenient data structure for part of the operations. The reverse communication technique has been implemented within the eigensolver package ARPACK [59] to allow users to provide the matrix computation through subroutine calls or code segments. An object-oriented FEA program can also take advantage of such mechanism to integrate software components. This section shows the example of extending the OpenSees core for eigenvalue analysis, and the examples of incorporating eigensolvers through reverse communication interface.

2.3.1 Reverse Communication Interface

For certain special function libraries and linear algebra libraries for dense matrices (e.g. BLAS [58] and LAPACK [2]), the data structures are simple and natural for the applications. However, this is hardly the case for the modern generation of sophisticated numerical applications, where the problem is large and complex, and a significant amount of design and coding are related to data structures. For instance, there are a large number of different data structures developed for sparse matrices, which makes it difficult to develop a numerical application that accommodates all possible cases. One obvious solution would be to limit the number of possible data storage schemes and to transform the data structures to a few possible supported choices, using transformation routines from libraries such as SPARSKIT [106]. However, limiting the number of possible data storage schemes is not convenient for the user, and may incur performance penalties because the data transformation can be *expensive* to perform.

Another approach to handle the diverse application data structures is using reverse communication interface as implemented in ARPACK [59]. In this approach, routines that need to use the application data structures set a flag and return to the users. For the applications involved with sparse matrices, reverse communication means that a data storage scheme is not enforced on the matrices. The matrix itself is not needed in the main drive of the application, but rather the matrix operations are required to be provided by the users.

The reverse communication mechanism can be applied to many types of applications; one of such is the eigensolver. A typical generalized eigensolver requires vector-only operations and matrix-dependent operations, such as matrix-vector multiplication $M \cdot x$ and the solution of linear equations $A \cdot x = b$. Since the vectors are usually stored as contiguous arrays of bytes, the vector-only operations are implemented within the eigensolver. The matrix-dependent operations, on the other hand, are handled in a user-defined way. The main loop of the eigensolver can set up several flags and ask the user

to provide appropriate matrix-dependent operations whenever needed. The reverse communication allows the user to choose any appropriate data storage structure for matrices, as well as the implementations of the key matrix-dependent operations.

Reverse communication does impose a slight overhead to the program because of the increased number of function calls required. However, as can be expected for large problems, this overhead is likely to be small compared to the cost of the numerical operations. Another concern is that reverse communication shifts the responsibility of performing the matrix dependent operations to the users. As a result, it is difficult for the iterative routines to check whether a failure resides in the method itself or in the user's implementation of the matrix operations. Therefore, the error detection and error handling are the key design factors for reverse communication interface. A properly designed reverse communication interface needs to provide a means to trace the progress of the computation as it proceeds, and to report to the user the error types by different error flags.

2.3.2 Incorporating Eigensolvers with OpenSees

Linear structural stability and dynamic analysis problems involve the solution of linear eigenvalue problems. In this work, we focus on the solution of the generalized eigenvalue problem $Ax = \lambda Mx$. The generalized eigenvalue problem is often encountered in structural dynamic analysis, where the stiffness matrix A is symmetric positive definite and the mass matrix M is symmetric positive definite or semi-definite. The eigenpair λ and x provide approximations to the natural frequencies and vibration modes of the structure. Details of the eigenvalue problems can be found in standard books on matrix computation (for example, see Golub and Van Loan [43]).

The original OpenSees core can be extended to incorporate eigen analysis. The class diagram for the extended framework is shown in Figure 2.10. The introduced classes are EigenAnalysis, EigenAlgorithm, EigenIntegrator, EigenSOE and EigenSolver.

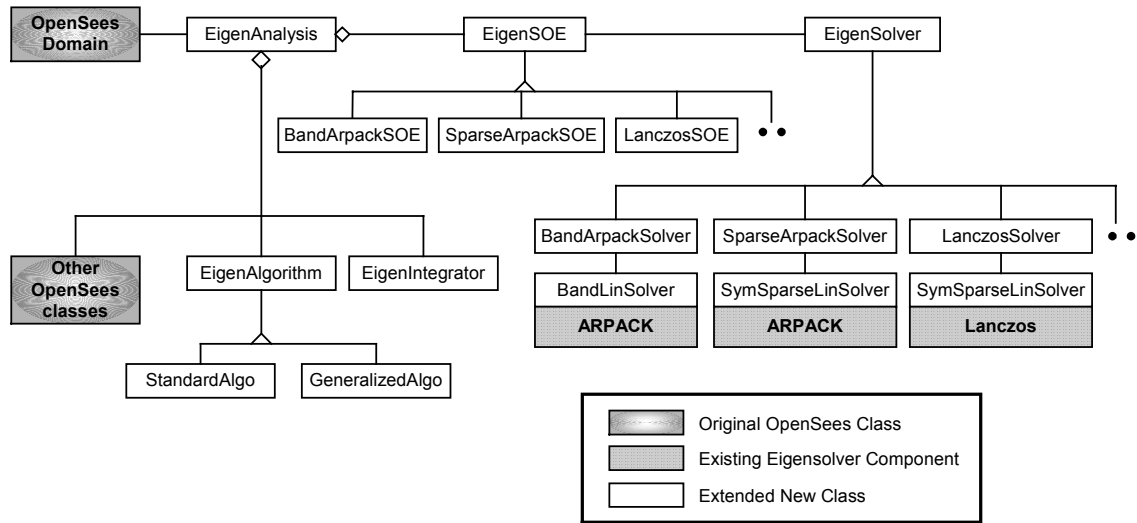

Figure 2.10: Class Diagram for Eigenvalue Analysis in OpenSees

Two eigensolvers, ARPACK and Lanczos eigensolver, are integrated with OpenSees to facilitate structural stability and dynamic analyses. Three new subclasses of EigenSOE and three new subclasses of EigenSolver are implemented in OpenSees. The BandArpackSOE and BandArpackSolver classes are developed to integrate ARPACK and a band solver, the SparseArpackSOE and SparseArpackSolver classes are introduced to integrate ARPACK by using the SymSparse solver as linear solver, and the LanczosSOE and LanczosSolver are developed to integrate the Lanczos eigensolver by using the SymSparse solver. The relationships of these classes with other OpenSees classes are depicted in Figure 2.10.

ARPACK [59] stands for Arnoldi PACKage, which is a collection of Fortran subroutines designed to solve large-scale eigenvalue problems. ARPACK software is capable of solving non-Hermitian standard and generalized eigenvalue problems. The software is designed to compute a few eigenvalues with user specified features such as those of largest real part or smallest magnitude. The corresponding eigenvectors can also be obtained upon the users' requests. ARPACK is based upon an algorithmic variant of the Arnoldi process called the Implicitly Restarted Arnoldi Method (IRAM). The shift and

invert spectral transformation is used in ARPACK to enhance convergence to a desired portion of the eigenvalue spectrum. If (x, λ) is a generalized eigenpair and $\sigma \neq \lambda$ then

$$(A - \sigma M)^{-1} Mx = x\nu \quad \text{where} \quad \nu = \frac{1}{\lambda - \sigma}$$

This transformation is effective for finding eigenvalues near σ .

One of the salient features of ARPACK is the reverse communication, which allows the user to provide matrix-dependent operations. In order to use ARPACK to solve generalized eigenvalue problems, two operations need to be provided by the user: one is matrix-vector multiplication $z \leftarrow Mx$, and the other is a linear equation solver $x \leftarrow (A - \sigma M)^{-1} y$.

- If the operation of matrix-vector multiplication is performed in the global level, the operation requires the assembly of element mass matrices, which is an expensive operation in terms of both processing time and extra storage space. To improve performance and minimize storage requirement, the operation $z \leftarrow Mx$ can be performed using an element-by-element strategy. The mass matrix stored in each element is retrieved to multiply with part of the vector x . The generated result vector can then be assembled to obtain z . Compared with global matrix (two-dimensional) assembly, this global vector (one-dimensional) assembly is much cheaper.
- For the solution of linear equations $x \leftarrow (A - \sigma M)^{-1} y$, an efficient linear solver can be used. Since the matrix $(A - \sigma M)$ generated from dynamic analyses is normally sparse, symmetric and positive definite, the SymSparse solver can be integrated to provide the linear equation solving operation.

We will use the `SparseArpackSolver` class to illustrate the usage of reverse communication. Figure 2.11 shows part of the pseudo-code for the implementation of `solve()` method in the `SparseArpackSolver` class. The `pfsfct()` and `pfsolv()` functions are provided by the SymSparse solver to solve linear equations, and the

`myMv()` is a subroutine performing matrix-vector multiplication. The `dsaupd()` and `dseupd()` are ARPACK subroutines to compute approximations to a few eigenpairs. For the main loop shown in Figure 2.11, different matrix-dependent operation is taken with different flag (`ido`) value, which is a control indicator generated by ARPACK subroutine `dsaupd()`. By setting the value of this flag, ARPACK tells the client code the required operation or the status of the analysis. After the main loop returns and no fatal errors have occurred, the `dseupd()` is invoked to obtain the eigenvalues and the corresponding eigenvectors if desired. The `dseupd()` method performs eigenvector purification, which is a process to recover eigenvectors when the M matrix is ill-conditioned.

Besides ARPACK routines, a Lanczos eigensolver is also integrated with OpenSees. The implementation of the Lanczos eigensolver mainly follows the spectral transformation Lanczos method developed by Ericsson and Ruhe [29], the Lanczos vector reorthogonalization scheme proposed by Grimes et al. [45], and some refinements developed by Mackay et al. [70]. The linking with the Lanczos eigensolver takes the same strategy as incorporating ARPACK. The `solve()` method of the `LanczosSolver` class uses a similar reverse communication loop as the one shown in Figure 2.11.

2.4 Quality and Performance Measurements

We evaluated the quality and performance of the software components presented in this chapter. We conducted analyses on a number of structural models. All the experiments were performed on a Sun Ultra60 workstation with 256Mbytes of memory and two 450MHz Sun UltraSPARC processors. All the time measurements are wall clock time and are expressed in seconds.

```

// call a routine to factor the matrix (A-sigma*M).
factor = pfsfct(n, diag, penv, nblks, xblk, begblk, first, rowblks);

while (true) {
  // repeatedly call the routine DSAUPD from ARPACK and take
  // corresponding actions indicated by flag ido.
  dsaupd_(&ido, &bmat, &n, which, &nev, &tol, resid, &ncv, v, &ldv,
          iparam, ipntr, workd, workl, &lworkl, &info);

  if (ido == -1) {
    // perform y <-- M*x
    // perform y <-- inv[A-sigma*M]*M*x.
    // pfsslv() is a routine for solving linear equations.
    //   x = workd[ipntr[0]-1]
    //   y = workd[ipntr[1]-1]
    myMv(n, &workd[ipntr[0]-1], &workd[ipntr[1]-1]);
    pfsslv(n, diag, penv, nblks, xblk, &workd[ipntr[1]-1], begblk);
    continue;
  } else if (ido == 1) {
    // perform y <-- inv[A-sigma*M]*M*x
    //   M*x = workd[ipntr[2]-1]
    //   y = workd[ipntr[1]-1]
    myCopy(n, &workd[ipntr[2]-1], &workd[ipntr[1]-1]);
    pfsslv(n, diag, penv, nblks, xblk, &workd[ipntr[1]-1], begblk);
    continue;
  } else if (ido == 2) {
    // perform y <-- M*x
    //   x = workd[ipntr[0]-1]
    //   y = workd[ipntr[1]-1]
    myMv(n, &workd[ipntr[0]-1], &workd[ipntr[1]-1]);
    continue;
  }
  break;
}

// if no fatal errors occur, use DSEUPD for post-processing
// requested eigenvectors may be computed and extracted.
dseupd_(&rvec, &howmy, select, d, v, &ldv, &sigma, &bmat, &n,
        which, &nev, &tol, resid, &ncv, v, &ldv, iparam,
        ipntr, workd, workl, &lworkl, &info);

```

Figure 2.11: Linking ARPACK Through Reverse Communication Interface

2.4.1 Comparison of Matrix Ordering Schemes

Various ordering schemes, including Reverse Cuthill-McKee (RCM), minimum degree ordering (MinD), and generalized nested dissection (GenND), have been implemented in the SymSparse linear solver and integrated with OpenSees through the SymSparse. After METIS has been integrated with SymSparse solver, the METIS ordering routine, which uses multilevel nested dissection (MultiND) algorithm, is also introduced to OpenSees. To evaluate the effectiveness of different ordering schemes, we can compare the size of the matrix factor after the ordering routine is applied. A good ordering is the one that results in the smaller number of nonzero entries in the matrix factor, and fewer nonzero entries usually require fewer numerical operations.

We have used ten finite element models for the experiments. These example models can be categorized into four groups: (1) the brick models (brick10x10x10, brick6x8x50, and brick10x10x20) are three-dimensional beams modeled with eight-node standard brick elements; (2) the Humboldt models (Humboldt1, and Humboldt2) are two-dimensional finite element models for the Humboldt Bay middle channel bridge, which is modeled with quadrilateral elements for the foundation soils and beam-column elements for the bridge; (3) the square models (square40, and square100) are two-dimensional square plates modeled by four-node quadrilateral elements; and (4) the plate models (plate100x20, plate200x20, and plate50x50) are two-dimensional plates modeled by four-node elements MITC4 [9]. Table 4.1 summarizes the numbers of nonzero entries in the matrix factor by using different ordering schemes. Figure 2.12 graphically shows the comparisons of the results by using different ordering schemes.

Table 2.1: Number of Nonzero Entries in the Matrix for Different Ordering Schemes

	Model	Neq	MultiND	MinD	GenND	RCM
1	brick10x10x10	3630	805245	966318	1006290	1642245
2	brick6x8x50	9450	2170458	2127843	2774373	2060523
3	brick10x10x20	7260	2084565	2428959	2744325	3442044
4	humboldt1	5206	187126	177895	187126	408851
5	humboldt2	7294	302612	291268	428270	897269
6	40square	3354	151271	185895	168571	355959
7	100square	20394	1294407	1928819	1519895	5423959
8	plate100x20	12516	1552542	1311337	1816373	1746871
9	plate200x20	25116	3262326	2689381	3805151	28871177
10	plate 50x50	15096	2218923	2167669	2586553	4522121

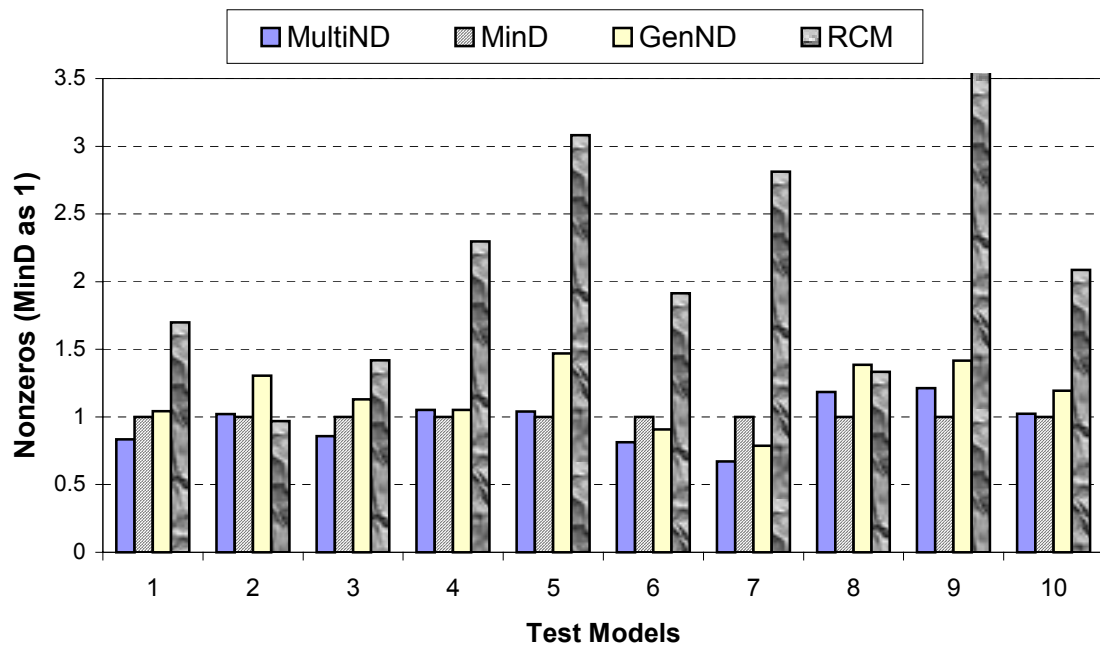

Figure 2.12: Quality Comparison of Different Matrix Ordering Schemes

The heuristic minimum degree ordering is the most widely used fill-reducing algorithm that is applied to the factorization of sparse matrices. The minimum degree ordering has been found to produce very good orderings [41]. As shown in Table 4.1 and Figure 2.12, the quality of the orderings produced by multilevel nested dissection algorithm is comparable to that of the minimum degree ordering. Another observation from the experiments is that the multilevel nested dissection algorithm generates better orderings than the generalized nested dissection ordering. Since the reverse Cuthill-McKee ordering is used to generate orderings for the profile storage of matrices, the number of nonzero entries is often substantially larger than other ordering algorithms.

2.4.2 Performance Comparison of Linear Solvers

The same finite element models used for testing ordering schemes were also used for the performance comparison of different linear solvers. We tested the following linear solvers: SymSparse with multilevel nested dissection ordering (MultiND), SymSparse with minimum degree ordering (MinD), SymSparse with generalized nested dissection ordering (GenND), profile solver (Profile), SuperLU solver (SuperLU), and UMFPAK solver (UmfPack). The solution time for various linear solvers is summarized in Table 2.2 and depicted in Figure 2.13. The solution time is the wall clock time for performing symbolic factorization, numerical factorization, and forward and backward substitutions. The time for assembling element stiffness matrices is not included. The value NA in Table 2.2 indicates that the solution time is substantially larger than using other solvers. The long solution time is primarily due to the large number of page faults. In a paged virtual memory operating system (e.g. Windows, Unix, etc.), a page fault usually occurs when the physical memory is consumed. In this case, an access to a page (block) of memory cannot be mapped to physical memory, thus the operating system has to fetch the page into memory from secondary storage (usually disk). Since accessing disk is much slower than accessing physical memory, page faults can substantially degrade the system performance.

Table 2.2: Solution Time (in Seconds) for Different Linear Solvers

	Matrix	MultiND	MinD	GenND	Profile	SuperLU	UmfPack
1	brick10x10x10	3.82	6.21	5.67	13.9	32.42	52.17
2	brick6x8x50	11.38	11.15	18.53	6.07	20.02	26.79
3	brick10x10x20	13.62	21.17	23.61	25.82	47.15	73.2
4	Humboldt1	0.28	0.26	0.36	1.02	2.28	1.42
5	Humboldt2	0.60	0.78	2.61	5.12	6.51	11.34
6	square40	0.19	0.28	0.22	0.42	0.63	0.91
7	square100	2.51	5.08	3.69	15.82	23.70	34.64
8	plate100x20	4.53	3.49	5.48	56.02	266.28	NA
9	plate200x20	10.21	6.33	12.24	95.81	NA	NA
10	plate 50x50	8.28	8.33	10.63	16.87	72.74	NA

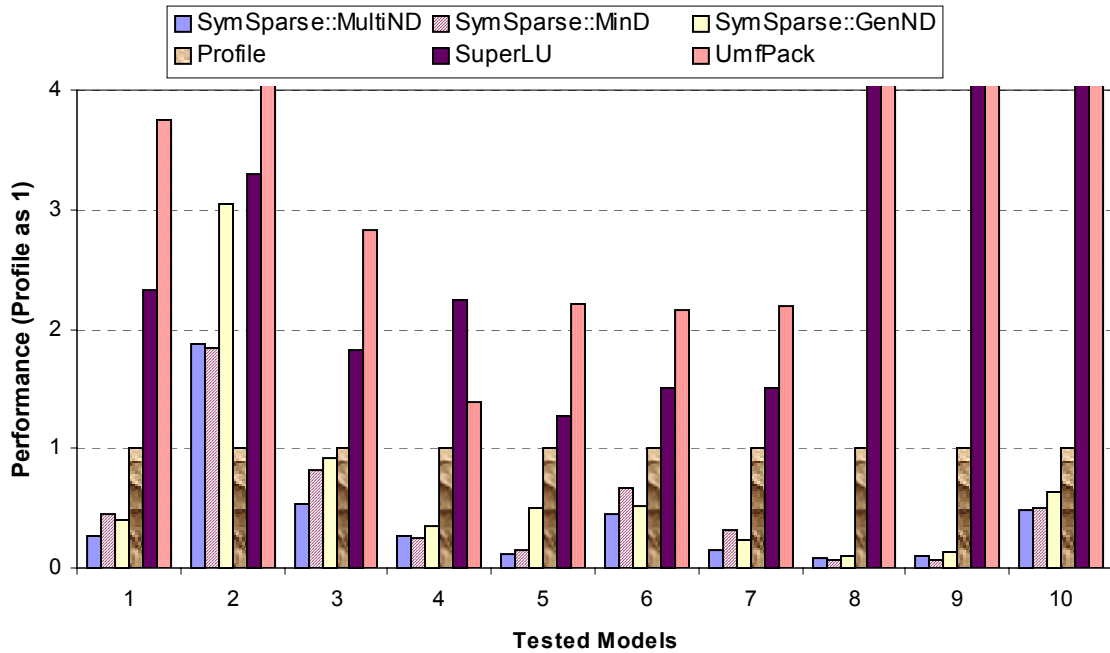

Figure 2.13: Performance Comparison for Different Linear Solvers

The experimental results clearly show that the performance of a linear solver is directly related to the matrix storage requirement. The more nonzero entries in the matrix factor for a linear solver, the more numerical operations are needed for factorization. In this sense, the ordering algorithms and data structures are very important for sparse matrix computation and the solution of linear systems, as they can minimize the matrix storage requirement and facilitate the data element access.

Since finite element programs are usually dealt with symmetric sparse matrices, using general linear solvers are usually not appropriate. The general linear solvers, such as SuperLU and UMFPACK, store both the lower and upper factors. For a symmetric matrix, only the lower or upper factors are needed. Our experimental results clearly showed that specific solvers, such as the SymSparse and profile solver, have better performance than general linear solvers. In terms of choosing ordering schemes, the experimental results showed that both the multilevel nested dissection and the minimum degree ordering are generally better than the RCM and the generalized nested dissection orderings.

The SysmSparse solver outperforms other solvers currently implemented and linked with OpenSees, and the solution time saved by using the SymSparse solver is quite dramatic. The experimental results demonstrated that the system performance could be greatly improved by incorporating the most appropriate software components. Keeping the finite element program core flexible and extendible is very important because it facilitates the integration of software modules.

2.4.3 Comparison of Eigensolvers

We have tested the accuracy of the eigensolvers by performing dynamic analyses. The example finite element model is a two-dimensional 18-story one-bay frame structure. All the beams and columns are modeled as *ElasticBeamColumn* elements and the hinging is modeled with zero-length elasto-plastic rotational element. The first ten smallest eigenvalues of the model are calculated by using both ARPACK and Lanczos eigensolvers. MATLAB is also used to calculate the eigenvalues. To verify the precision of the eigenvalues, the norms of $Kx - \lambda Mx$ are calculated. Table 2.3 summarizes the calculated eigenvalues and their precisions. As demonstrated from the experimental results, both ARPACK and Lanczos solvers are able to produce results with very good precisions.

To compare the performance of ARPACK solver with the Lanczos solver, we have conducted dynamic analyses on another finite element model. The example model is a two-dimensional finite element model for the Humboldt Bay middle channel bridge, which is modeled with quadrilateral elements for the foundation soils and beam-column elements for the bridge. Detailed description of this bridge model will be presented in Section 5.5.2 of Chapter 5. We used the SymSparse linear solver for both the eigensolvers, and the user-specified matrix-vector multiplication $z \leftarrow Mx$ is handled in the element level. Table 2.4 shows the solution time of using both eigensolvers by specifying different number of eigenpairs to be calculated. The experiment results in Table 2.4 demonstrated that the performance of the Lanczos eigensolver is better than the version of ARPACK implemented.

Table 2.3: The Eigenvalues and Their Precisions for Different Eigensolvers

	MATLAB		ARPACK		LANCZOS	
	λ	$n(Kx-\lambda Mx)$	λ	$n(Kx-\lambda Mx)$	λ	$n(Kx-\lambda Mx)$
1	3.036	7.89E-07	3.036	9.26E-08	3.036	9.32E-08
2	18.632	3.44E-07	18.632	1.09E-07	18.632	9.46E-08
3	49.278	4.66E-07	49.278	1.43E-07	49.278	1.04E-07
4	99.838	6.37E-07	99.838	1.19E-07	99.838	9.28E-08
5	176.606	2.33E-06	176.606	1.03E-07	176.606	8.63E-08
6	287.300	6.83E-07	287.300	1.49E-07	287.300	1.04E-07
7	441.317	6.58E-07	441.317	1.24E-07	441.317	1.40E-07
8	649.752	2.31E-06	649.752	1.30E-07	649.752	1.61E-07
9	925.217	3.00E-06	925.217	1.42E-07	925.217	1.51E-07
10	1281.542	7.38E-07	1281.542	2.41E-07	1281.542	8.63E-08

Table 2.4: Performance Comparison Between Lanczos Solver and ARPACK Solver

Number of required Eigenpairs	EigenSolver	Number of used Lanczos vectors	Time (secs)
40	ARPACK	60	25.9
	Lanczos	100	13.18
100	ARPACK	150	80.4
	Lanczos	250	40.72
150	ARPACK	225	151.25
	Lanczos	375	75.33

2.5 Summary

This chapter reviewed the object-oriented program modeling and the fundamental features of object-oriented FEA programs. The main class abstractions adopted in a typical object-oriented FEA program are according to the basic steps involved in a finite element analysis. OpenSees [78] is used as an example to present some important issues in the design and implementation of object-oriented FEA programs. For some important base classes, the class interfaces were presented. It has been pointed out that the flexibility and extendibility were the main design principles and major benefits of object-oriented FEA programs. The flexibility and extendibility of object-oriented FEA programs are partly due to the object-oriented support of abstraction, encapsulation, inheritance, and polymorphism. A sound object-oriented design of FEA program facilitates the integration of external modules, making the integration process to be modular and component-based.

The flexibility of extending object-oriented FEA programs to incorporate new developments and existing modules has been illustrated with several examples. While the technique described can be applied to any object-oriented FEA software program, the discussion and implementation were focused on the OpenSees platform [78]. We used OpenSees as a testing platform to incorporate a new element (eight-node quadrilateral element), a popular graph partitioning and ordering package (METIS [52]), a sparse linear direct solver (SymSparse [69]), and two eigensolvers (ARPACK [59] and Lanczos eigensolver). Because the characteristics of these software components are different, they need to be incorporated via different approaches. The software extending process normally requires introducing one or several subclasses of the existing base classes. In the case of integrating well-defined components, black-box approach can be applied. For some legacy applications, tight integration may be unavoidable because the interfaces of these legacy applications are not well defined. Reverse communication, which is a flexible mechanism to allow users to choose the most appropriate data structures for the

problems, can also be applied to object-oriented FEA programs to facilitate the integration of external components. Although there are a number of approaches to extend the existing object-oriented FEA programs, there is one common feature for all these approaches – the changes to the existing code tend to be localized. The localized code change is very important as it substantially reduces the efforts of integrating components and minimizes the potentials of bugs being introduced.

After the software components are seamlessly integrated with an object-oriented FEA program, the capability and performance of the program can be greatly improved. As shown from the experimental results presented in this chapter, the incorporation of eigensolvers has provided dynamic analyses capabilities to the OpenSees core. The usage of the SymSparse solver can substantially reduce the solution time for solving linear system of equations, which in turn improves the solution of eigenvalue problems and nonlinear structural analyses. Well-defined interfaces and extendable modules are important for the design of object-oriented FEA programs, since these features can facilitate the integration of external components. The incorporating of different types of components allows the user to pick and choose the most appropriate components to solve a finite element problem.

Chapter 3

Open Collaborative Software Framework

This chapter describes an Internet-enabled open software framework that would facilitate the utilization and the collaborative development of structural analysis programs by taking advantage of the Internet, distributed computing, database and other advanced computing technologies [93-95]. A collaborative system is one where multiple users or agents engage in a shared activity, usually from remote locations. By utilizing the Internet as a communication avenue, the framework makes the structural analysis programs more easily accessible to the end users, and also facilitates the integration of new developments. As illustrated in the previous chapter, the ability to easily incorporate new solution algorithms and strategies, especially new sparse solvers and eigensolvers, greatly improves the capabilities and performance of structural analysis programs, making the software platform more efficient for large-scale engineering simulations. In this open collaborative framework, we focus on accessing a software platform and testing and incorporating new developments from a remote site. The framework also adopts a commercial off-the-shelf (COTS) database system, which can address the data management problems encountered by the prevailing file system-based engineering analysis software applications. The Internet-enabled collaborative framework can

potentially provide greater flexibility and extendibility than traditional structural analysis software packages, which are typically packaged individually.

The objective of this chapter is to provide an overview of the framework, its modular design, and the interaction among the modules. The user interaction interfaces are then presented with example usage. Details of core component modules will be described in subsequent chapters. This chapter is organized as follows:

- Section 3.1 gives an overview of the collaborative framework. The architecture and the mechanics of the collaborative framework are described in this section.
- Section 3.2 introduces the modular design of the collaborative framework. The collaborative framework consists of six distinct component modules. The functionality of the component modules and the interaction among them are briefly discussed.
- Section 3.3 describes the user interfaces to the collaborative software framework. The details on two types of user interfaces, namely a web-based interface and a MATLAB-based interface, are presented.
- Section 3.4 presents a simple but typical structural model that will be used as an illustrative example to facilitate the discussion. The sample web-based interface and MATLAB-based interface for analyzing the model are presented.

3.1 Overview of the Collaborative Framework

The collaborative software framework is designed to provide researchers and engineers with easy access to an analysis platform and to incorporate new element technologies, new algorithms, and solution strategies for nonlinear dynamic analyses. Users and engineers can have direct access to the analysis core and the analysis results by using a web-browser or other application programs, such as MATLAB. Researchers and developers can utilize the collaborative framework as a common finite element analysis tool to build, test, and incorporate new developments. A set of Internet-enabled communication protocols is defined to link external new components which can be easily integrated to the collaborative framework through a *plug-and-play* environment.

For the utilization and development of the Internet-enabled collaborative framework, many participants from different organizations are involved. There are end users whose main purpose is to use the core platform as an analysis tool. There are analysts and researchers whose focus is to develop new element and material technologies to enhance the framework. There are also core developers who are working to incorporate new analysis and solution strategies and to expand the analysis core. Since the participants of the collaborative framework play different roles with different perspectives, the focus of the collaborative framework is to support the communication and cooperation of users and researchers, and to facilitate the incorporation of their developments into the framework.

3.1.1 System Architecture

As we discussed earlier, the software framework is designed to support multiple parties and applications and the interaction among these participants. To integrate and link multiple computer applications and parties, a suitable architecture is needed to define how the components (applications or parties) are connected [110]. The proposed

distributed and collaborative system architecture is a versatile, message-based, and modular infrastructure that is intended to improve usability, flexibility, interoperability, and scalability as compared to centralized computing.

The overall system architecture of the Internet-enabled collaborative framework is schematically depicted in Figure 3.1. OpenSees [76] is employed as the finite element software analysis core engine for the prototype implementation of the framework. The architecture defines the dependency and the interaction among the participants.

- In this framework, the structural analysis core program is running on a central server as a compute engine. A compute engine is a remote software program that takes a set of tasks from clients, runs them, and returns the result. Parallel and distributed computing environment can be employed in the central server to improve the system performance and makes it more suitable for large-scale engineering simulations. New analysis strategies and solution strategies can be incorporated to improve the capabilities and performance of the server, as illustrated in the previous chapter for the integration of modules such as the sparse direct solver and the eigensolvers.
- In this collaborative system, users play the role of clients to the central finite element compute engine. The users can have direct or remote access (one such avenue is the Internet) to the core program through a web-based user interface or other application programs, such as MATLAB. The users can specify desirable features and methods (element types, efficient solution methods, and analysis strategies) that have been developed, tested, and contributed to the framework by other participants.
- For element developers, a standard interface/wrapper is defined for communicating the element(s) with the analysis core. The element code can be written in languages such as Fortran, C, C++ and/or Java as long as it conforms to the standard interface, which is a set of pre-defined protocols to bridge the element code with the central server. If the developer and the system administrator agree, the new element can be merged into the analysis core and become part of the static element library.

Moreover, the developer can also choose to be an online element service provider. In this case, the element developer needs to register the element code and its location to the core, and the element service can then be accessed remotely over the Internet. Details of the remote element services will be shown in Chapter 4.

- A COTS database system is linked with the central server to provide the persistent storage of selected analysis results. A customized interface to link the OpenSees core with the database system is implemented. Project management and version control capabilities are also provided for the system. The users can query the core server for useful analysis results, and the data retrieved from the database through the core server is returned to the users in a standard format. The data management will be discussed in Chapter 5.

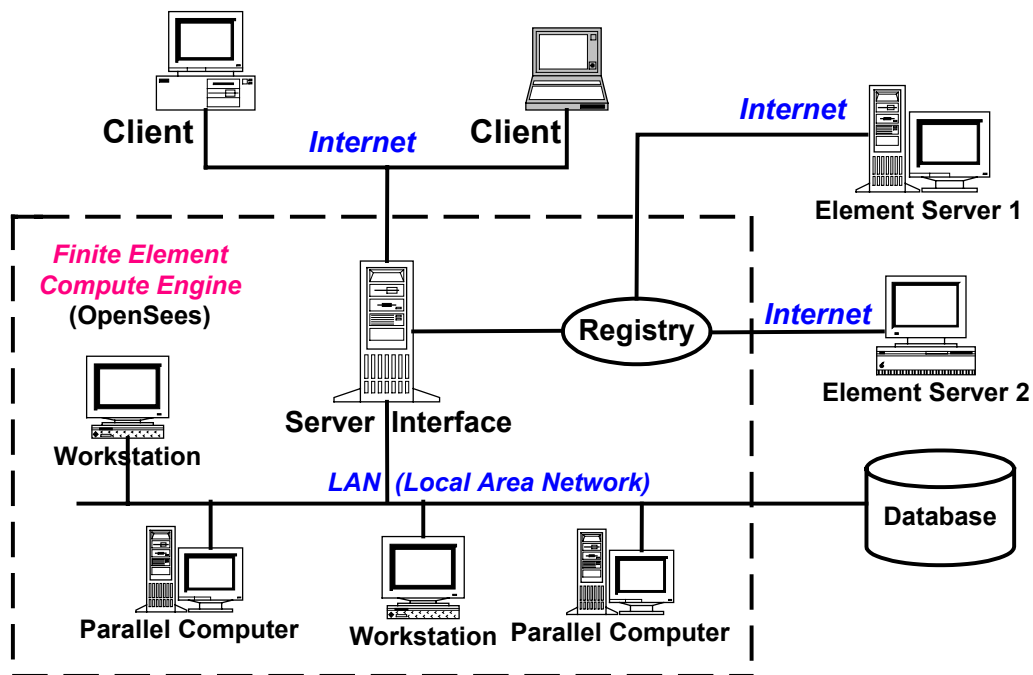

Figure 3.1: The Collaborative System Architecture

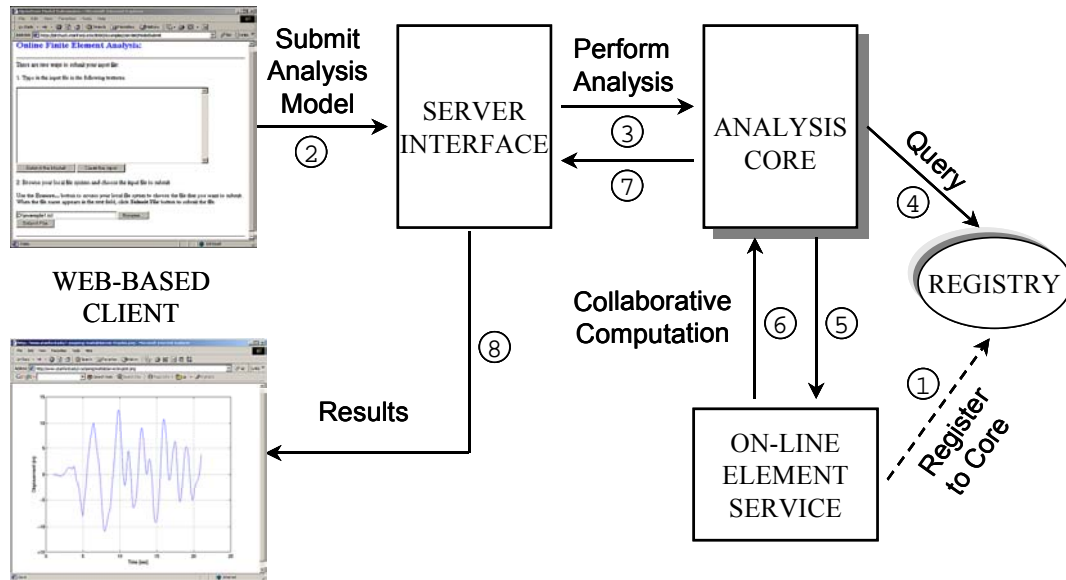

Figure 3.2: The Mechanics of the Collaborative Framework

3.1.2 Mechanics

The mechanics of the open collaborative model is illustrated in Figure 3.2, which shows the essential procedures to access the finite element compute engine and to perform structural analyses over the Internet. First, a user of the system builds a structural model on the client site and then submits it to the analysis core via a web-browser or an application program, using the Internet as a communication channel. Upon receiving the model and other related information, the core server authenticates the user's identity and starts performing a structural analysis based on the received model. Depending on the underlying hardware and system of the server core, the analysis may be performed in a distributed and collaborative manner. During the analysis, elements that are available in the core can be accessed locally from the static element library (this is the case for most prevailing finite element packages), whereas other elements are obtained from online element services. In order to find the required elements not existing in the local element

library, the registry is queried to find the location of the online element services, which have been previously registered to the core platform. Once the online element services have been identified and bound, the analysis core can access these element services in the same way as they are located locally within the core. After the analysis is completed, part of the results will be returned to the user by generating a dynamic web page displayed in the user's web browser.

The user can also query and view the analysis results using a web browser. The process of analysis result query (post-processing) follows almost the same procedures as performing an analysis. Instead of submitting a structural model, the user submits a query to the server platform. The core platform answers the query by returning certain results to the user, and this process may involve database query and certain re-computation.

This section describes the use of a web browser for user interface to illustrate the mechanics of the collaborative system. Besides the illustrated web-based interface, the user can also interact with the core platform by using other application programs, such as MATLAB.

3.1.3 Modular Design

The open collaborative design is focused on systems where complex groupings of components interacting in diverse ways, and in which introducing components would result in lower cost (e.g. due to lower maintenance costs) as well as giving the system a *plug-and-play* character [15]. Generally speaking, a component can be viewed as a black-box entity that provides and/or requires a set of services (via interfaces) [99]. For a finite element program, element code can be treated as a component. Since there are continuing new developments in element technologies, building an element as a separate component can facilitate the concurrent development and the eventual incorporation of the new element into the core. In the prototype framework, a database is used for

efficient data storage and flexible post-processing. Since the database module is loosely coupled with the core program, it is also a good candidate for building as a component. As presented in Figure 3.3, the Internet-enabled structural analysis platform consists of six distinct modules:

- The **Analysis Core** module is the part that consists of a set of basic functional units of a finite element structural analysis program. Element and material models, solvers, as well as analysis strategies and solution strategies, are brought into this module to improve the functionality of the core.
- The **User-Interaction Interface** module provides an interface to facilitate the access to the software platform for the users and developers. The platform can be accessed from either a web-based interface or other application programs.
- The **Registration and Naming Service** is provided for online application services to register to the core so that these services can be found and accessed during analysis. The users can obtain references to certain online application services by querying the Registration and Naming Service.
- Two approaches are provided for remote access to element services residing in different locations. The **Distributed Element Service** is intended to provide a communication link to remote element services where the element code is executed. The **Dynamic Linked Element Service** is implemented to load the element code, which is built as a dynamic shared library, from a remote element service site and to link and bind the code with the core at runtime.
- The **Database Interface** module is built to link with a COTS database, which can provide efficient data access and to facilitate post-processing tasks. Project management and version control are also supported by the data management system.

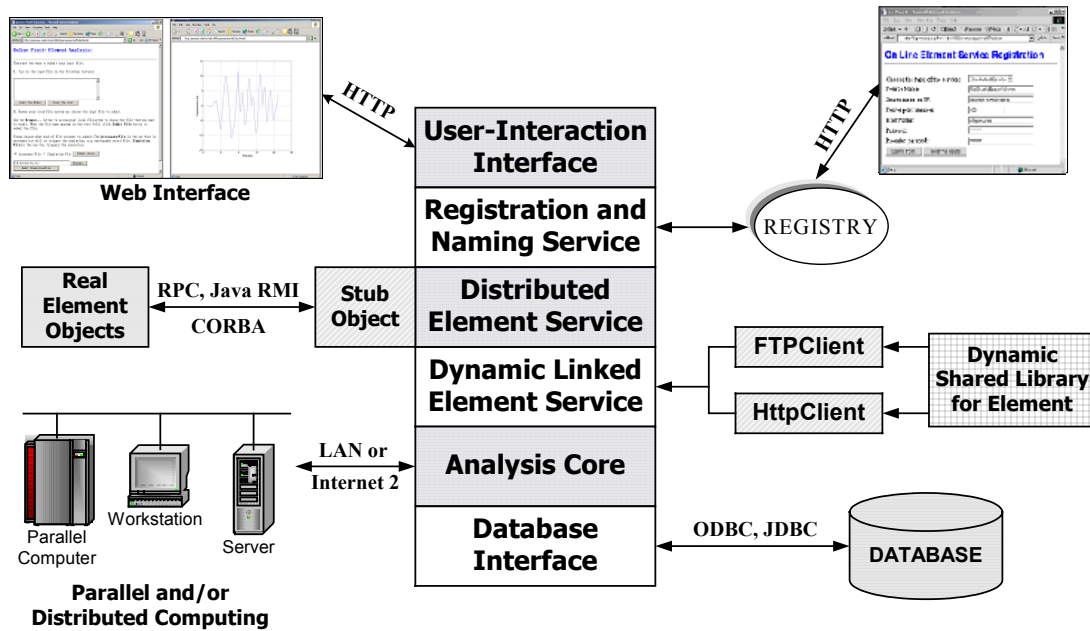

Figure 3.3: The Modules of the Collaborative System

3.2 User Interfaces

As shown in Figure 3.1, the collaborative framework can offer users access to the analysis core, as well as the associated supporting services via the Internet. This client/server computing environment consists of two logical parts: a server that provides services and a client that requests services from the server. Together, the two parts form a complete computing framework with a very distinct division of responsibility [60]. One benefit of this model is the transparency of software services. From a user's perspective, the user deals with a single service from a single point of contact – even though the actual structural analysis may be performed in a distributed and collaborative manner. The other benefit is that this framework can widen the reach of the analysis core to the users and external developers. The core platform offering the finite element analysis service stays at the provider's site, where the software core is developed, kept

securely, operated, maintained and updated. Users can easily access the software platform without the associated cost and maintenance challenges.

In the collaborative framework, the server core is based on a finite element analysis program and a server interface is built to provide the network communication and data wrapping. Java Servlet [50] technology is employed to implement the server interface, which serves as the wrapper to the OpenSees core. For the client application, COTS software packages would be preferred as the user interface. There are two reasons for favoring COTS software packages as user interfaces than developing a new GUI. First, COTS software packages generally provide a friendly and easy-to-use interface to the users. For the popular and widely used software packages, the users are familiar with their interfaces. Furthermore, many COTS software packages normally have built-in facilities for developers to customize them. This makes the development process more economical in terms of development time and efforts. In the current collaborative framework, two types of user interfaces are provided: one is web-based and the other is MATLAB-based.

3.2.1 OpenSees Tcl Input Interface

Since OpenSees is employed as the analysis core for the prototype implementation of the collaborative framework, a brief review is given in the following for the input features of OpenSees. However, the input features of OpenSees are not crucial to the building of the web-based and MATLAB-based interfaces.

In order to conduct an analysis using the current version of OpenSees, most users need to set up an input file. The input file can be parsed and interpreted by the OpenSees interpreter, which is based on an extension of the scripting language Tcl (Tool Command Language) [91]. Tcl is a string based procedural command language that supports substitution, loops, mathematical expressions, and procedures. Besides defining a programmable language, Tcl also has a library package. First, Tcl is a simple textual

language, intended primarily for issuing commands to interactive programs such as text editors, debuggers, and shells. It has a simple syntax and is also programmable, so users can write command procedures to provide more powerful commands than those in the built-in set. Second, Tcl is a library package that can be embedded in application programs. The Tcl library consists of a parser for the Tcl language, routines to implement the Tcl built-in commands, and procedures that allow each application to extend Tcl with additional commands specific to that application. The application program generates Tcl commands and passes them to the Tcl parser for execution. When the Tcl library receives commands it parses them into component fields and executes built-in commands directly. For commands implemented by the application, Tcl calls back to the application to execute the commands.

For the implementation of the OpenSees interpreter, a Tcl library package is embedded in OpenSees. The OpenSees interpreter adds commands to the standard Tcl for finite element analysis. The OpenSees interpreter comprises a set of commands to create finite element models, to specify an analysis procedure, to perform the analysis, and to output the results. Each of these commands is associated (bound) with an OpenSees procedure or class. Thus the users can use these commands to create an OpenSees object and invoke methods on that object. Most of the classes in OpenSees have their corresponding Tcl commands, and the details of these Tcl commands have been described by McKenna and Fenves [77].

Based on the defined Tcl commands, an input file can be created. A typical input file is composed of a sequence of Tcl commands that controls the flow of a finite element analysis. After the input file is submitted to the OpenSees interpreter, the commands in the file are parsed and interpreted, and corresponding methods are invoked on OpenSees to execute the commands. For example, once the interpreter receives the command `element`, it forwards the parameters of the command to OpenSees and informs OpenSees to create an element object with the properties defined by the input parameters.

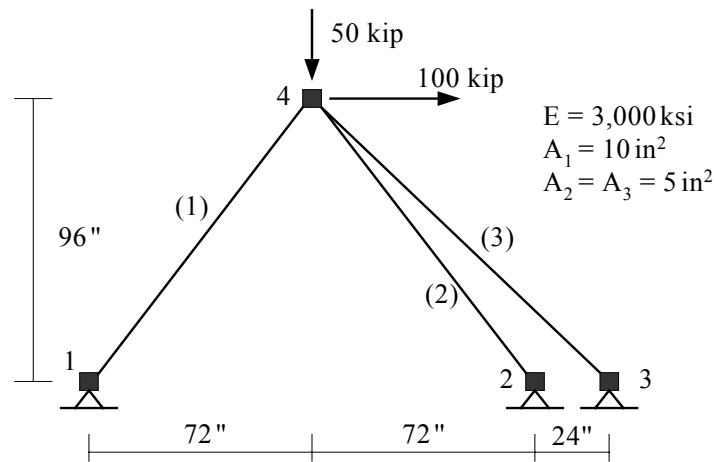

Figure 3.4: The Three-Truss Example (from [77])

To illustrate the usage of Tcl input interface, a simple linear-elastic three bar truss structure is employed. A sketch of the model is shown in Figure 3.4, which consists of four nodes, three truss elements, nodal loads acting at node number 4, and fixed constraints at the three supporting nodes.

The Tcl script for the three-truss example is illustrated as the following. To conduct a finite element analysis on the model, the first step is defining the type of model to be constructed. In this example, a BasicBuilder object is created for a two-dimensional problem with two degree-of-freedom at each node. The BasicBuilder is a subclass of the ModelBuilder class.

```
# Create ModelBuilder (with two-dimensions and 2 DOF/node)
model BasicBuilder -ndm 2 -ndf 2
```

After defining a ModelBuilder for the example, the next step is to construct the model. The model can be constructed by creating all the domain components, which include four Node objects, three Constraint objects, a Material object, three Element objects, and a LoadCase that containing a single NodalLoad object.

```
# Create nodes - node nodeId xCrd yCrd
node 1 0.0 0.0
node 2 144.0 0.0
node 3 168.0 0.0
node 4 72.0 96.0

# Set the boundary conditions - fix nodeID xResrnt? yRestrnt?
fix 1 1 1
fix 2 1 1
fix 3 1 1

# Define material type
uniaxialMaterial Elastic 1 3000

# Create truss elements
element truss 1 1 4 10.0 1
element truss 2 2 4 5.0 1
element truss 3 3 4 5.0 1

# Create a Plain load pattern
pattern Plain 1 "Linear" {
    load 4 100 -50
}
```

After the domain component objects have been created, they are added to the Domain object. At this stage, the types of analysis strategies and solution strategies need to be specified. As we discussed earlier, an Analysis object in OpenSees is an aggregation of several other types of objects. In order to construct an Analysis object, all the analysis component objects need to be created *a priori*. In this example, the component objects include a SparseSPD (linear system of equations and a SymSparse solver), a ConstraintHandler (which deals with homogeneous single point constraints), an Integrator (which is of type LoadControl with a load step increment of one), and an Algorithm (which is of type Linear). Once these objects have been created, the Analysis object can be constructed to set up the links among these objects.

```
# Create the system of equation, a SPD using a band storage scheme
system SparseSPD
constraints Plain
integrator LoadControl 1.0 1 1.0 1.0
algorithm Linear

# create the analysis object
analysis Static
```

At this point, we may define Recorder objects to record the output results during the analysis. In this example, a NodeRecorder is created to record the load factor and the two nodal displacements at Node 4. The last portion of the input file is the command that informs OpenSees to start performing the analysis.

```
# create a Recorder object for the nodal displacements at node 4
recorder Node example.out disp -load -nodes 4 -dof 1 2

# Perform the analysis
analyze 1
```

3.2.2 Web-Based User Interface

Client browser programs such as the Internet Explorer and Netscape Navigator allow users to navigate and access data across machine boundaries. Web browser programs can access certain contents from the web servers via HTTP (hypertext transfer protocol). The forms in the browsers can provide interactive capabilities and make dynamic content generation possible. Java effectively takes the presentation capabilities at the browser beyond simple document display and provides animation and more complex interactions.

For the collaborative system, a standard World Wide Web browser is employed to provide the user interaction with the core server. Although the use of a web browser is not mandatory for the functionalities of the collaborative framework, using a standard browser interface leverages the most widely available Internet environment, as well as being a convenient means of quick prototyping.

3.2.2.1 Web-to-OpenSees Interaction

In order for the server to process the HTTP requests from the client, Apache Tomcat 4.0 [44], which is built on Java Servlet based technologies, is employed as the entry point of server's process. Java Servlets are designed to extend and to enhance web servers. Servlets provide a component-based, platform-independent method for building web-

based application, without the performance limitations of CGI (Common Gateway Interface) programs. Servlets have access to the entire family of Java APIs (application programming interface), including the JDBC API to access COTS databases. Thus Servlets have all the benefits of the mature Java language, including portability, performance, reusability, and crash recovery.

The architecture of the collaborative system with web-based interface is depicted in Figure 3.5, which shows the interaction between the web browser and OpenSees. Apache Tomcat is customized to serve as the Servlet server, which is a middleware to enable the virtual link between the web browser and OpenSees. Since Servlets have built-in supports for web applications, the communication between the web browser and the Servlet server follows the HTTP protocol standards, which is a fairly straightforward process. However, the interaction between the Servlet server and OpenSees may cause some inconvenience because OpenSees is a C++ application and the Servlet server is Java-based. For the database access, OpenSees utilizes ODBC (Open Database Connectivity) to connect the database, and the Servlet server uses JDBC (Java Database Connectivity) to connect the database. The details of database integration and usage will be presented in Chapter 5.

The user of the collaborative system can build a structural analysis model on the client site and then submit the analysis model to the server through the provided web interface. Whenever Apache Tomcat receives a request for an analysis, it will start a new process to run OpenSees. The Servlet server monitors the progress of the simulation and informs the user periodically. After the analysis is complete, some pre-requested (defined and specified in the input Tcl file) analysis results are returned from OpenSees to Tomcat. The Servlet server then packages the results in a properly generated web page and sends the web page back to the user's web browser. One feature of this model is that Java Servlet supports multithreading, so that several users can send requests for analysis simultaneously and the server is still able to handle them without severe performance degradation.

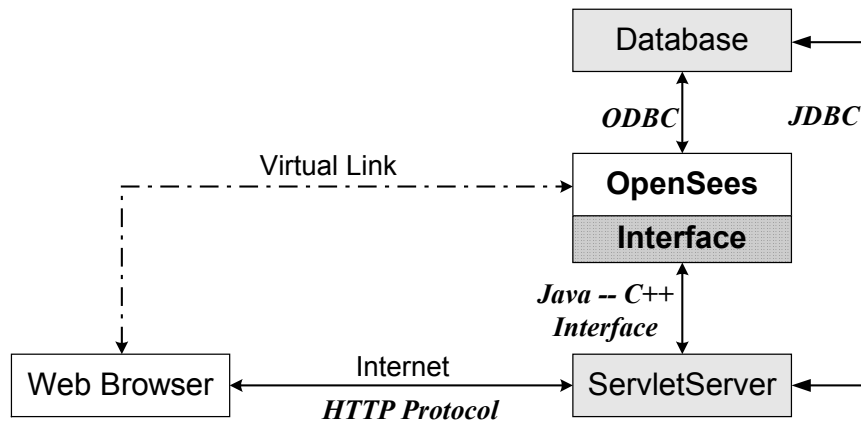

Figure 3.5: The Interaction Diagram for the Web-Based Interface

3.2.2.2 Servlet Server-to-OpenSees Interaction

As we mentioned earlier, the communication between OpenSees (a C++ application) and the Servlet server (implemented in Java) takes more effort to construct. This is because of the intrinsic complexity of integrating Java and C++ applications. There are currently three common mechanisms to integrate Java with C++:

- **External process:** Every Java application has a single instance of class **Runtime** that allows the Java application to interface with an external process in which a C++ application can be running. This is the most straightforward way for a Java application to interact with a stand-alone application written in other languages. The Java API provides methods for performing input from the process, performing output to the process, waiting for the process to complete, checking the exit status of the process, and destroying the process.
- **JNI:** The Java Native Interface [61] is the native programming interface for Java that allows Java code running within a Java Virtual Machine (VM) to operate with applications and libraries written in other languages, such as C, C++, Fortran, or

assembly. In addition, the *Invocation API* allows the embedding of a Java Virtual Machine into native applications. The JNI framework supports native objects to utilize Java objects in the same way that Java code uses these objects. Thus, both the application written in native languages and Java application can create, update, and access Java objects and then share these objects between them.

- **Sockets:** For each network communication pair, the source and destination processes can be uniquely identified by their IP addresses and port numbers. The combination of an IP address and a port number is called a socket. Both Java and C++ have socket classes to construct communication with external processes, which can be on the same computer or on a different computer that connected with some sort of networks. The integration between Java and C++ applications can be achieved by utilizing socket classes to build a communication channel.

All the three modes of integrating Java and C++ applications are utilized in the collaborative framework because each of them has certain advantages and can be applied in different situation. The **External Process** method is the easiest to implement and is relatively robust, but the communication between Java and external process is limited to standard Input/Output. This mode is applied for the Servlet server to invoke an OpenSees process and to submit an analysis model to OpenSees. The **JNI** framework provides fairly complete, but tightly-coupled, connection between Java and external processes. The distributed element service relies on the support of JNI and the details of distributed element service will be explained in Chapter 4. The **Sockets** connection has a clear distinction between source and destination, and thus it helps to keep the connection between Java and C++ applications clear and loosely-coupled.

For a typical structural analysis software package, the user interface needs to support at least two types of operations. One is invoking the analysis and the other is post-processing, which is mainly dealing with analysis results query. The collaborative framework can also provide these two types of operations. For invoking an OpenSees process and transferring the analysis model, the Servlet server utilizes the **External**

Process mode to communication with OpenSees core. For the support of post-processing, the Servlet server exchanges data with OpenSees via a **Socket** connection.

3.2.3 MATLAB-Based User Interface

For web-based services, all too often analysis result is downloaded from the computational server as a file, and then put manually (cut and paste plus maybe some cumbersome conversions) into another program, e.g. a spreadsheet, to perform post processing. For example, if we want to plot a time history response from a dynamic analysis, we might have to download the response in a data file and then use MATLAB, Excel, or other software packages to generate the graphical representation. This *ad hoc* manual process might also involve data format conversion and software system configuration. It would be more convenient to directly utilize some popular application software packages to enhance the user interaction with the collaborative system core, eliminating the cumbersome interim manual procedures. In the collaborative system framework, besides the web-based user interface, a MATLAB-based user interface is developed as an alternative and enhancement for the user interaction. The combination of the intuitive MATLAB interface, language, and the built-in math and graphics functions makes MATLAB the preferred platform for scientific computing compared to C, Fortran, and other applications [115].

The client-side MATLAB service is very flexible and very powerful, and it allows customization for the users. In the current implementation, some extra functions are added to the standard MATLAB for handling the network communication and data processing. These functions are sufficient to perform basic finite element analysis together with certain post-processing capabilities. These add-on functions can be directly invoked from either the standard MATLAB prompt or a MATLAB-based GUI (graphical user interface). The add-on functions can be categorized in the following groups:

- `submitfile`, `submitmodel`: Analysis model submission and analysis invocation;
- `dataquery`: Analysis results query;
- `modelplot`, `deformedplot`, `res2Dplot`: Post-processing.

In the prototype system, we chose MATLAB because of its build-in support and its popularity and availability. However, MATLAB is not the only candidate for building an user interface. Similar network communication protocols and data processing tools can be built for other application programs, such as FEA post-processing packages or Excel.

3.2.3.1 Network Communication

As stated previously, Java Servlet-enabled server is employed as the middleware between clients and the OpenSees core. The Servlet server supports protocols that are specified as rules and conventions for communication. Although the protocols are originally defined for web browser-based clients, they are applicable to any software system that *speaks the same language*. To incorporate MATLAB as a client to the collaborative software framework, a wrapper is needed to handle the network communication for MATLAB. The wrapper can be implemented to conform to the defined Servlet server protocols, thus the same Servlet server can interoperate with both web client and MATLAB client. This approach eliminates the modifications to the existing Servlet server.

Figure 3.6 shows the interaction between MATLAB and OpenSees. The server implementation and configuration are the same as those of the server for web-based client. MATLAB and MATLAB-enabled GUI (graphical user interface) interact with the ServletServer through a Java client, which is provided to make the network communication conform to the existing server protocol. The communication channel between the JavaClient and the ServletServer can be any popular network media, preferably the Internet. Through this layered architecture, a virtual link is established between MATLAB and OpenSees.

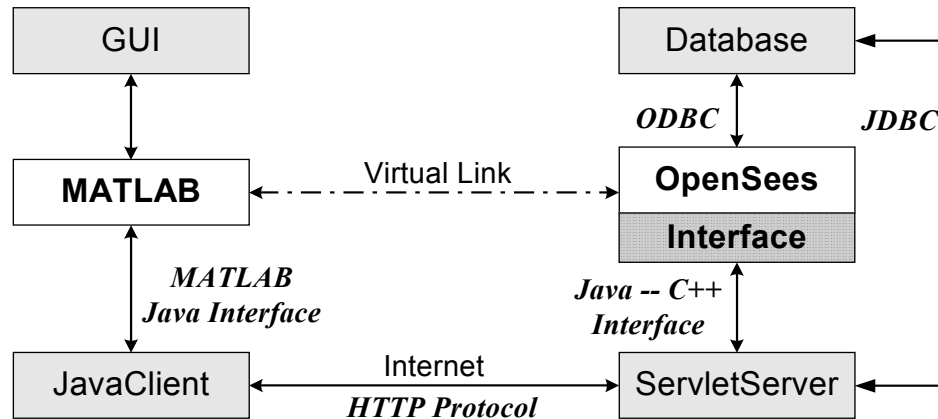

Figure 3.6: The Interaction Diagram for the MATLAB-Based Interface

The link between MATLAB and the JavaClient is supported by the MATLAB Java Interface, which is a new built-in component of MATLAB to interface to Java classes and objects. Every installation of MATLAB includes a Java Virtual Machine (JVM), so that we can use the Java interpreter via MATLAB commands, and we can create and run programs that create and access Java objects. This MATLAB capability enables us to conveniently bring Java classes into the MATLAB environment, to construct objects from those classes, to call methods on the Java objects, and to save Java objects for later reloading – all accomplished with MATLAB functions and commands. More information about the MATLAB Java Interface can be found elsewhere [115].

3.2.3.2 Data Processing

Since a finite element analysis program, such as OpenSees, uses Matrix-type objects (Matrix, Vector, and ID) to represent numerical data, a convenient mechanism is needed to wrap and transmit Matrix-type data. This is handled by using Java arrays. An array in the Java language is strictly a one-dimensional structure because it is measured only in length. To work with a two-dimensional array (a matrix), we can create an equivalent

structure using an array of arrays. Such multilevel arrays are used in the Java programs to represent numerical data. Although Java API class packages provide other types of collections (such as Vector, Set, List, and Map, etc.), the multilevel arrays are chosen to work with MATLAB. This is because multilevel arrays work more naturally with MATLAB, which is a matrix and array-based programming language.

MATLAB makes it easy to work with multilevel Java arrays by treating them like the matrices and multidimensional arrays that are a part of the language itself. We can access elements of an array of arrays using the same MATLAB syntax as if we were handling a matrix. If we were to add more levels to the array, MATLAB would be able to access and operate on the structure as if it were a multidimensional MATLAB's array.

However, the representations of arrays in Java and in MATLAB are different. The left side of Figure 3.7 shows Java arrays of one, two and three dimensions. To the right of each array is the way the same array is represented in MATLAB. In Figure 3.7, a single-dimensional array is represented as a column vector. Java's array indexing is also different from indexing in MATLAB's array. Java's array indices are zero-based, while MATLAB's array indices are one-based. In Java programming, we access the elements of array A of length N using A[0] through A[N-1]. When working with this array in MATLAB, we access the same element using MATLAB indexing style of A(1) through A(N).

The MATLAB `javaArray` function can be used to create a Java array structure that is handled in MATLAB as a single multidimensional array. To create a Java array, we can use the `javaArray` function by specifying the number and size of the array dimensions along with the class of objects. For example, to create a 10 by 5 Java array containing double precision data elements, we can issue the command:

```
A = javaArray('lang.java.Double', 10, 5);
```

Using the one-dimensional Java array as the primary building block, MATLAB then builds an array structure that satisfies the dimensions requested in the `javaArray` command.

Array Access from Java

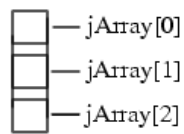

Simple Array

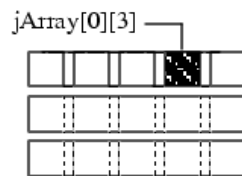

Array of Arrays

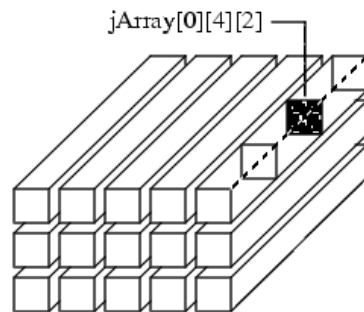

Array of Arrays of Arrays

Array Access from MATLAB

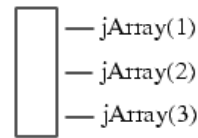

One-dimensional Array

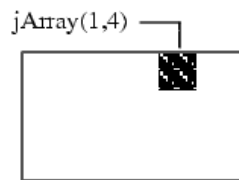

Two-Dimensional Array

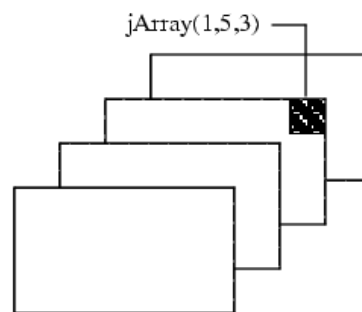

Three-Dimensional Array

Figure 3.7: Array Representations in Java and MATLAB (from [115])

3.3 Example

This section presents a nonlinear dynamic analysis example that will be used to illustrate the usage of the collaborative software framework. The structural model is an 18 story two-dimensional one bay frame. The story heights are all 12 feet and the span is 24 feet. Figure 3.8 shows a sketch of the structural model. As illustrated in the figure, all the beams and columns are modeled as *ElasticBeamColumn* elements and the hinging is modeled with zero-length elasto-plastic rotational element. The model is fine-tuned so that beam hinging occurs simultaneously at the ends of the beams and at the bottom of the first story column. The Tcl input file of the model is partially listed in Figure 3.9.

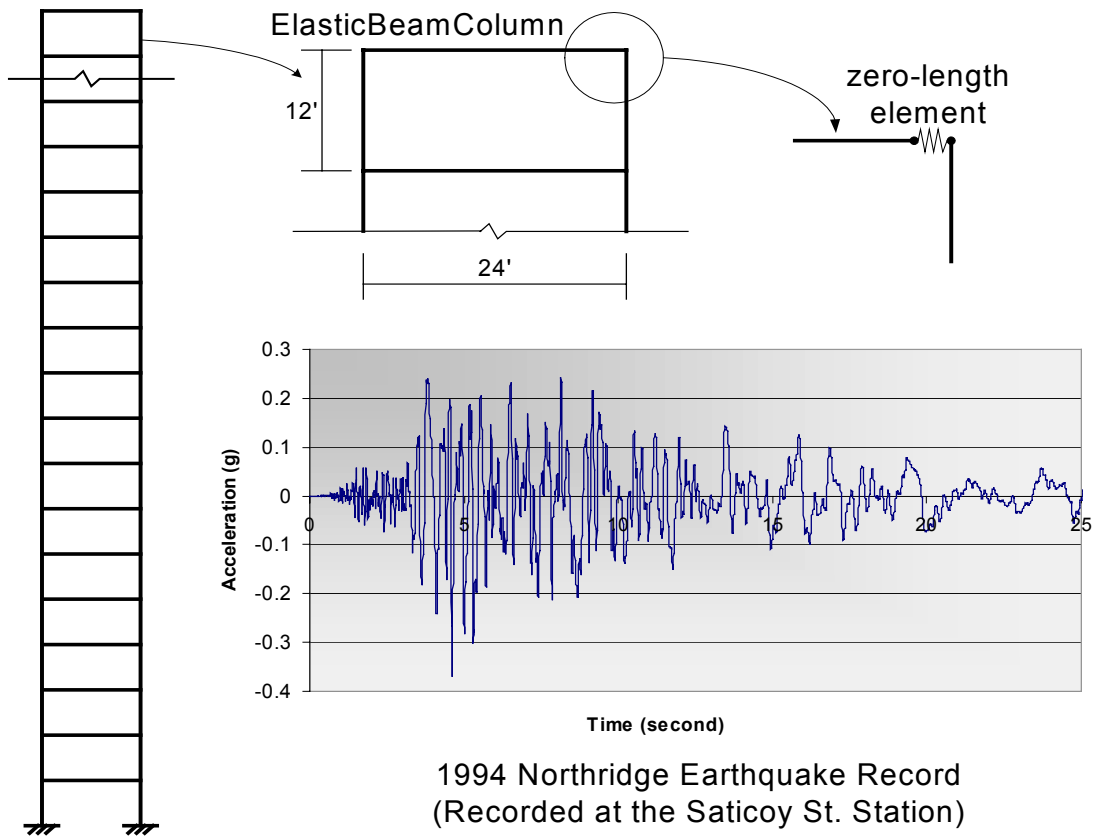

Figure 3.8: The Example Model and the Northridge Earthquake Record

```

# Create ModelBuilder (with two-dimensions and 3 DOF/node)
model basic -ndm 2 -ndf 3

# Create nodes
#   tag      X      Y
node 1      0.0  2592.0  -mass .2589 0.0 0.0
... ..
node 39     0.0  2592.0
... ..
node 75     0.0    0.0
node 76    288.0    0.0

# Fix supports at base of columns (hinged columns)
#   tag  DX  DY  RZ
fix 75  1   1   1
fix 76  1   1   1

# Define moment-rotation relationship for beam springs
#   tag  Ke  rotp
uniaxialMaterial ElasticPP 1  239781.1  0.008674579
... ..

# Define beam-column elements
#   tag ndI ndJ  A  E  Iz  transfTag
element elasticBeamColumn 1 39 40  1e06  2.9e04  396.879  1
element elasticBeamColumn 20 2 4  1e06  2.9e04  396.879  1
... ..

set outfile nr-saticoy
set accelSeries "Path -filePath $outfile -dt 0.01 -factor 1545.6"

pattern UniformExcitation 2 1 -accel $accelSeries
integrator Newmark 0.5 0.25 0.148603 0.0 0.0 0.008512

# Create the system of equation, a symmetric sparse solver
system SparseSPD 3

# Create the constraint handler, the transformation method
constraints Penalty 1e14 1e14

# Convergence test
#   tol  maxIter  printFlag
test NormDispIncr 1.0e-8 20 0

# Create the solution algorithm, a Newton-Raphson algorithm
algorithm Newton

analysis Transient
#   numStep  timeStep
analyze 2000 0.01

```

Figure 3.9: Part of the Tcl Input File for the Example Model

A nonlinear dynamic analysis is performed on the model using Newton-Raphson analysis algorithm. The input earthquake record is from the 1994 Northridge earthquake recorded at the Saticoy St. station, California. A time history plot of the earthquake record is shown in Figure 3.8.

3.3.1 Sample Web-Based Interface

In the web-based user interface, two modes of inputting a Tcl script are accepted. Users can directly submit Tcl command lines to the server; or they can first edit a Tcl script file and then submit the input file to the central server. Figure 3.10(a) shows the web form for the submission of the example Tcl script (listed in Figure 3.9). After the user submits an analysis model, the model is forwarded to OpenSees by the Servlet server. This process will also automatically invoke OpenSees to start the analysis.

During the structural analysis, some selected analysis results are saved in the database or in the server file system to facilitate future post-processing. Some user pre-requested data (specified in the input Tcl script) are returned to the user whenever they are generated by OpenSees. The Servlet server can properly wrap the data in certain format and return the dynamically generated web pages to the user's browser. These data can be used to indicate the progress of the analysis, as shown in Figure 3.10(b).

The web-based user interface also supports post-processing. It allows the user to query the analysis results and to download certain results into files. Figure 3.10(c) shows the web interface for downloading time history response files. Besides transmitting the analysis results in data file format, the server can also automatically generate a graphical representation of the result and send the graph to the user. Figure 3.10(d) shows the graphical representation of the time history response of Node 19, which is the left node on the 9th floor in the structural model. The plotting is performed by a stand-alone MATLAB service that is connected with the collaborative framework. Although the MATLAB service can conveniently take a data file as input and generate a graph file as

output, it is not flexible enough to support customization, i.e. allowing the user to add new functions.

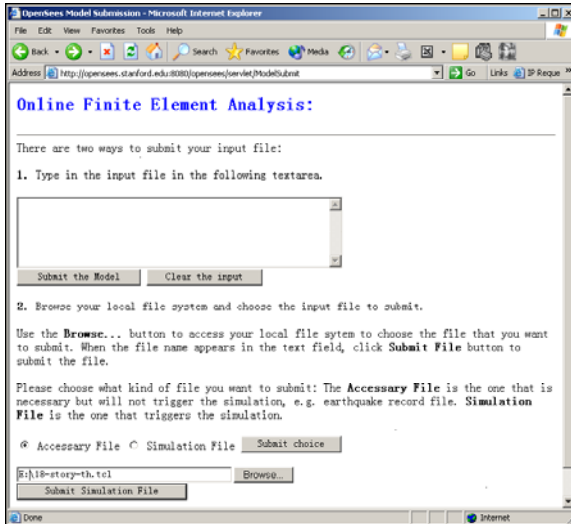

(a) Analysis Model Submission

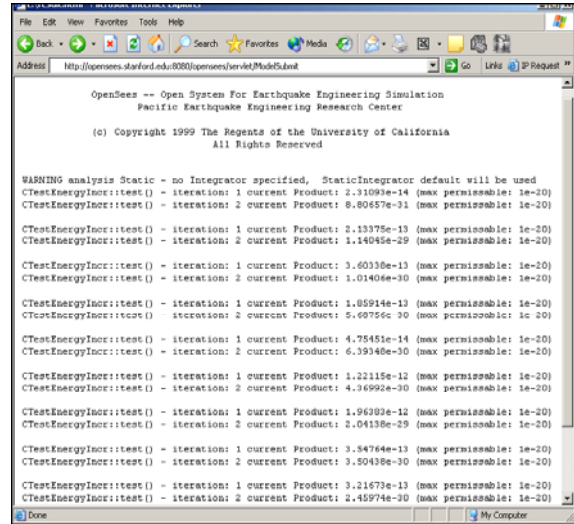

(b) Analysis Progress Report

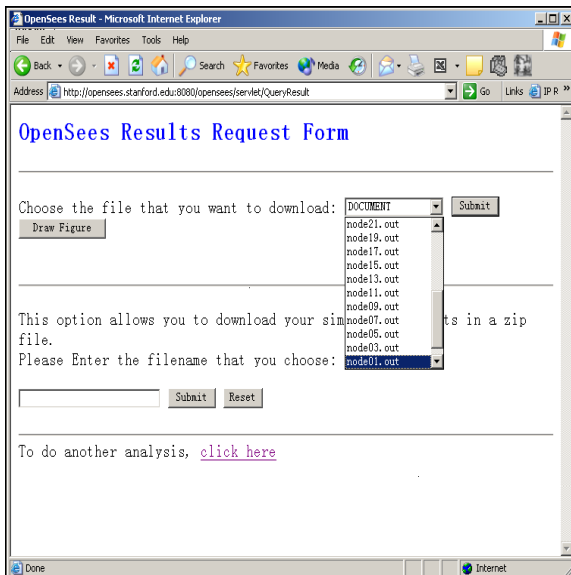

(c) Analysis Result Query

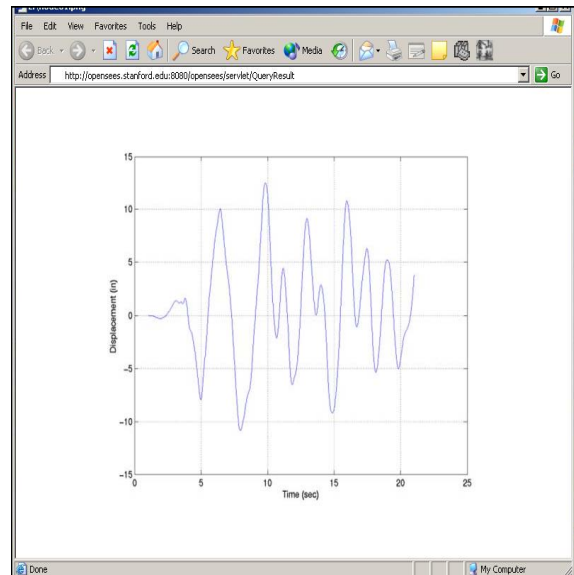

(d) Time History Response of Node 19

Figure 3.10: Sample Web Pages Generated on the Client Site

3.3.2 Sample MATLAB-Based Interface

To perform a nonlinear dynamic analysis on the example model (shown in Figure 3.8) using the MATLAB-based interface, we need to first issue the command: `submitfile nr-saticoy`. The command submits the earthquake record file to the server without invoking OpenSees to conduct an analysis. After the earthquake record is saved on the server, the following command, `submitmodel 18-story-th.tcl`, then can be issued to submit the input Tcl file. Once the server receives the Tcl file, it starts a new process to perform the requested analysis.

After the analysis is complete, `dataquery` command can be issued to bring up an interaction window for the user to query analysis results. For illustration purpose, the following only shows a typical data query session. First, we can use the query command, `RESTORE 550`, to restore the analysis domain state to time step 550. After the domain is initialized to time step 550, we then can issue a query to save the nodal displacement in a file named `disp.out`

```
SELECT node disp FROM node=*  
SAVEAS disp.out;
```

As discussed earlier, some pre-defined commands can be invoked directly to generate graphical representations, taking advantage of mathematical and graphic functions of MATLAB. For instance, the command `modelplot` can be invoked to generate a plot of the model, as shown in Figure 3.11(a). There are two steps involved in this process. The first step is that the MATLAB client automatically contacts the server for the information about nodes and elements. The returned data from the server are saved in two files: `node.out` and `element.out`. Based on these two files, the second step is generating the graph. At this stage, since the client already has information about nodes, elements, and nodal displacement, the deformed model can be plotted. Figure 3.11(b) presents the plot of the deformed shape using the command: `deformedplot(10)`, where 10 is an amplification factor to make the visualization easier.

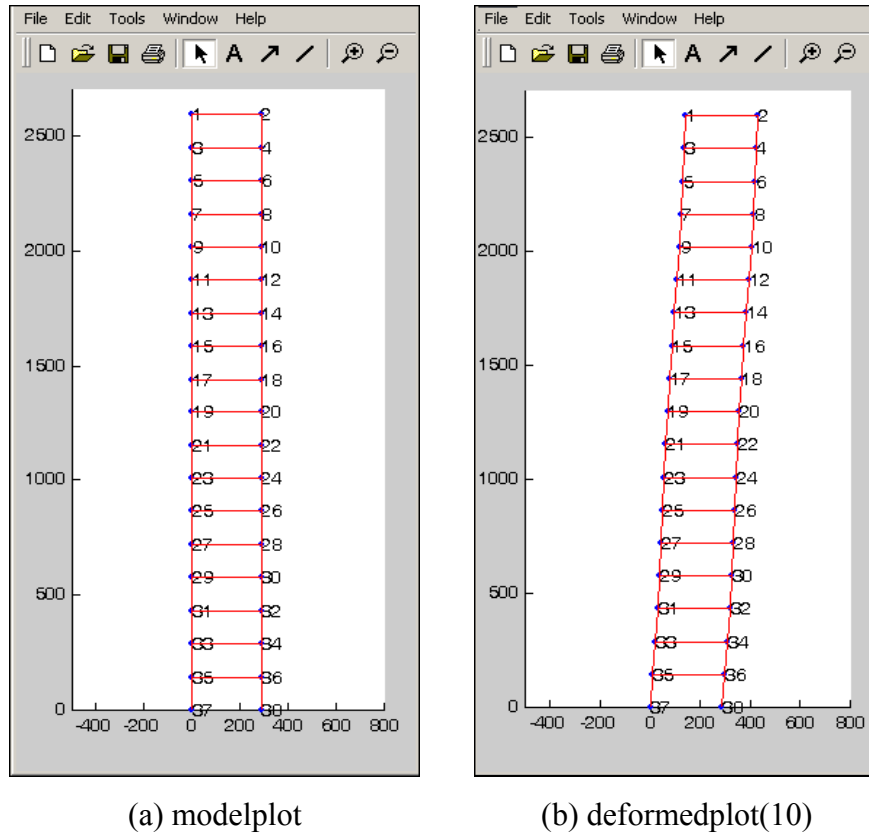

Figure 3.11: Sample MATLAB-Based User Interface

3.4 Summary

This chapter provided an overview of the Internet-enabled open collaborative software framework for engineering analyses and simulations. The framework follows a component-based modular design which allows each component to be designed and implemented independently and still be able to work together. The focus of the open collaborative software framework is to support the communication and cooperation of users and researchers, and to facilitate the incorporation of their research developments into the framework.

The collaborative framework can offer users access to the analysis core, as well as the associated supporting services via the Internet. In the prototype implementation, both web browser and MATLAB are utilized to provide the users with the interactions to the core server. By leveraging the standard and widely used software packages, the interfaces are easier to implement and more familiar for the users.

The Internet-enabled open collaborative engineering software for analysis and simulation has at least three benefits. First, the platform provides a means of distributing services in a modular and systematic way. The modular service model helps the integration of legacy code as one of the modular services in the infrastructure. Users can select appropriate services and can easily replace a service by another one, without having to recompile the existing services being used. Secondly, the client-server nature of the framework makes it possible for the end users to take advantage of the server computing environment, where the distributed and parallel computing environment can be utilized to facilitate large-scale engineering simulations. Finally, the framework alleviates the burden of managing a group of developers and their source code. Once a common communication protocol is defined, participants can develop the code in compliance with the protocol. The need to constantly merge the code written by different participants can be alleviated.

Chapter 4

Internet-Enabled Service Integration and Communication

One of the salient features of the open collaborative software framework is to facilitate analysts to integrate new developments with the core server so that the functionalities of the analysis core can be enhanced. The Internet-enabled collaborative service architecture would allow new application services to be incorporated with the analysis core in a dynamic and distributed manner. A diverse group of users and developers can easily access the platform and contribute their own developments to the central core. By providing a modular infrastructure, services can be added or updated without the recompilation or reinitialization of the existing services. For illustration purpose, this chapter focuses on the model integration of new elements to the analysis core of OpenSees. There are two types of online element services: namely distributed element service and dynamic shared library element service. The infrastructure for supporting the integration of these two types of online element service is presented. Similar infrastructure and communication protocol can be designed and implemented to link other types of online modular services, e.g. material services, solution algorithms services, and analysis strategies services, etc. OpenSees is employed as the finite element analysis core in the prototype implementation.

In order to build an Internet-enabled service framework for an object-oriented FEA program such as OpenSees, a standard interface/wrapper needs to be defined for communicating the online element services with the analysis core. The standard interface can facilitate the concurrent development of new elements, and allow the replacement of an existing element code if a superior one becomes available. The encapsulation and inheritance features of object-oriented programming are utilized to define the standard interface for the element. As discussed in Chapter 2, a super-class *Element* is provided in an object-oriented FEA program kernel (for details about the *Element* class in OpenSees, see [76]), which defines the essential methods that an element needs to support. The traditional way of introducing a new element into the object-oriented FEA program is to create a subclass of the *Element* class and possibly using the new class to encapsulate the code related to the new element. The new element code, once tested and approved for adoption, becomes part of the core's static element library. For the Internet-enabled collaborative framework, the code developer can also choose to be an online element service provider. Two forms of online element services, namely distributed element service and dynamic shared library element service, are introduced in the collaborative framework. Which form of services to be used for linking the element with the core is up to the developers for their convenience and other considerations. As long as the new element conforms to the standard interface, it will be able to communicate with the analysis core. As opposed to the traditional statically linked element library, the online element services will not expose the source code to the core. Therefore, the collaborative platform allows the building of proprietary element services and facilitates the linking of legacy applications.

The online element service can be released to public use by registering itself to the Registration and Naming Service (RANS) with its name, location, service type (whether a distributed service or a dynamic shared library service) and other pertinent information. During a structural analysis, the RANS can be queried to find the appropriate type and location of the requested element service. Although there are three types of element services (static element library and two forms of online element services), the selection

and binding of element services are automatic and completely transparent to the users. The end users do not need to know the type of element service to choose, nor do they need to be aware of the location of the service.

In this chapter, we describe in details the development of an application service and its integration with the Internet-enabled finite element analysis framework. This chapter is organized as follows:

- Section 4.1 describes the registration and naming service (RANS) for the Internet-enabled collaborative framework. The design and the implementation of the RANS server are presented.
- Section 4.2 provides a detailed description of the distributed element service. The mechanics of the distributed element service, the interaction of distributed applications with the analysis core, and the implementation of the distributed element service are presented in this section.
- Section 4.3 describes the dynamic shared library element service. The comparison between static libraries and shared libraries is presented. The mechanics and the implementation of the dynamic shared library element service are also described.
- An example scenario of applying online services to perform structural analysis is presented in Section 4.4. Some potential performance optimization techniques for online element services are discussed in this section.

4.1 Registration And Naming Service

In order to support distributed services with many participants, the core server must be able to differentiate the services and locate appropriate services for specific tasks. One approach to resolve this problem is to create a Registration and Naming Service (RANS), where an agent or participant could register its service to the RANS with a unique service name and address for the service. The RANS allows names to be associated with object references, and would be responsible for mapping the named services to the physical locations. With the RANS, the users can obtain references to the objects (services) they wish to use. Clients may query the RANS to obtain the associated object reference and the description of the service. Figure 4.1 shows a distributed service registering its name and property to the RANS server. Clients can then query the RANS using a predetermined name to obtain the associated distributed service.

The architecture of the RANS server is almost the same as that of the core collaborative framework, which is depicted in Figure 3.5. The RANS is a service located on the central server, the Java Servlet server is employed to handle the user requests, and a COTS database system is utilized to store the persistent information related to registered services. In the prototype system, the RANS is implemented in Java, which allows an application to use JDBC to communicate with the database to store and retrieve data. To differentiate different services, a unique identity (name) is needed to associate with each service. A relational table **ServiceInfo** is defined in the database to store the information related to the registered services. Figure 4.2 shows the schema design of the **ServiceInfo** table. Since the service name is used to identity a service, the name field in the table is declared as primary key, which guarantees the uniqueness of the name and facilitates the queries based on this key.

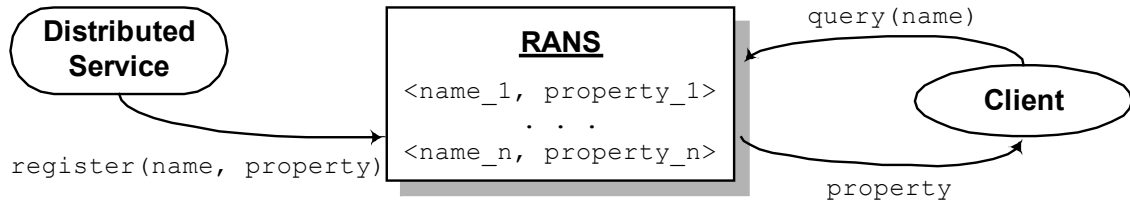

Figure 4.1: Registering and Resolving Names In RANS

```

CREATE TABLE ServiceInfo (
  name      CHAR(31) PRIMARY KEY,
  type     CHAR(31),
  IP       VARCHAR(255),
  port     CHAR(31),
  creator  CHAR(31),
  misc     VARCHAR(255),
  ctime    DATE
);
  
```

Figure 4.2: The Schema of the ServiceInfo Table

In the prototype implementation, a Java class `Identity` is defined to record the service identity. Each service is identified by a *name* property and an *id* property. The string *name* property is a descriptive name that can be used to specify the service. The integer *id* is an internal identifier generated to uniquely tag each service. We have designed the `Identity` class to implement the `Java Serializable` interface, so that `Identity` objects can be passed back and forth on the network as a data stream. One important method of the `Identity` class is `equals()`, which can be used to identify if two identities are the same. Besides the *name* and *id* fields, the `Identity` class also stores other service-related information, for example, the service type, IP address, the port number, and the creator of the service, etc.

```
public class RANS {
    // used for temporarily store Identity objects.
    Hashtable curIdentities = new Hashtable();

    // online service registers to the core.
    String register(String name, String type, String IP,
        int port, String creator);

    // online service updates the information
    String update(String name, String type, String IP,
        int port, String creator);

    // query the information of a service.
    Identity query(String name);
}
```

Figure 4.3: Interface for the RANS Class

The core functionalities of the RANS server is defined in a class named RANS, which is served as a broker for registering and binding services. The class interface of RANS is shown in Figure 4.3. There are three important methods provided by the RANS class:

- `register()` can be invoked by online services to register themselves to the core. This method gathers the data related to a service and sends them to the database. If the name entry is not saved in the database (which indicates that a service with the same name has not been registered yet), a new entry will be inserted into the **ServiceInfo** table. Otherwise, an error message is returned to the invoker of the `register()` method.
- `update()` has the same function signature as `register()`. It is also used to gather and save the service information. However, instead of inserting a new entry into the database **ServiceInfo** table, the `update()` method is invoked to update an existing registered service. If a database entry with the input name does not exist, an error message is returned.

- `query()` is invoked by the analysis core to find the requested services and to bind them. This process may involve a database query; and the queried data is represented as an Identity object, which is returned to the invoker of this method.

In the RANS class implementation, a hash table is used to store the recently queried Identity objects. The hash table serves as a cache for the **ServiceInfo** table. During the process of querying a service, the hash table is first searched to find a matching service. It is only when the service cannot be found in the hash table that the database is queried. In this case, the Identity of the queried service will be saved in the hash table to facilitate further queries. Since most likely a recently used service will be access again, keeping a cache of recently accessed services can potentially improve the performance of the `query()` method.

In the open collaborative framework, after an online element service is developed and tested, the author of the element may release the element for other users. To make the element accessible to others, the first step the developer needs to perform is to register the element service to the RANS server. The registration can be done through a web-based interface, which sends the service information to the Java Servlet server, and in turn invokes certain method of RANS class.

4.2 Distributed Element Services

A key feature of an object-oriented FEA program such as OpenSees is the interchangeability of components and the ability to integrate existing libraries and new components into the analysis core without the need to dramatically change the existing code. Introducing a new type of element into an object-oriented FEA program generally consists of creating a new subclass of Element class. This local object-computing paradigm can be extended to support distributed services. Instead of only using the objects that reside exclusively on the local computer, the collaborative framework also

utilizes distributed (remote) objects, which allows the building of a distributed application to facilitate new element development.

Distributed applications are normally comprised of two separate programs: a server and a client. A typical server application creates some remote objects, makes references to them as accessible, and waits for clients to invoke methods on these remote objects. A typical client application obtains a remote reference to one or more remote objects in the server and then invokes methods on them.

4.2.1 Mechanics

The essential requirements in a distributed object system are the ability to create and invoke objects on a remote host or process, and interact with them as if they were objects within the same local process. To do so, some kind of message protocol is needed for sending requests to remote agents to create new objects, to invoke methods on these objects, and to delete the objects when they are done. Assorted tools and standards for assembling distributed computing applications have been developed over the years. They started as low-level data transmission APIs and protocols, such as TCP/IP and RPC [6] and have recently begun to evolve into object-oriented distribution schemes, such as OpenDoc [68], CORBA [90, 100], DCOM [28], and Java RMI [98]. These programming tools essentially provide a protocol for transmitting structured data (and, in some case, actual running code) over a network connection.

In the prototype implementation, Java's Remote Method Invocation (RMI) is chosen to handle communication for the distributed element services over the Internet. Java RMI enables a program in one Java Virtual Machine (VM) to make method calls on an object located on a remote server machine. RMI allows distributing computational tasks across a networked environment and thus enables a task to be performed on the machine most appropriate for the task [31]. The *skeleton*, which is the object at the server site, receives method invocation requests from the client. The *skeleton* then makes a call to the actual

object implemented on the server. The *stub* is the client's proxy representing the remote object and defines all the interfaces that the remote object supports. The RMI architecture defines how remote objects behave, how and when exceptions can occur, how memory is managed, and how parameters are communicated with remote methods.

There are many fundamental differences between a local Java object and a remote Java object, which are summarized in Table 4.1. Because the physical copy of a remote object is existed in a remote server instead of in the local computer and is accessed by the clients through *stubs*, the behaviors (definition, implementation, creation, and access) of the remote object are different from a regular local object. In Table 4.1, we also compare the references, finalization, and exception handling characteristics between a local object and a remote object. The references are also called *pointers* in certain programming languages. The references are like jumps, which can be used to point to a data structure. If an object is no longer needed by the system, the object becomes a candidate for *finalization*, which is a process that the memory and other computer system resources allocated for the object are reclaimed by the system. Java automatically reclaims memory used by an object when no object variables refer to that object, a process known as *garbage collection*. An *exception* is an abnormal condition that disrupts normal program flow. There are many cases where abnormal conditions happen during program execution, such as the file that the program trying to open may not exist, the network connection may be disrupted, or a number is divided by zero. If these abnormal conditions are not prevented or at least handled properly, either the program will be aborted abruptly or incorrect results or status will be carried on, causing more abnormal conditions. In Java, the exceptions need to be handled to ensure the correctness and robustness of the program.

Table 4.1: The Comparison Between Local and Remote Java Objects

	Local Object	Remote Object
Object Definition	A local object is defined by a class.	A remote object's exported behavior is defined by an interface that extends the Remote interface.
Object Implementation	A local object is implemented by its defined class.	A remote object's behavior is executed by a class that implements the remote interface.
Object Creation	A new instance of a local object is created by the <code>new</code> operator.	A new instance of a remote object is created on the server computer with the <code>new</code> operator. A client cannot directly create a new remote object.
Object Access	A local object is accessed directly via an object reference variable.	A remote object is accessed via an object reference variable which points to a proxy stub implementation of the remote interface.
References	An object reference points directly at an object in the local heap.	A remote reference is a pointer to a proxy stub object in the local heap. That stub contains information that allows it to connect to a remote object, which contains the implementation of the methods.
Finalization	The memory of an object is reclaimed by the garbage collector when there is no reference to the object.	When all remote references to an object have been dropped, the object becomes a candidate for garbage collection.
Exceptions	Exceptions are enforced and handled locally.	RMI forces programs to deal with any possible RemoteException objects that may be thrown. This can ensure the robustness of distributed applications.

The design goal for the RMI architecture is to create a Java distributed object model that integrates naturally into the Java programming language and the local object model. The language features in Java help programmer to write client/server components that can interoperate easily. Besides Java RMI, the Java API has other facilities for building distributed applications. Low-level sockets can be established between agents, and data communication protocols can be layered on top of the socket connection. The object serialization feature of Java allows an object to be converted into a byte stream, and the byte stream can be reassembled back into an identical copy of the original object. Thus, an object in one process can be serialized and transmitted over a network connection to another process on a remote host. APIs built on top of the basic networking support in Java provide higher-level networking capabilities, such as distributed objects, remote connections to database servers, directory services, etc. Java also provides a high level of security and reliability in developing a distributed environment.

Although Java environment is powerful and convenient in building distributed services, there is still one challenge for building distributed element service in the collaborative framework: incorporating legacy systems in the Java infrastructure. The original FEA core system is written in C++, and partly written in C and Fortran (referred to as *native languages* in Java terminology). The core of the distributed element services may also be written in native languages. Thus, a communication support between Java and other languages is needed for building distributed element services. As we discussed in Section 3.2, there are three ways to link Java applications with native methods. Since the communication is tightly coupled in this case, the Java Native Interface (JNI) is utilized. JNI [61] is the native programming interface for Java that allows Java code running within a Java Virtual Machine to operate with applications and libraries written in other languages, such as C, C++, Fortran, or assembly.

The purpose of JNI is shown in Figure 4.4. Both the codes written in the native language and Java can create, update, and access Java objects and then share these objects between them. By programming through the JNI, we can use Java objects to access native

methods and libraries. The JNI framework also supports native objects to utilize Java objects in the same way that Java code uses these objects. For instance, the native methods can create, inspect and update Java objects, and then call Java methods. Furthermore, the native methods can load Java classes and obtain class information. The native methods are even allowed to perform runtime type checking. Details about the mechanics of JNI and how to program JNI can be found in Liang [61].

Figure 4.5 illustrates the mechanics of the distributed element services infrastructure. Within the infrastructure, an element service can be written in any popular programming languages: Java, C, C++, or Fortran. As long as the element service conforms to the defined protocol, the service can participate in the framework. For the distributed element service, the actual element code resides in the service provider's site. For the implementation with OpenSees as the analysis core, the developed element service communicates with the analysis core through a communication layer, which consists of a *stub* and a *skeleton*. A remote method call initiated by the OpenSees core tunnels over the communication channel and invokes certain method on the element service. For example, the OpenSees core issues a remote method invocation to send the input data of an element (e.g. geometry, nodal coordinates, Young's modulus, and Poisson ratio, etc.) to the element service. Later on, when the core needs certain element data, for example a stiffness matrix, the OpenSees core requests the service provider through a sequence of remote method invocations. The computation (e.g. the forming of the stiffness matrix of an element) is performed at the service provider's site and the results are then sent back to the core as the return value of the remote method invocation.

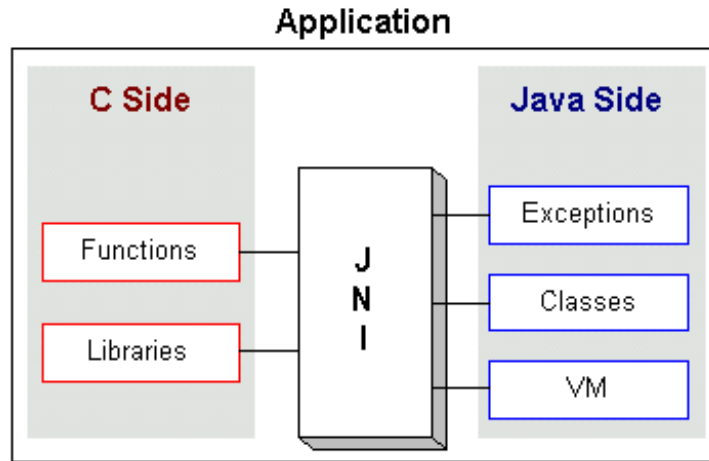

Figure 4.4: The Purpose of JNI (from [112])

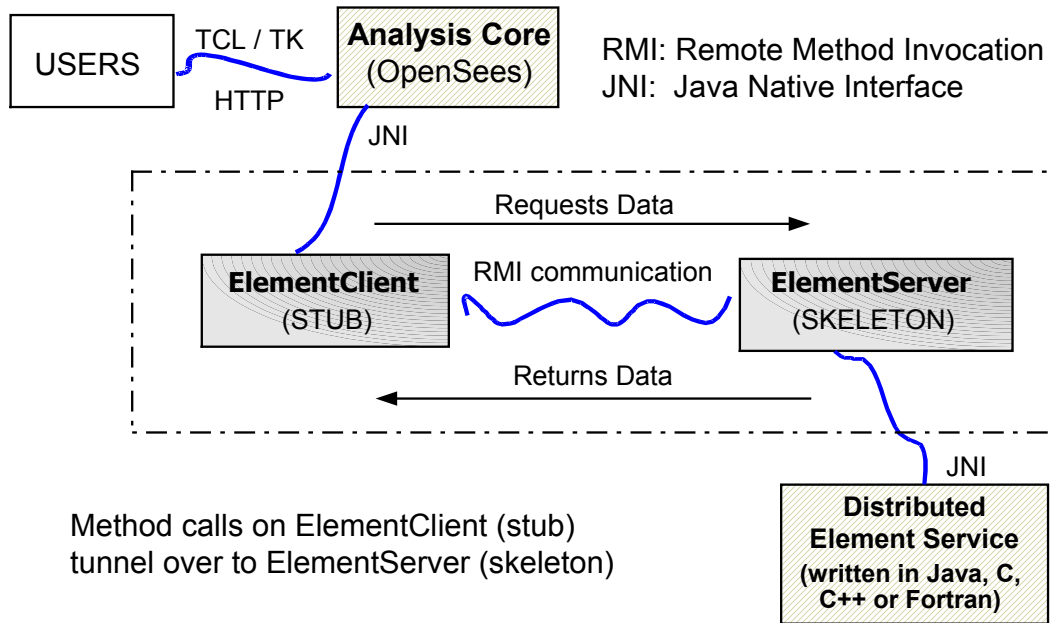

Figure 4.5: The Mechanics of the Distributed Element Service

4.2.2 Interaction with Distributed Services

A typical distributed service conceptually can be viewed as a blackbox – it takes certain inputs and then generates data as outputs. The key item in the distributed service computing is the interface, which defines what types of functions the service supports. A set of interfaces should be fully defined, available to the public, and appropriately maintained. Following the object-oriented paradigm, the “exposed” methods of the interface are the points-of-entry into the distributed services, but the actual implementation of these methods is dependent on the individual service. To standardize the implementation of a new distributed element, we define a common interface named `ElementRemote` in the collaborative framework, as presented in Figure 4.6. Note that the `ElementRemote` interface is almost the same as the standard `Element` interface that is provided by the core OpenSees program (shown in [76]). The difference lies in the following four aspects:

- The `ElementRemote` interface introduces two additional methods that are not defined in the original `Element` interface. One is `formElement()` that is used by the client to send the input data (geometry, nodal coordinates, etc.) to the actual element service. The other is `clearElements()`, which can be called to perform the “house-cleaning” task once the analysis is completed.
- Most methods defined in the `ElementRemote` interface have two more parameters compared with their counterparts in the `Element` interface. One parameter is an integer value that identifies the referred element object. The other parameter is an `Identity` object, which is used to identify the source of the request.
- Several methods defined in the `Element` interface are not included in the `ElementRemote` interface. The reason is that these methods can directly be processed locally on the core server. For instance, the methods `getNumExternalNodes()`, `getNumDOF()`, and `getExternalNodes()` are not defined in the

ElementRemote interface because they do not need to be processed by a distributed element service.

- Although it is not shown in Figure 4.6 for the purpose of clarity, exception handling is included in the implementation for all the methods. Java RMI requires all the remote methods to handle RemoteException. Some exceptions related to I/O need to be taken care of as well.

For a typical distributed element service, there is a pair of classes that implement the ElementRemote interface, namely the ElementServer and the ElementClient. Every distributed element service implements an ElementServer, which serves as a wrapper for the actual code of the element service. The core of the collaborative framework has a corresponding ElementClient class to communicate with the ElementServer class. In the Java RMI infrastructure, the ElementClient object plays the role of a *stub* that forwards the core server's requests to the element service. The ElementServer object is a *skeleton* that defines the entry point of this element service.

Once the ElementServer and the ElementClient classes are implemented and installed, the interaction between the distributed element service and the OpenSees or other core server can be established by conforming to the defined protocol. When the core of the collaborative framework wants to access a distributed element service, it calls on the methods defined in the ElementClient. It is up to the ElementClient to access the ElementServer and to obtain the requested data. Figure 4.7 shows the interaction diagram of a typical linear distributed element service. For the OpenSees core, a StubElement is provided because C++ application cannot directly access Java methods – the StubElement is needed to forward the requests to the ElementClient. The StubElement is implemented in C++, which makes it possible to be directly invoked by the OpenSees core. For the remote element service, an ElementImpl is implemented to serve as a wrapper for the methods of the element service. The actual element service itself may be a legacy application, which can be written in C++, C, and/or Fortran. Once

wrapped and conformed to the protocol, the legacy application can be integrated into the distributed service architecture.

Figure 4.7 illustrates the invocation of two remote methods. The `formElement()` is called when the OpenSees core is building the finite element model. The element input data is forward to the element service during this phase. After the element service receives all the necessary input data, it starts generating output data (stiffness, mass, damping, etc.). The `getStiff()` method is invoked to request the stiffness matrix of an element during the analysis phase of the OpenSees core. Other type of output data of each element can also be obtained by calling the corresponding remote methods.

```
public class ElementRemote extends Remote {
    // This is the service name for publishing.
    public static final String SERVICE = "ElementService";
    // This is the port number, could be changed as needed.
    public static final int PORT = 5432;

    // This function is used to send the element data to server.
    public int formElement(int tag, Identity src, char[] input);
    // This function is used to perform house cleaning.
    public int clearElements(Identity src);

    public int commitState(int tag, Identity src);
    public int revertToLastCommit(int tag, Identity src);
    public int revertToStart(int tag, Identity src);
    public int update(int tag, Identity src);

    // Form element stiffness, damping and mass matrix.
    public MyMatrix getTangentStiff(int tag, Identity src);
    public MyMatrix getSecantStiff(int tag, Identity src);
    public MyMatrix getDamp(int tag, Identity src);
    public MyMatrix getMass(int tag, Identity src);

    public void zeroLoad(int tag, Identity src);
    public MyVector getResistingForce(int tag, Identity src);
    public MyVector getTestingForceIncInertia(int tag, Identity src);
}
```

Figure 4.6: Interface for the ElementRemote Class

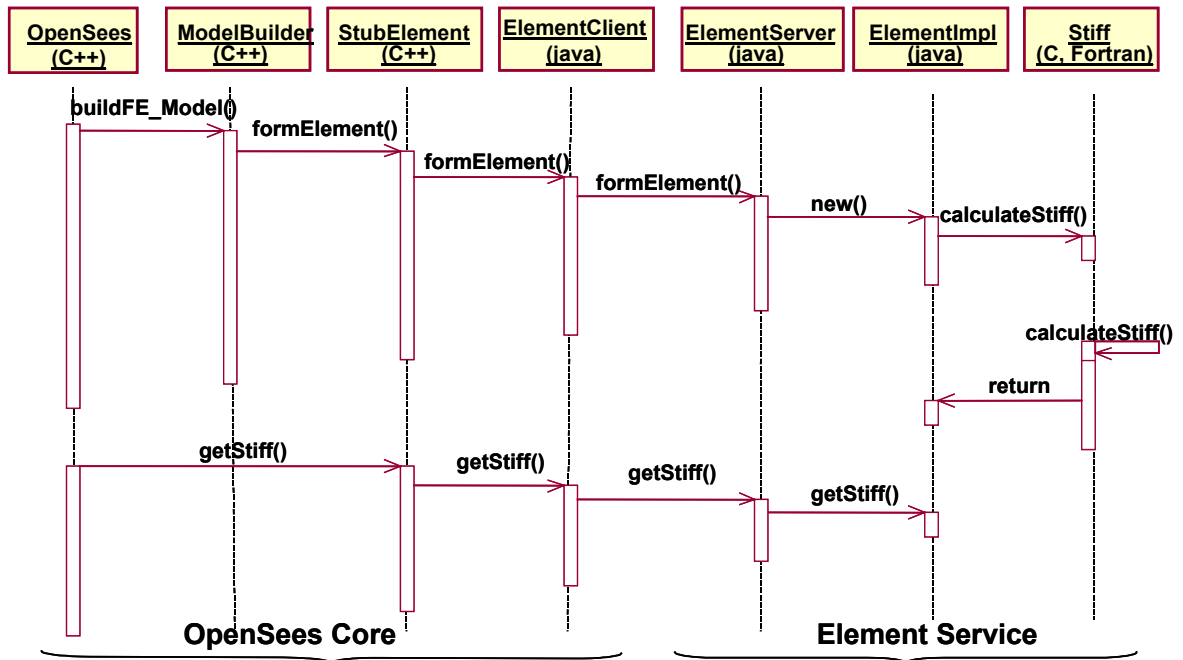

Figure 4.7: Interaction Diagram of Distributed Element Service

4.2.3 Implementation

As we discussed earlier, the remote communication of a distributed element service is implemented using Java RMI. Figure 4.8 shows partial sample code of an `ElementClient` class and an `ElementServer` class. The `ElementClient` class resides on the OpenSees core server's site, while the `ElementServer` class locates on the service provider's site. The `ElementClient` and the `ElementServer` together provide a communication channel and make the network traffic transparent to both the analysis server core and the element service. When the analysis core needs to access the distributed element, it instantiates and makes method calls to the remote element service in the same way as it treats a local element object.

```
public class ElementClient {

    // based on the server name and port number, creates stub object.
    public ElementClient(String serverName)
    {
        Identity server = theRANS.query(serverName);
        System.setSecurityManager(new RMISecurityManager());
        String name = "//" + server.IP + ":" + server.PORT +
            "/" + server.SERVICE;
        theStub = (ElementRemote)Naming.lookup(name);
    }

    // the stub is a proxy to the real server object.
    public void formElement(int tag, Identity src, char[] input)
    {
        theStub.formElement(tag, src, input);
    }

    public MyMatrix getTangentStiff(int tag, Identity src)
    {
        MyMatrix result = new MyMatrix(4, 4);
        result = theStub.getTangentStiff(tag, src);
        return result;
    }
}

public class ElementServer extends UnicastRemoteObject
    implements ElementRemote {

    // the ElePool provides functions similar to that of a hash table
    private ElePool allElements = new ElePool();

    public void formElement(int tag, Identity src, char[] input)
    {
        ElementImpl newElement = new ElementImpl(tag, input);
        allElements.put(tag, src, newElement);
    }

    public MyMatrix getTangentStiff(String tag, Identity src)
    {
        ElementImpl oneElement=(ElementImpl)allElements.get(tag, src);
        result = oneElement.getTangentStiff();
        return result;
    }
}
```

Figure 4.8: Sample ElementClient and Sample ElementServer

In order to use a distributed element service, the core server first needs to locate the corresponding `ElementServer` object. This process is implemented in the constructor of the `ElementClient` class. As shown in Figure 4.8, the location of an `ElementServer` object can be found through the RANS server and Java RMI naming service. The Java naming service is supported by the **Naming** class, which is a Java API class that provides methods for storing and obtaining references to remote objects in the remote object registry. Since a distributed service is identified by its name, the name can be used as an input to query the RANS sever to find the related information about the service. After we obtain the service information (server IP, port number, and service type), the method `lookup()` on the Java **Naming** class is called to find a local reference to the `ElementServer`, which implements the `ElementRemote` interface.

Once the analysis core establishes a reference to the `ElementServer` object, it may invoke remote methods on the object. Figure 4.8 shows some sample code for the usage of two remote methods: `formElement()` and `getTangentStiff()`. One parameter of the `formElement()` method is a character array, which is used to represent the element input data. The representation of the element data is achieved by a technique called *object serialization*. Upon receiving a `formElement()` request from the `ElementClient`, the `ElementServer` instantiates a new `Element` object and start a new thread to compute the element data (stiffness matrix, mass matrix, etc.). After the computation is complete, the element can be saved in an **ElePool** object, which is implemented using a hash table for temporarily holding element data. The key to this hash table is the `Identity src` and the integer `tag`. The reason that the `ElementServer` needs the `Identity` object from the `ElementClient` object is that the `ElementServer` may serve multiple clients, and thus a mechanism is needed to identify the source of the remote requests. During a structural analysis, when the OpenSees core needs the stiffness matrix, it issues a call `getTangentStiff()` to the `ElementServer` object for the stiffness matrix. At this stage, the **ElePool** object is searched for the requested `Element` object and the stiffness matrix can be sent back to the `ElementClient` as the return value of the remote method.

After the communication is established, the core analysis program can treat the distributed element in the same way as a local element. Again, the searching and the binding of an online remote element service are automated – the user of the collaborative framework is not aware of the difference between a local element and an online element.

4.3 Dynamic Shared Library Element Services

The distributed element service model described in the previous section is flexible and convenient. However, the approach does carry some overhead on remote method invocation, which is generally more expensive than local method call. The system performance is reduced because a remote method has to be invoked for accessing every distributed element. A dynamic shared library (or simply a shared library) element service is designed to alleviate the performance bottleneck and to improve the system performance without losing the flexibility and other benefits of the distributed services. Instead of being compiled to a static library and merged to the core server, an element service is built as a dynamic shared library and located on the element service provider's site. During the system runtime, the installed shared library can be automatically downloaded to the core server and linked with the OpenSees core. The shared library element service allows the replacement of an element service without reinitiating the core server, as well as provides a transparent service to the users.

4.3.1 Static Library vs. Shared Library

Most modern operating systems allow us to create and use two kinds of libraries – static libraries and shared libraries. A dynamic shared library differs in many ways from a static library. Static libraries are just collections of object files that are linked into the program during the linking phase of compilation, and are not relevant during runtime. Only those object files from the library that are needed by the application are linked into

the executable program. Shared libraries, on the other hand, are linked into the program in two stages. First, during compilation time, the linker verifies that all the symbols (functions, variables and the like) required by the program are either linked into the program or existed in one of its shared libraries. The object files from the shared libraries are not inserted into the executable file, but rather the linker notes in the executable code that the program depends on shared libraries. Secondly, during runtime, a program in the system (called a dynamic loader) checks out which shared libraries are needed for the program, loads them into memory, and attaches them to the copy of the program in memory. A detailed comparison between static library and shared library is presented in Table 4.2.

Table 4.2: The Comparison Between Static and Shared Libraries

	Static Library	Shared Library
Access time	During compilation time.	During program runtime.
Code sharing	The static library cannot be shared or replaced at runtime.	Significant portions of code can be shared among programs at runtime, reducing the amount of memory use.
Program size	A copy of the library is linked to each program that uses the library.	The size of the executable is smaller compared with static library.
Runtime replacement	Linking happens at compilation time, thus does not allow runtime replacement.	The shared library can be replaced at runtime without relinking with the application.
Performance	The performance overhead happens at compilation time.	Runtime linking has an execution-time cost.
Environment change	Static library is not sensitive to the system environment change.	Moving a shared library to a different location may prevent the system from finding the library and executing the program.

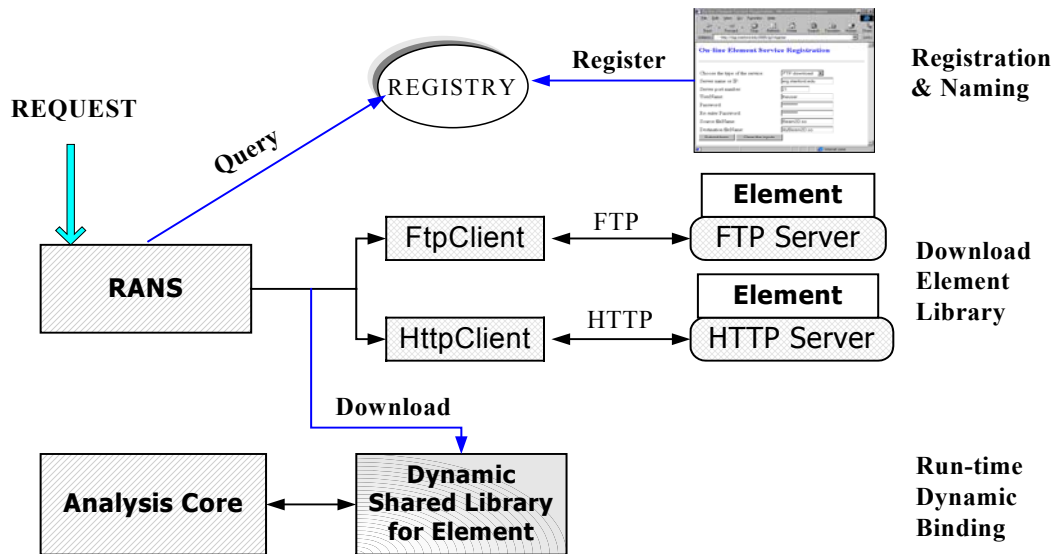

Figure 4.9: The Mechanics of Dynamic Shared Library Element Service

4.3.2 Mechanics

The mechanics of the dynamic shared library element service is depicted in Figure 4.9. In this approach, the element code is built in the form of a dynamic shared library conforming to a standard interface. The developed shared library can be placed on an FTP server or an HTTP server on the online element service provider's site; and the service needs to be registered to the analysis core's RANS server. During a structural analysis, if the core needs the element, the RANS server will be queried to find the pertinent information about this element service. After the location of the element service is found, the shared library is downloaded from the service provider's site and is placed on a predetermined location on the core's computer. The downloaded shared library can then be dynamically accessed at runtime by the analysis core whenever the element is needed. Since the RANS server keeps track of the modifications and versioning of the shared library element services, the replacement of an element service can be easily achieved by downloading the updated copy of the shared library.

There are many advantages for the shared library element services. One advantage of linking dynamically with shared libraries over linking statically with static libraries is that the shared library can be loaded at runtime, so that different services can be replaced at runtime without re-compilation and re-linking with the application. Another benefit of using dynamic shared library is that the shared library is in binary format. The binary format guarantees that the source code of the element will not be exposed to the core server, making the building of proprietary software components easier. This also implies that the element developer controls the maintenance, quality, and upgrade of the source code, facilitating bug-fixing and version control of the element service. However, the dynamic shared library element service also bears some disadvantages. The most prominent one is platform dependency. In order to support dynamic loading and binding, in most cases the shared library must be built on the same platform as the core server. Other disadvantages include potential security problem and minor performance overhead due to network downloading and dynamic binding.

4.3.3 Implementation

There are three issues associated with the implementation of the dynamic shared library element service. The first is about how to build a shared library; the second is related to the downloading of shared library services; and the third is regarding the dynamic binding of a shared element library.

We first address the issue of how to build a dynamic shared library. As we mentioned earlier, the building of dynamic shared library is platform dependent. The dynamic shared libraries are supported and implemented on various operating systems:

- **Windows:** In Windows platform, shared libraries are called dynamic link libraries (DLLs) [80] and a DLL file is often given `.dll` file name suffix. DLLs are primarily controlled by three functions: `LoadLibrary()`, `GetProcAddress()`, and `FreeLibrary()`. The Win32 API function `LoadLibrary()` is used to load

a DLL into the caller's address space. `GetProcAddress()` is used to retrieve pointers to the DLL's exported functions so that the client can call those functions in the DLL. When a client has finished using the library, the DLL is freed by calling `FreeLibrary()`. The Microsoft Visual C++ compiler can be used to compile DLLs and programs that load them.

- **Linux:** For the Linux platform, the `dlopen` family of routines is used to control the shared libraries [83]. The library should be named with a `.so` file name suffix. In order to find the location of a library, Linux searches along the `LD_LIBRARY_PATH` environment variable, which is a colon-separated list of directories. The directories listed in `/etc/ld.so.cache` file and the directories `/usr/lib` and `/lib` will also be searched. The GNU C compiler (`gcc` and `g++`) can be used to compile shared libraries or programs that load them.
- **SunOS:** The shared libraries under SunOS are very similar to that under Linux environment. A shared library is loaded using the method `dlopen()`, the functions of a shared library is called using `dlsym()`, and the shared library is unloaded using `dlclose()`. The Sun Workshop [114] compiler (`CC` and `cc`) can be used to compile shared libraries and programs that load them.

In the prototype implementation of the collaborative framework, Sun workstations are used as the development platform. For illustration purpose, we will focus on building dynamic shared libraries in the SunOS environment. The shared library element services on other platforms can be constructed similarly. In the SunOS environment, the creation of a shared library is quite similar to the creation of a static library – compile a list of object files and then insert them into a library file. However, there are two major differences:

1. Compile for Position Independent Code (PIC). When the object files are generated, the positions that these files will be inserted in a program are unknown. Thus, all the subroutine calls in the shared library need to use relative addresses, instead of absolute addresses. We can use the compilation flag `-fPIC` to generate this type of code.
2. Library File Creation. Unlike a static library, a shared library is not an archive file. We need to tell the compiler to create a shared library instead of a final program executable file. This can be achieved by using the `-shared` flag with the Sun compiler.

Thus, the set of commands we may use to create a shared library would be as follows:

```
cc -fPIC -c util_file.c
cc -fPIC -c element1.c
cc -shared libele1.so util_file.o element1.o
```

The first two commands compile the source files with the `-fPIC` option, so that they will be suitable for use in a shared library. The last command asks the compiler to generate a shared library named `libele1.so`.

After a shared library element service is implemented and tested on the service developer's site, the next problem we need to deal with is how to automatically download the library to the analysis core server. This task can be achieved by utilizing one of the two popular Internet protocols (FTP and HTTP) to transfer the library files. On the element service developer's site, the developed shared element libraries are placed on either a FTP server or a web server. The location of the shared library and other pertinent information can be submitted to the core server via the RANS interface. On the analysis core server's site, two new classes, namely `FtpClient` and `HttpClient`, are implemented. These two classes can query the RANS server for the related information of a particular element service, and then use queried result to find the element libraries and to download the library files from the element developer's site. The downloaded libraries are saved on

the core server by placing the library files into a pre-determined directory. The directory is defined in the `LD_LIBRARY_PATH` environment variable, which by default is used by a program to determine where to find dynamic shared libraries.

```
#include <dlfcn.h> /* defines dlopen(),dlsym(), etc. */
...
void *lib_handle; /* handle of the shared library */
char lib_name[100]; /* contains the name of the library file */

Matrix (*getTangentStiff)(int tag);

/* load the desired shared library */
lib_handle = dlopen(lib_name, RTLD_LAZY);

/* load the function in the library */
getTangentStiff = dlsym(lib_handle, "getTangentStiff");
error = dlerror();

/* call the library function */
kMatrix = (*getTangentStiff)(tag);

/* finally, close the library */
dlclose(lib_handle);
```

Figure 4.10: The Binding of a Dynamic Shared Library

Once the shared element library is downloaded and placed in the pre-assigned directory, the analysis core server can start using the library. Figure 4.10 shows some sample code for the binding of a dynamic shared library. In order to use a dynamic shared library, the first step is to open and load the library by using `dlopen()` function. The `dlopen()` function takes two parameters: one is the full path to the shared library and the other is a flag defining whether all symbols referred to by the library need to be checked immediately or only when the symbols are used. In our case, we may use the “lazy” approach (`RTLD_LAZY`) of checking only when used. After we obtain a handle to the loaded shared library, we can search symbols (both functions and variables) in it. Figure

4.10 shows the process of using `dlsym()` to find a reference to the library function named `getTangentStiff()`. Since errors might occur anywhere along the code, `dLError()` is invoked to perform error checking. For a function defined in a shared library, we can invoke and access the function in the similar way as we access a function in a static library. The invocation of a shared library function `getTangentStiff()` is presented in Figure 4.10. The final step of using a dynamic shared library is to invoke `dlclose()` to close down the library. This should only be done if we are not intending to use the library soon. If we do, it is better to leave it open, since library loading takes time.

4.4 Application

A prototype of the Internet-enabled collaborative framework is implemented by using Sun workstations as the hardware platform. These workstations are connected in a Local Area Network (LAN) environment with a bandwidth of 10Mbps. The analysis core is based on OpenSees. Apache HTTP server is used as the web server, and Apache Tomcat 4.0 is utilized as the Java Servlet server. MATLAB 6.1 is used as the engine to build a simple post-processing service, which takes a data file as input and then generates a graphical representation.

4.4.1 Example Test Case

The prototype system is employed to conduct an online nonlinear dynamic analysis on the model shown in Figure 3.8. As an example, the ElasticBeamColumn element in the example model can be built as an online element service, which resides on a separate computer other than the core server. Both distributed element service and shared library element service are implemented. In order for these element services to be used by the analysis core, they have to be registered to the central server by saving the information on

the RANS server. Figure 4.11 shows the web-based interface of the RANS server for the registration of the distributed *ElasticBeamColumn* element service. The information required for the registration service includes the type of the service, the name of the service, the IP and port number of the service provider's site, developer's identity and password, and an optional description of the service. If the input name is already existed in the service list, the RANS server will inform the developer to choose a different name. Based on the input data, the RANS generates a unique **Identity** object for the service. This **Identity** can be queried and used later to find the service and to handle the binding of the online element service with the core server.

Figure 4.12 illustrates the interaction among the distributed services during a simulation of the model. The analysis core is running on a central server computer called *opensees.stanford.edu*. The web server and Java Servlet server are also running on this computer. The developed online *ElasticBeamColumn* element services are running on a computer named *galerkin.stanford.edu*. As we indicated before, users only need to know the location of the central server (*opensees.Stanford.edu*) without the awareness of the underlying distributed framework. Although in the figure we only illustrate the usage of the web-based interface, the users can also communicate with the server via a MATLAB-based interface, or other types of user interfaces. The input Tcl file can be submitted to the server using a web-based interface (as shown earlier in Fig. 5(a)). Upon receiving the request, the central server starts a new process to perform the nonlinear dynamic analysis of the model. When the analysis is in need of certain type of element (in this case, *ElasticBeamColumn* element), the RANS server will be consulted to find the online element service. Once the communication between the element service and the central server is established, the analysis can continue as if the element resides on the central server.

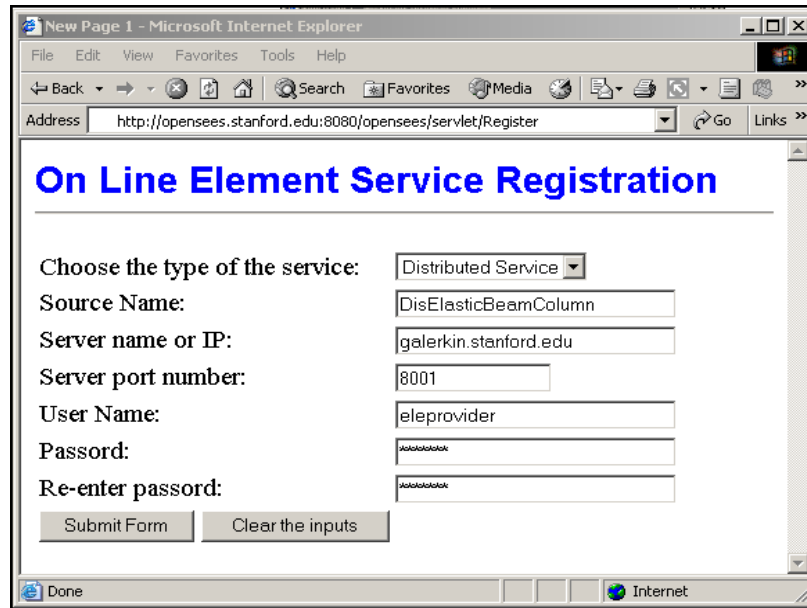

The image shows a screenshot of a Microsoft Internet Explorer browser window. The title bar reads "New Page 1 - Microsoft Internet Explorer". The address bar contains the URL "http://opensees.stanford.edu:8080/opensees/servlet/Register". The main content area displays a registration form titled "On Line Element Service Registration" in blue text. The form includes the following fields and controls:

- "Choose the type of the service:" with a dropdown menu set to "Distributed Service".
- "Source Name:" with a text input field containing "DisElasticBeamColumn".
- "Server name or IP:" with a text input field containing "galerkin.stanford.edu".
- "Server port number:" with a text input field containing "8001".
- "User Name:" with a text input field containing "eleprovider".
- "Password:" with a masked text input field (asterisks).
- "Re-enter password:" with a masked text input field (asterisks).
- Two buttons at the bottom: "Submit Form" and "Clear the inputs".

The browser's status bar at the bottom shows "Done" and "Internet".

Figure 4.11: Web Interface for Registration and Naming Service

During the simulation, some selected analysis results are saved in the database, and certain information will be returned to the user's browser to inform the progress of the simulation (similar to Figure 3.10(b)). After the analysis is finished, typical analysis results can be queried, or the results can be downloaded from the server and saved as a data file. To facilitate the plotting of analysis results in a user's web browser, the MATLAB-based distributed post-processing service is employed in this example. For example, if the user wants to plot response time history of node 1 (which is the left node on the 18th floor of the structural model), the central server (*opensees.Stanford.edu*) will forward the time history response data to the MATLAB-based service running on a separate computer (in this case, *epic21.stanford.edu*). Once the post-processing service receives the request, it automatically starts a MATLAB process to plot the time history response and then save it in a file of PNG (Portable Network Graphics) format. In responding to the user's request, this file can later be sent to the client and be plotted on the user's browser, as shown in Figure 4.13.

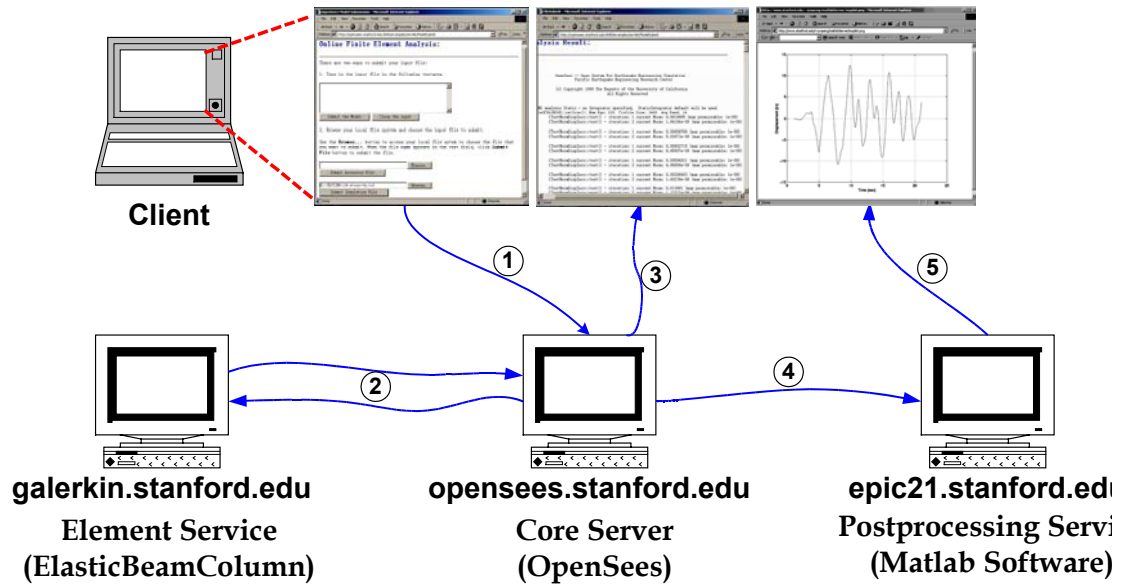

Figure 4.12: Interaction of Distributed Services

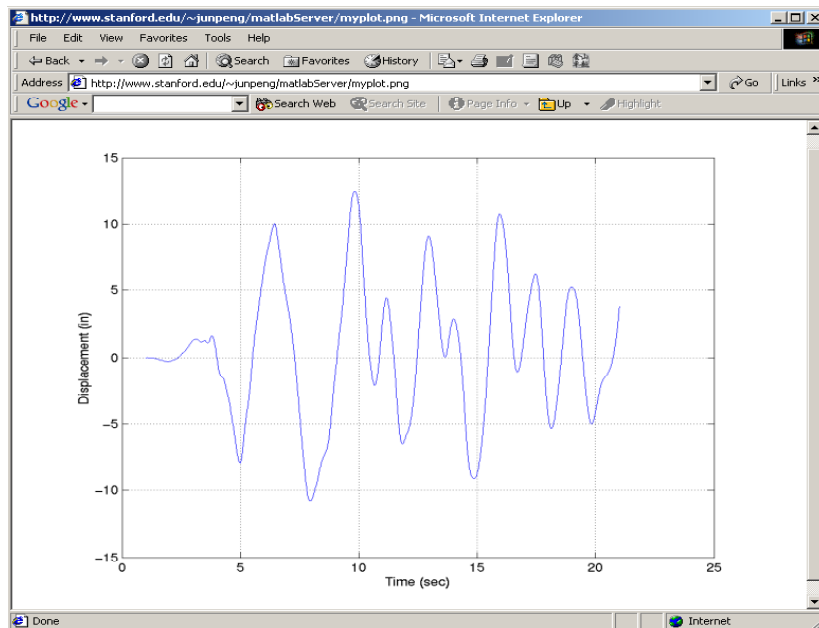

Figure 4.13: Graphical Response Time History of Node 1

In this example, the simulation was the result of the collaboration among four computers and several services running on these computers. The services may be distributed on different computers on the Internet, residing within their own address space outside of the central server, and yet they appear as though they were local to the client.

4.4.2 Performance of Online Element Services

To assess the relative performance, we compare three types of ElasticBeamColumn element service developed for the analysis model: static element library, distributed element service, and dynamic shared library element service. The static element library is the traditional way of incorporating new elements, and the static ElasticBeamColumn element runs on the same computer (*opensees.Stanford.edu*) as the core server. On the other hand, the distributed element service and shared library element service are located on a separate computer named *galerkin.Stanford.edu*. To assess the performance of each type of element service, structural simulations are performed on the 18-story one bay model. Table 4.3 lists the total analysis time for the simulations with different types of element services. The number of time steps shown on the table indicates the number of data points used in the input earthquake record.

Table 4.3: The Performance of Using Different Element Services

Number of time steps	Static library Element Service	Distributed Element Service	Shared library Element Service
50	4.25 s	108.06 s	8.91 s
300	38.24 s	856.95 s	51.53 s
1500	204.47 s	6245.6 s	284.82 s

From Table 4.3, we can see that the distributed element service imposes severe performance penalty to the system. This is mainly because the network communication is handled at the element level. For every action on every element (sending input data, obtaining stiffness, etc.), a remote method is invoked. Compared with a local method call, a remote method invocation has higher cost, which involves the time for parameter marshalling and unmarshalling, the initialization cost, the network latency, the communication cost, and other types of associated performance penalties. One avenue to improve the performance is to bundle the network communication. Instead of using the fine-grain element level communication, both sides of the element service can set up a buffer for temporarily storing element data. The element data will then be sent out when there is enough number (say, 20) of elements saved in the buffer. This method would be able to reduce the cost associated with remote method initialization and network latency.

The shared library element service has better system performance than the distributed element service and yet not losing the flexibility and other benefits of distributed services. However, the shared library element service does incur performance overhead compared with the static element service. The performance overhead is primarily associated with the downloading of library files and the runtime dynamic binding of libraries. To reduce these costs, two types of local caching techniques could be utilized: one is related to static file caching, the other is runtime shared library caching. As we discussed earlier, the RANS sever has a simple versioning mechanism to keep track of the modifications to element services. If there are no major changes to a shared library service, the downloaded copy of the shared library could be reused, eliminating the need for downloading library files. During the analysis core server's initialization phase, the registered shared libraries are loaded and bound with the analysis core. If there are no newer versions of the libraries, these shared libraries will stay loaded on the server. When the shared library element service is accessed, the library loading process then is not needed. By adopting these caching techniques, the performance gap between using shared library element service and using static element service can be reduced.

4.5 Summary and Discussion

The collaborative framework as discussed in the previous chapter consists of six distinct modules, and this chapter describes three of them, namely the registration and naming service, the distributed element service, and the dynamic shared library element service. The RANS sever allows the analysis core to find the registered services and to monitor the modifications to these services. Since RANS guarantees that a unique name is associated with each service, the name can be used to query and identify a service. The distributed element service and dynamic shared library element service are two forms of online element services, which are introduced to the core framework to facilitate the distributed usage and the collaborative development of an finite element structural analysis program. An element service may be developed as a component that can be easily integrated with the core server through a *plug-and-play* environment.

The collaborative framework has multiple benefits, within which two prominent ones are standardized interface and network transparency. An online service is best defined in terms of the protocol it uses, rather than particular software participated in the system. Any implementation of these protocols is able to participate in the system, interoperating with completely independent implementations, but using the same protocols. The standard communication protocols allow a service to be replaced easily and facilitate the concurrent development of standardized components. The collaborative framework system provides an execution environment that is network transparent. Being network transparent means the execution environment provides an abstraction that is the *same* whether executing locally, remotely or distributively – the network is not visible. End users of the collaborative framework do not need to be aware of the complexity of the core server (in terms of both hardware and software infrastructure), hence they do not have the associated development and maintenance challenges.

The collaborative framework with online services described in this chapter does not address issues of authentication and security. The security issues could be addressed in

the network level, especially by utilizing the Public Key Infrastructure (PKI) that supports digital signatures and other public key-enabled security services [111]. One example of managing security for high-performance distributed computing is the security architecture [37] used for Computational Grid [38], where the integrity and confidentiality of communications are ensured. Another issue of the collaborative framework is scalability. The current implementation relies on Java's multithreading feature to handle simultaneous requests. Our test result shows that the performance will be substantially degraded when more than a dozen clients access the server simultaneously. This scalability problem could be tackled by providing multiple core servers, utilizing more powerful computers, and deploying parallel and distributed computing environment [24, 71].

Chapter 5

Data Access and Project Management

The importance of engineering data management is increasingly emphasized in both industrial and academic communities. The objective of using an engineering database is to provide the users the needed engineering information from readily accessible sources in a ready-to-use format for further manipulation. Such trend can also be observed in the field of finite element analysis. Modern finite element programs are increasingly required to be linked to other software such as CAD, graphical processing software, or databases [74]. Data integration problems are mounting as engineers confront the need to move information from one computer program to another in a reliable and organized manner. The handling of data shared between disparate systems requires the definition of persistent and standard representations of the data, and corresponding interfaces to query the data. Data must be represented in such a manner that they can facilitate interoperation with humans or mechanisms that use other persistent representations [117].

This chapter presents a prototype implementation of an online data access system for the open collaborative software framework [96]. In this work, a COTS database system is linked with the central server to provide the persistent storage of selected analysis results. By adopting a COTS database system, we can address many of the problems encountered by the prevailing file system-based data management. Current trend sees that the

commercial database industry is shifting to use the Internet as the preferred data delivery vehicle. Various Internet computing is supported by backend databases. Finite element computing is no exception. The online data access system would allow the users to query the core server for useful analysis results, and the information retrieved from the database through the core server is returned to the users in a standard format. Since the system is using a centralized server model, the data management system can also support project management and version control of the projects.

This chapter is organized as follows:

- Section 5.1 presents the multi-tiered architecture of the online data access system. The communications between different tiers are discussed.
- The data storage scheme is presented in Section 5.2. A selective data storage scheme is introduced to provide flexible support for the tradeoff between the time used for reconstructing analysis domain and the space used for storing the analysis results.
- Section 5.3 describes the data representations of the online data access system. Both internal and external data representations are described.
- Section 5.4 discusses several issues regarding data query and retrieval. A data query language is introduced in this section, and the data query interfaces are presented.
- Section 5.5 presents two test case examples for the usage of the data access and project management system. The benefits of using the proposed data access system are discussed in this section.

5.1 Multi-Tiered Architecture

As shown in Figure 3.3, the online data access system is designed as one module of the Internet-enabled collaborative framework to provide researchers and engineers with easy and efficient access to the structural analysis results. During an analysis, certain selected results and pertinent data are saved, and a data storage and access system is employed to manage these data.

To design a data management system, we first need to decide what kind of media should be used to store the data. Presently, the data storage for finite element analysis programs primarily relies on file systems. Since most modern operating systems have built-in support for file usage, directly using file systems to store data is a straightforward process. However, there are many intrinsic drawbacks associated with the direct usage of file system for storing large volume of data. File systems generally do not guarantee that data cannot be lost if it is not backed up, and they do not support efficient random access in which case the locations of data items in a particular file are unknown. Furthermore, file systems do not provide direct support for a query language to access the data in files, and their support for a *schema* of the data is limited to the creation of file directory structures. Finally, file systems cannot guarantee data integrity in the case of concurrent access. Instead of directly using the file systems to store the analysis results of a finite element analysis, these results can also be saved in database systems. Most database management systems (DBMS) allow certain structures for the saved data, allow the users to query and modify the data, and help manage very large amounts of data and many concurrent operations on the data. In the prototype implementation of the online data access and management system, both file system and database systems can be employed for data storage. Because of the benefits of database systems over file systems, we focus our efforts on using database systems to store the selected analysis results. Similar techniques used with database systems can be directly applied to data management systems based on file systems.

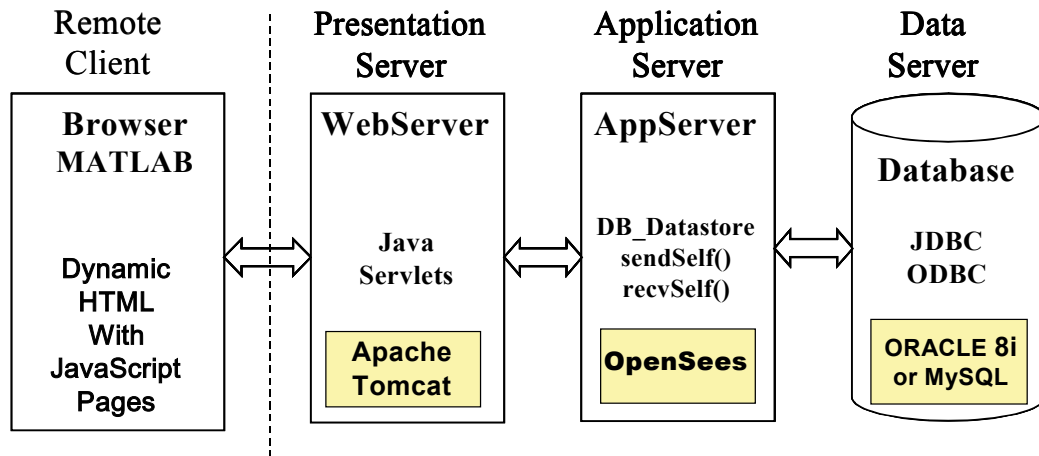

Figure 5.1: Online Data Access System Architecture

As depicted in Figure 3.1, a COTS database system is linked with the central server to provide persistent storage of selected analysis results for the open collaborative software framework. Since the analysis core of the open collaborative framework resides on a central server as a compute engine, the online data access system needs to be designed accordingly. Figure 5.1 depicts the architecture of the online data access system. A multi-tiered architecture is employed as opposed to the traditional two-tier client-server architecture. The multi-tiered architecture provides a flexible mechanism to organize distributed client-server systems. Since components in the system are modular and self-contained, they could be designed and developed separately. The multi-tiered online data access system has the following components:

- A standard interface is provided for the **Remote Client** programs to access the server system. Application programs, such as web browsers or MATLAB, can access the server core and the analysis results from the client site via the pre-defined communication protocols. Using dynamic HTML pages and JavaScript code, together with the mathematical manipulation and graphic display capability of MATLAB, the client has the ability to specify the format and views of analysis results.

- Java Servlet enabled **Web Server** is employed to receive the requests from the clients and forward them to the *Application Server*. The *Web Server* also plays the role of re-formatting the analysis results in certain HTML format for the web-based clients. In the prototype system, Apache HTTP web server is employed to handle the requests from the users, and Apache Tomcat is employed as the Java Servlet server. Details about the *Web Server* have been discussed earlier in Chapter 3.
- The **Application Server** is the middle layer for handling communication between the *Web Server* and the *Data Server*. The *Application Server* also provides the core functionalities for performing analyses and generating analysis results. In the prototype system, the finite element analysis core is situated in the *Application Server*. Since the analysis core is a C++ application, the integration of the analysis core with Java Servlet server needs to be handled with special care. In order to keep the design modular, the communication between Java applications (Servlet server) and C++ program (the analysis core) is handled in the data access system via a socket connection, instead of directly using JNI. Specific socket classes written in both Java and C++ are implemented to provide communication channels between Java Servlets and the analysis core application.
- A COTS database system is utilized as the **Data Server** for the storage and retrieval of selected analysis results. Examples of COTS database systems include: Oracle [57] and MySQL [26]. The communication between the *Application Server* and the *Database* is handled via the standard data access interfaces based on Open Database Connectivity (ODBC) that most COTS database systems provide. ODBC makes it possible to access different database systems with a common language.

In this research, OpenSees [76] is employed as the finite element analysis platform for the analysis core in the Internet-enabled collaborative software framework. To facilitate the data storage and access, a new class, FE_Datastore, is introduced to the object-oriented FEA core program OpenSees, as shown in Figure 5.2. The FE_Datastore is a subclass of the Channel class, which is implemented in OpenSees to facilitate data

communication between two processes. A `FE_Datastore` object is associated with a `Domain` object to store and retrieve the state of this `Domain` object. The `FE_Datastore` class has many subclasses, including `File_Datastore` and `DB_Datastore`. The `File_Datastore` class is introduced to facilitate the storage of analysis results in a file system. The `DB_Datastore` is the subclass that defines the interface between OpenSees and a database system. The `DB_Datastore` class uses Open Database Connectivity (ODBC) to send and retrieve data between the OpenSees core objects and a COTS database. Since the state of domain objects (Node, Element, Constraint, and Load, etc.) can be represented as either a byte stream or a sequence of ID, Vector, and Matrix objects, the `DB_Datastore` class provides methods to send and receive byte streams, ID, Vector and Matrix objects. The interface for the `DB_Datastore` class is shown in Figure 5.3. Subclasses of the `DB_Datastore` class are implemented for different database systems, for example, `OracleDatastore` class is implemented for Oracle database system and `MysqlDatastore` class is implemented for MySQL database system. Other database systems can be included by defining new subclasses of `DB_Datastore` class.

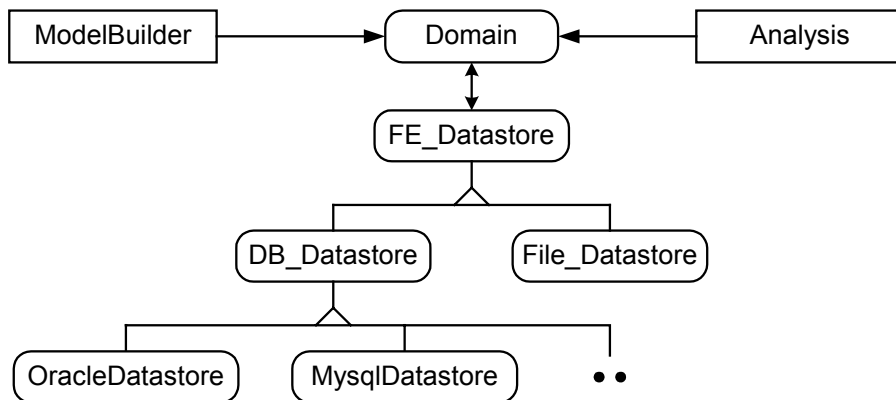

Figure 5.2: Class Diagram for `FE_Datastore`

```
class DB_Datastore {
    DB_Datastore(char* dbName, Domain &theDomain,
                 FEM_ObjectBroker &broker);
    ~DB_Datastore();

    // method to get a database tag.
    int getDbTag(void);
    // methods to set and get a project tag.
    int getProjTag();
    void setProjTag(int projectTag);

    virtual int sendObj(int commitTag, MovableObject &theObject,
                       ChannelAddress *theAddress);
    virtual int recvObj(int commitTag, MovableObject &theObject,
                       FEM_ObjectBroker &theBroker, ChannelAddress *theAddress);

    virtual int sendMatrix(int dbTag, int commitTag,
                           const Matrix &theMatrix, ChannelAddress *theAddress);
    virtual int recvMatrix(int dbTag, int commitTag,
                           Matrix &theMatrix, ChannelAddress *theAddress);

    virtual int sendVector(int dbTag, int commitTag,
                           const Vector &theVector, ChannelAddress *theAddress);
    virtual int recvVector(int dbTag, int commitTag,
                           Vector &theVector, ChannelAddress *theAddress);

    virtual int sendID(int dbTag, int commitTag,
                       const ID &theID, ChannelAddress *theAddress);
    virtual int recvID(int dbTag, int commitTag,
                       ID &theID, ChannelAddress *theAddress);
}
```

Figure 5.3: Interface for the DB_Datastore Class

5.2 Data Storage Scheme

The usage of a database system in the online data access system has two distinct phases. The first phase is during the finite element analysis of a model, in which certain selected analysis results are stored in the database. The second phase occurs during the post-processing of a finite element analysis, where the analysis results are queried for the response of the analysis model. The goal of the data storage is to facilitate the data query and the design of a data storage scheme is to make the data query efficient and to

minimize storage space. Rather than storing all the interim and final analysis results, the online data management system allows saving only selected analysis data in the database. That is, the user has the flexibility to specify storing only certain selected data during a structural analysis. All the other analysis results can be accessed through the analysis core with certain re-computation. The selective storage scheme can substantially reduce the data storage space without severely sacrificing the performance of accessing the analysis results.

5.2.1 Selective Data Storage

A typical finite element analysis generates large volume of data. The analysis results can be saved and retrieved in two ways. One approach is to pre-define all the required data and save only those pre-defined data during the analysis. However, when analysis results other than the pre-defined ones are needed, a complete re-analysis is needed to generate those analysis results. For a nonlinear dynamic analysis of large structural models, the analysis needs to be restarted from scratch, which is an expensive process in terms of both processing time and storage requirement. The other approach is simply dumping all the interim and final analysis data into files, which are then utilized later to retrieve the required results as a postprocessing task. The drawbacks of this approach are the substantial amount of storage space and the potential poor performance due to the expensive search on the large data files.

There is an alternative to store only selected data, rather than storing all interim and final analysis results. Many approaches can be adopted for selecting the data to be stored during an analysis. The objective is to minimize the amount of storage space without severely sacrificing performance. For many commercial finite element analysis packages, such as ANSYS and ABAQUS, two types of output files can be created during an analysis. One type is a results file containing results for postprocessing. The results file is the primary medium for storing results in computer readable form. The results file can also be used as a convenient medium for importing analysis results into other

postprocessing programs. Users are able to specify in the analysis input the kind of data to be saved in the results file. The other type of output file is a restart file containing results for continuing an analysis or for postprocessing. The restart file essentially stores the state of an analysis domain so that it can be used for subsequent continuation of an analysis. Users are allowed to specify the frequency at which results will be written to the restart file.

In the engineering data access system, these two types of data storage (results and restart) are also supported. The data access system allows the collection of certain information to be saved as the analysis progresses, e.g. the maximum nodal displacement at a node or the time history response of a nodal displacement. A Recorder class is introduced in OpenSees to facilitate the selective data storage during an analysis. The Recorder class can keep track of the progress of an analysis and output the users' pre-specified results. Details about the usage of recorder command have been described elsewhere by McKenna [77]. Besides the recording functionalities, the data access system also has the restart capability. Certain selected data are stored during the analysis that allows the analysis domain to be restored to a particular state. The selected data need to be sufficient for the re-computation during postprocessing. In the data access system, we use object serialization [8] to facilitate the restart function. Object serialization captures the state of an object and writes the state information in a persistent representation, for example in the form of a byte stream. Consider a *Truss* element as an example, its nodes, dimension, number of DOFs, length, area, and material properties can be saved in a file or a database system during an analysis. Based on these stored data, a copy of the *Truss* object can be restored, and the stiffness matrix of the Truss element can then be re-generated. The object serialization technique can be associated with other storage management strategies to further reduce the amount of storage space. As an example, a data storage strategy named sampling at a specified interval (SASI) can be applied to nonlinear incremental analyses to dramatically reduce the storage requirement.

The restart function introduced in the engineering data access system is different, however, from those supported by current commercial finite element programs (e.g. ANSYS, ABAQUS, etc.). The restart function in the data access system relies on object serialization, which allows the developer of each class to decide what kind of information needs to be saved. As long as a replica of an object can be recreated with the saved data, the developer of the class can freely manipulate the saved data. This decentralized development control provides great flexibility and extendibility to the developers, especially in a distributed and collaborative development environment. For most commercial finite element programs, the data saved in the restart file must conform to certain data format. Furthermore, the restart file of most commercial finite element programs is organized as a sequential file, which may make the data retrieval efficient. On the other hand, the restart data saved in the data access system is retrieved randomly – the state of a particular object is accessed through a key value. Therefore, a particular object or a sub-domain of the finite element domain can be easily restored without retrieving unnecessary data. Because COTS database systems generally have indexing capability to support key-based searching, the required data retrieval mechanism of the data access system is one reason that makes COTS database systems preferable to file systems.

In the data access system, a COTS database system is associated with the finite element analysis core to provide data storage and query. For a typical structural analysis, the analysis core stores selected data into the database. During the post-processing phase, a request from a client for certain analysis result is submitted to the analysis core instead of directly querying the database. Upon receiving the request, the analysis core automatically queries the database for saved data to instantiate the required new objects. If necessary, these objects are initialized to restart the analysis to generate the requested results. Compared with re-performing the entire analysis to obtain the data that are not pre-defined, re-computation is more efficient since only a small portion of the program is executed with the goal of fulfilling the request. As opposed to storing all the data needed

to answer all queries, the selective storage strategy can significantly reduce the amount of data to be stored in the data management system.

5.2.2 Object Serialization

Ordinarily, an object lasts no longer than the program that creates it. In this context, persistence is the ability of an object to record its state so that the object can be reproduced in the future, even in another runtime environment. To provide persistence for objects, we can adopt a technique called object serialization, where the internal data structures of an object is mapped to a serialized representation that can be sent, stored, and retrieved by other applications. Through object serialization, the object can be shared outside the address space of an application by other application programs. A persistent object might store its state in a file or a database, which is then used to restore the object in a different runtime environment. The object serialization technique is one of the built-in features of Java and is used extensively in Java to support object storage and object transmission. There are currently three common forms of object serialization implementation in C++ [109]:

- **Java Model:** The Java serialization model stores all non-transient member data and functions for a serializable object by default. User can change the default behavior by overriding the object's `readObject()` and `writeObject()` methods, which specify the behaviors for serialization and deserialization of the object, respectively. This behavior can be emulated in C++ by ensuring that each serializable object implements two methods: one for serialization and another for deserialization.
- **HPC++ Model:** HPC++ [25] is a C++ library and a set of tools being developed by the *HPC++ Consortium* to support a standard model for portable parallel C++ programming. The serialization model was originally introduced in HPC++ to share objects in a network environment to facilitate parallel and distributed computing. Every serializable object declares a global function to be its *friend*. The runtime

environment then uses this global function to access an object's internal state to serialize or deserialize it. In C++, a class can declare an individual function as a *friend*, and this *friend* function has access to the class' private members without itself being a member of that class.

- **Template Factory Model:** The template factory based serialization model is used in Java Beans [67], and this model can be emulated in C++. A template is defined for each object type by a template factory. For serialization, the runtime environment can invoke the serialization method `setX()` of each object to write the state of the object to a stream. For deserialization, the type of an object needs to be obtained from its byte stream representation first. A template of the object then can be created by the template factory based on the object type. Subsequently, the internal states of the object needs to be accessed from the stream with `getX()` method. Since a template of the object can be created based on its type and the template usually already includes some member data and methods, the `setX()` method only need to write the member data that are not defined in the template. This is the major difference between the template factory model and the Java model, whose `writeObject()` method accesses all the member data and methods.

In the data access system, object serialization is supported via a technique that is similar to the Template Factory Model. In the implementation of the analysis core program OpenSees, all the *modeling* classes (Domain, Node, Element, Constraint, and Load, etc.), and *Numerical* classes (Matrix, Vector, ID, and Tensor, etc.) share a common *superclass* named MovableObject. The Interface for the MovableObject class is shown in Figure 5.4. The MovableObject class defines two important member methods: `sendSelf()` and `recvSelf()`. The `sendSelf()` method is responsible for writing the state of the object so that the corresponding `recvSelf()` method can restore it. The methods `sendSelf()` and `recvSelf()` rely on a particular type of Channel object to communicate with remote processes, which could be a remote application, a file system or a database system.

```
class MovableObject
{
public:
    MovableObject(int classTag, int dbTag);
    virtual ~MovableObject();

    int getClassTag(void) const;
    int getDbTag(void) const;
    void setDbTag(int dbTag);

    virtual int sendSelf(int commitTag, Channel &theChannel)=0;
    virtual int recvSelf(int commitTag, Channel &theChannel,
                        FEM_ObjectBroker &theBroker) =0;
}
```

Figure 5.4: Interface for MovableObject Class

In the data access system, the Domain state can be saved (serialization) in a database system during a structural analysis. The stored Domain state can then be restored (deserialization) during the post-processing of the structural analysis to facilitate data query processing. Since a Domain object is the container for all the modeling component objects such as Node, Element, Load, and Constraint, the Domain object can invoke the serialization behavior of its component object to serialize itself.

During Domain serialization, the Domain object accesses all its contained component objects and invokes the corresponding `sendSelf()` methods on the component objects to send out their state. The object state will then be piped to certain storage media (file system or database system) by a specified Channel object. For each component object, the first field that sends out is an integer *classTag*, which is a unique value used in OpenSees to identify the type of an object.

During Domain deserialization, the pre-stored data can be used to restore the Domain and its contained components. For each component, we first retrieve its *classTag* from the stored data. The retrieved *classTag* then can be passed to the template factory, which is a class named `FEM_ObjectBroker`. The main method defined in the `FEM_ObjectBroker` class is `MovableObject* getObjectPtr(int classTag);`

```

Domain::recvSelf(int savedStep, Channel &database,
                FEM_ObjectBroker &theBroker)
{
    // First we receive the data regarding the state of the Domain.
    ID domainData(this->DOMAIN_SIZE);
    database.recvID(this->INIT_DB_TAG, savedStep, domainData);

    // We can restore Nodes based on saved information.
    int numNodes = domainData(this->NODE_INDEX);
    int nodeDBTag = domainData(this->NODE_DB_TAG);

    // Receive the data regarding type and dbTag of the Nodes.
    ID nodesData(2*numNodes);
    database.recvID(nodeDBTag, savedStep, nodesData);

    for (i = 0; i < numNodes; i++) {
        int classTagNode = nodeData(2*i);
        int dbTagNode = nodeData(2*i+1);
        // Create a template of the Node based on its classTag.
        MovableObject *theNode = theBroker.getObjectPtr(classTagNode);
        // The Node itself tries to restore its state.
        theNode->recvSelf(savedStep, database, theBroker);
        // Add this Node to be a component of the Domain.
        this->addNode(theNode);
    }

    // Same as Nodes above, we rebuild Elements, Constraints, and Loads
    ...
}

```

Figure 5.5: Pseudo Code for recvSelf Method of the Domain Class

A template of the class corresponding to the *classTag* can be created by calling the constructor of the class that has no arguments. The returned value is a pointer to an object with the generic *MovableObject* type. Since each object knows its own type (a feature supported by the object-oriented *polymorphism*), the returned *MovableObject* can be further cast to create a specific template of the object. After a template for the object has been created, the remaining task of creating a replica of the object is to fill in the member fields. This can be achieved by calling the member method `recvSelf()` of the object, which is responsible for reading the member fields from the associated *Channel* object. The restored component objects can then be added to the *Domain* object. Figure 5.5 illustrates the process of invoking `recvSelf()` on a *Domain* object to restore its state to a specific step.

5.2.3 Sampling at a Specified Interval

We illustrate the usage of selective data storage strategies in this section by sampling the results at specified intervals (SASI). This data storage strategy can be applied for nonlinear incremental analysis. For numerical analysis of structures, formulation of equilibrium on the deformed geometry of a structure, together with nonlinear behavior of materials, will result in a system of nonlinear stiffness equations. One method for solving these equations is to approximate their non-linearity with a piecewise segmental fit [75]. For example, the single-step incremental method employs a strategy that is analogous to solving systems of linear or nonlinear differential equations by the Runge-Kutta methods. In general, the incremental analysis can be cast in the form

$$\{\Delta_i\} = \{\Delta_{i-1}\} + \{d\Delta_i\}$$

where $\{\Delta_{i-1}\}$ and $\{\Delta_i\}$ are the total displacements at the end of the previous and current load increments, respectively. The increment of unknown displacements $\{d\Delta_i\}$ is found in a single step by solving the linear system of equations

$$[\bar{K}_i]\{d\Delta_i\} = \{dP_i\}$$

where $[\bar{K}_i]$ and $\{dP_i\}$ represents the incremental stiffness and load respectively.

In contrast to the single-step schemes, the iterative methods need not use a single stiffness in each load increment. Instead, increments can be subdivided into a number of steps, each of which is a cycle in an iterative process aimed at satisfying the requirements of equilibrium within a specified tolerance. The displacement equation thus can be modified to

$$\{\Delta_i\} = \{\Delta_{i-1}\} + \sum_{j=1}^{m_i} \{d\Delta_i^j\}$$

where m_i is the number of iterative steps required in the i th load increment. In each step j , the unknown displacements are found by solving the linear system of equations

$$[K_i^{j-1}]\{d\Delta_i^j\} = \{dP_i^j\} + \{R_i^{j-1}\}$$

where $[K_i^{j-1}]$ is the stiffness evaluated using the deformed geometry and corresponding element forces up to and including the previous iteration, and $\{R_i^{j-1}\}$ represents the imbalance between the existing external and internal forces. This unbalanced load vector can be calculated according to

$$\{R_i^{j-1}\} = \{P_i^{j-1}\} - \{F_i^{j-1}\}$$

where $\{P_i^{j-1}\}$ is the total external force applied and $\{F_i^{j-1}\}$ is a vector of net internal forces produced by summing the existing element end forces at each global degree of freedom. Note that in the above equations, the subscript is used to indicate a particular increment and the superscript represents an iterative step.

From the above equations, it can be seen that the state of the domain at a certain step is only dependent on the state of the domain at the immediate previous step. This is applicable for both incremental single-step methods and some of the incremental-iterative methods (such as Newton-Raphson scheme). Based on this observation, a discrete storage strategy can be applied to nonlinear structural analysis. More specifically, instead of storing all the analysis results, the state information of a nonlinear analysis is saved at a specified interval (e.g. every 10 steps or other appropriate number of steps, instead of every step). The saved state information needs to be sufficient to restore the domain to that particular step. As discussed earlier, object serialization can be used to guarantee this requirement.

During the postprocessing phase, the data requests are forwarded from the remote client site to the analysis core. After receiving the requests, the analysis core will search the database to find the closest sampled point that is less than or equal to the queried step. The core then fetches the data from the database to obtain the necessary state information for that step. These fetched data will be sufficient to restore the domain to that sampled step. After the domain restores itself to the required step, the core can progress itself to

reach the queried time or incremental step. The details of this process are illustrated in the pseudo code shown in Figure 5.6. Once the state of the queried step is restored, the data queries regarding the domain at that step can be processed by calling the corresponding member functions of the restored domain objects. Since the domain state is only saved at the sampled steps, the total storage space is dramatically reduced as opposed to saving the domain state at all the steps. Compared with restarting the analysis from the original step, the processing time needed by using *SASI* (i.e. restarting the analysis from a sampled step) can potentially be reduced significantly. The same strategy can also be designed for other types of analyses (such as for time dependent problems).

```
Domain* convertToState(int requestStep, char* dbName,
                      double convergenceTest)
{
    Domain* theDomain = new Domain();
    FEM_ObjectBroker *theBroker = new FEM_ObjectBroker();
    DB_Datastore *database = new DB_Datastore(dbName,
                                             *theDomain, *theBroker);

    // Find the sampled largest time step that is <= requestStep.
    int savedStep = findMinMax(*database, requestStep);

    // The domain restores itself to the state of savedStep.
    theDomain->recvSelf(savedStep, *database, *theBroker);

    // The first parameter is dLamda, the second is numIncrements.
    Integrator *theIntegrator = new LoadControl(0.1, 10);
    SolutionAlgorithm *theAlgorithm =
        new NewtonRaphson(convergenceTest);

    // Set the links to theAlgorithm with theDomain and theIntegrator.
    theAlgorithm->setLinks(theDomain, theIntegrator);

    // Progress the state of theDomain to the requestStep.
    for (int i = savedStep, i < requestStep; i++) {
        theIntegrator->newStep();
        theAlgorithm->solveCurrentStep();
        theIntegrator->commit();
    }

    return *theDomain;
}
```

Figure 5.6: Pseudo Code for Converting the Domain State

5.3 Data Representation

In the data access system of the collaborative framework, data are organized internally within the FEA analysis core using an object-oriented model. Data saved in the COTS databases are represented in three basic data types: Matrix, Vector, and ID. Project management and version control capabilities are also supported by the system. For external data representation, XML (eXtensible Markup Language) [49] is chosen as the standard for representing data in a platform independent manner. Since the internal and external data representations are different, certain data translation mechanism is needed.

5.3.1 Data Modeling

The role of databases as repositories of information (data) highlighted the importance of data structures and data representation. Several general approaches for organizing the data models have been developed. They are: the hierarchical approach, the network approach, the relational approach, and the object-oriented approach. No matter which data model is used, data structures need to be self-describable [32]. The relational model was introduced by Codd [17] in 1970, and has been adopted in several finite element programs to represent the models and the analysis results [7, 102, 119].

In the collaborative framework, a relational COTS database system is used as the backend data management system. A relational database can be perceived by the users to be a collection of tables, with operators allowing a user to generate new tables and retrieve the data from the tables. The term *schema* often refers to a description of the tables and fields along with their relationships in a relational database system. An *entity* is any distinguishable object to be represented in the database. While at the conceptual level a user may perceive the database as a collection of tables, this does not mean that the data in the database is stored internally in tabular form. At the internal level, the data management system (DBMS) can choose the most suitable data structures necessary to

store the data. This allows the DBMS to look after issues such as disk seek time, disk rotational latency, transfer time, page size, and data placement to obtain a system which can respond to user requests much more efficiently than if the users were to implement the database directly using the file system.

The typical approach in using relational databases for FEA is to create a table for each type of object that needs to be stored (for example, see Reference [119]). This approach, while straightforward, would require that at least a table be created for each type of object in the domain. Furthermore, in nonlinear analysis, two tables would have to be created, one for the geometry and the other for the state information of a time step. Since data structures would grow with the incorporation of new element and material types for finite element analysis programs, the static schema definition of most DBMS is incompatible with the evolutionary nature of FEA software. The static schema definition of most COTS database systems makes them having difficulties in coping with changes and modification in the evolution of a FEA program – inconsistencies could be introduced into the database and they are expensive to eliminate.

Since OpenSees is designed and implemented using C++, the internal data structure is organized in an object-oriented fashion. The object-oriented data structure cannot be easily mapped into a relational database. As discussed in the last section, object serialization can be employed efficiently as linear stream to represent the internal state of an object. The linear stream can simply be a byte stream, or it can be a sequence of matrix-type data, namely ID (array of integers), Vector (array of real numbers), and Matrix. The byte stream can be stored in the database as a CLOB in order to achieve good performance for data storage and searching. A CLOB is a built-in type that stores a *Character Large Object Block* as an entity in a database table. Two methods `sendObj()` and `recvObj()` are provided in the interface of `DB_Datastore` for the storage and retrieval of byte streams. The matrix-type data (ID, Vector, and Matrix), on the other hand, can be directly stored in a relational database. The corresponding methods for accessing the matrix-type data are also provided in `DB_Datastore` interface.

In the current implementation of the online data access system, we focus on using the matrix-type data to represent and store the state of an object.

By using matrix-type data for storing object states, the database schema can be defined statically. The advantage of this approach is that new classes can be introduced to the analysis core without the creation of new tables in the relational database. The layer of abstraction provided by `DB_Datastore` can alleviate the burden of the FEA software developers, who in this case are typically finite element analysts, for learning database technologies. As long as a new class (new element, new material types, etc.) follows the protocols of implementing `sendSelf()` and `recvSelf()`, the objects of the new introduced class can communicate with the database through a `DB_Datastore` object. The disadvantage of this approach is that no information regarding the meaning of the data will exist within the database. Therefore, users cannot query the database directly to obtain analysis results, e.g. the maximum stress in a particular type of elements. However, as discussed early, the data can be retrieved from the database by the objects in the core that placed the data there; that is, the semantic information are embedded in the objects themselves.

5.3.2 Project-Based Data Storage

As shown in Figure 5.1, a database is provided as the backend data storage to facilitate online data access. Since potentially many users can access the core server to perform structural analysis and to query the analysis results, a project management scheme is needed. The basic premise is that most researchers and engineers typically work independently, while sharing information necessary for collaboration. More importantly, they wish to retain control over the information they make accessible to other members [56]. In the prototype online data access system, a mechanism to perform version control and access control in order to cope with project evolution is implemented. The overall database schema is depicted in Figure 5.7. The schema includes a `USER` table and a `PROJECT` table. A user is identified by name and a project is identified by both its name

and version. We use a hierarchical tree structure to maintain the version set of the projects. To simplify the design, each project has a primary user associated with it. This super-user has the privilege to modify the access control of a project. Only the authorized users who have the *write* permission of a project will be allowed to make changes on the project and to perform online simulation with the analysis model. Other registered users only have *read* permission, in that any manipulation of analysis data is to be done *a posteriori* (for example, using other external programs such as MATLAB). The access control information of a project is stored in the ACCESS_CTRL table.

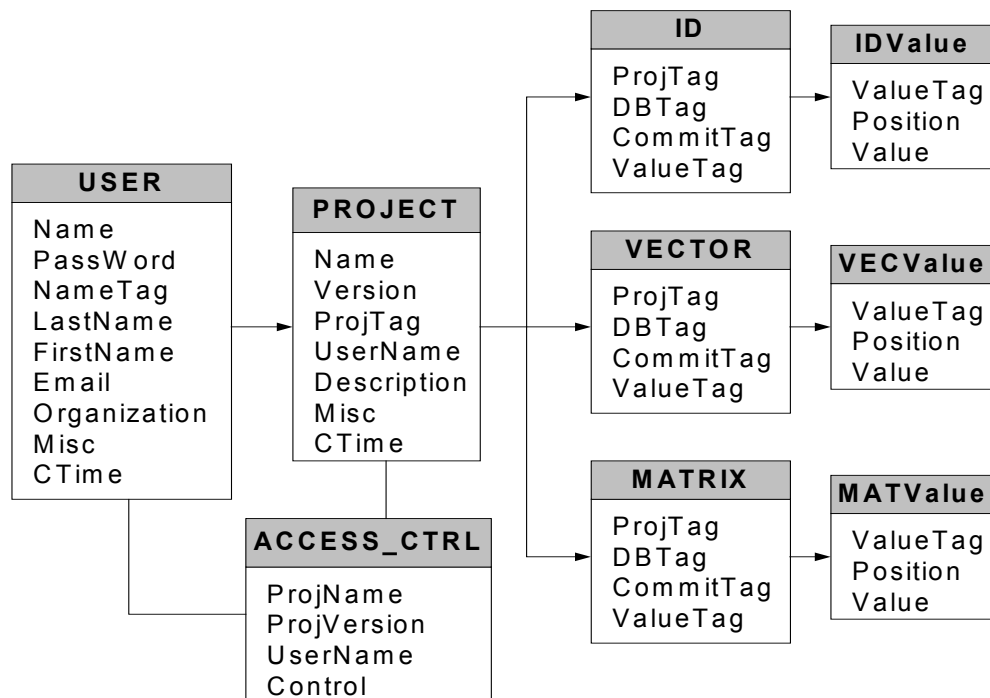

Figure 5.7: Database Schema Diagram for the Online Data Access System

For the storage of nonlinear dynamic simulation results of a typical project, a hybrid storage strategy is utilized. As mentioned early, the state information saved in the database follows the *SASI* strategy. The *SASI* strategy is very convenient and efficient for servicing the queries related to a certain time step, e.g. the displacement of Node 24 at

time step 462. For obtaining a response time history, on the other hand, using the state information alone to reconstruct the domain will not be efficient. This is because a response time history includes the results from all time steps, and thus constructing a response time history requires the state information from all time steps to be reconstructed. The performance of reconstructing all time steps could be as expensive as a complete re-analysis. To alleviate the performance penalty, the data access system has an option to allow the users to specify their interested response time histories in the input Tcl file. During the nonlinear dynamic simulation, these pre-defined response time histories will be saved in files together with certain description information. These response time history files can then be accessed directly during post-processing phase without involving expensive re-computation.

For the storage of Domain state information at the specified intervals, three tables are needed to store the basic data types. They are ID, VECTOR, and MATRIX. Figure 5.7 depicts the schema design of the database and the relations among different tables. For ID, VECTOR, and MATRIX tables, the attribute *projTag* identifies the project that an entry belongs to; *dbTag* is an internal generated tag to identify the data entry; and *commitTag* flags the time step. Together, the set of attributes (*projTag*, *dbTag*, *commiTag*) is used as an *index* for the database table. An index on a set of attributes of a relation table is a data structure that makes it efficient to find those tuples that have a fixed value for the set of attributes. When a relation table is very large, it becomes expensive to scan all the tuples of a relation to find those tuples that match a given condition. In this case, an index usually helps with queries in which their attribute is compared with a constant. This is the most frequently used case for the database queries.

5.3.3 Data Representation in XML

Software applications collaborate by exchanging information. For example, a finite element program needs to be able to obtain an analysis model from CAD programs and send the analysis results to design tools. The lack of a reliable, simple, and universally

deployed data exchange model has long impaired effective interoperations among heterogeneous software applications. The integration of scientific and engineering software is usually a complex programming task. Achieving data interoperability is often referred to as *legacy integration* or *legacy wrapping*, which has typically been addressed by *ad-hoc* means. There are several problems associated with the *ad-hoc* approach. First, every connection between two systems will most likely require custom programming. If many systems are involved, a lot of programming effort will be needed. Furthermore, if there are changes in the logic or data structures in one system, the interface will probably need to change – again, more need for programming. Finally, these interfaces are fragile: if some data are corrupted or parameters do not exactly match, unpredictable results can occur. Error handling and recovery are quite difficult with this approach.

XML (eXtensible Markup Language) [49] can alleviate many of these programming problems associated with data conversion. XML is a textual language quickly gaining popularity for data representation and exchange on the Web [42]. XML is a meta-markup language that consists of a set of rules for creating semantic tags used to describe data. An XML element is made up of a start tag, an end tag, and content in between. The start and end tags describe the content within the tags, which is considered the value of the element. In addition to tags and values, attributes are provided to annotate elements. Thus, XML files contain both data and structural information.

In the data access system, XML is adopted as the external data representation for exchanging data between collaborating applications. Since the internal data of OpenSees is organized in terms of matrix-type data (Matrix, Vector, and ID objects) and basic-type data (integer, real, and string, etc.), a mechanism to translate between internal data and external XML representation is needed. The translation is achieved by adding two services: matrix services and XML packaging services. The matrix services are responsible for converting matrix-type data into an XML element, while the XML

services can package both XML elements and basic-type data into XML files. The relation of these two types of services is shown in Figure 5.8.

The translation between matrix-type data (Matrix, Vector, and ID) and XML elements is achieved by adding two member functions to the Matrix, Vector, and ID classes to perform data conversion. These two new member functions are:

```
char* ObjToXML();
void XMLToObj(char* inputXML);
```

The function `XMLToObj()` is used to populate a matrix-type object with an input XML stream; and the function `ObjToXML()` is responsible for converting the object member data into XML representation. In order to represent data efficiently, matrix-type entity sets can be divided into two categories: sparse matrices and full matrices. Figure 5.9 shows the XML representation of a full matrix (for example, the stiffness matrix of a 2D truss element) and a sparse matrix (for example, the lumped mass matrix of a 2D truss element). Since Vector and ID are normally not sparse, they can be represented in a similar way as full matrix.

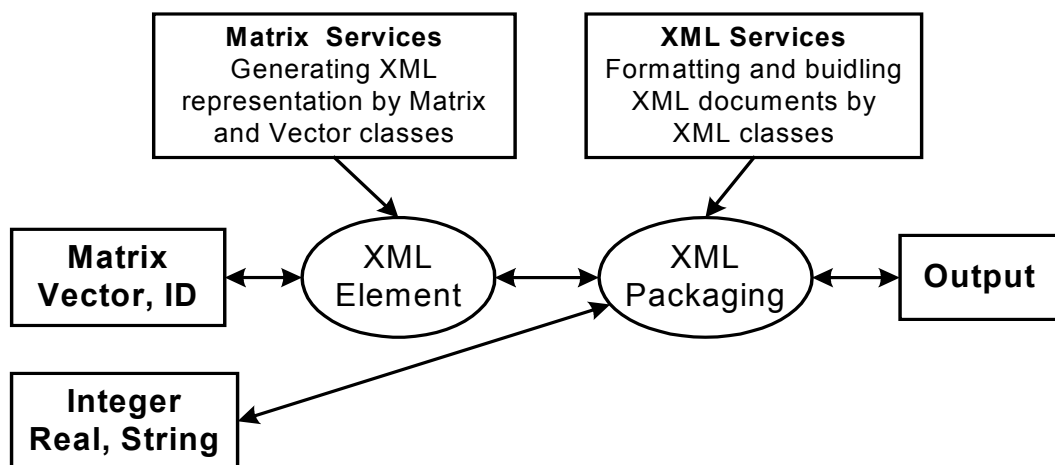

Figure 5.8: The Relation of XML Services

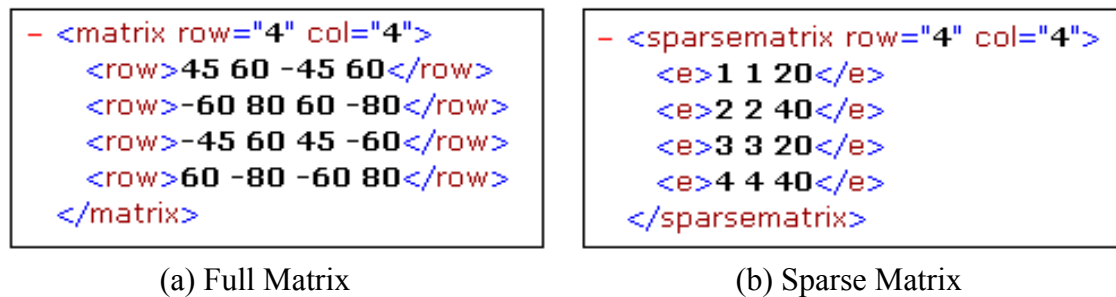

Figure 5.9: XML Representation of Matrix-Type Data

After matrix-type data are converted into XML elements, the next step is packaging them with other related information. This can be achieved by adding a new class **XMLService** to OpenSees, which is responsible for formatting and building XML documents, as well as interpreting and parsing input XML documents.

Two data models have been used in the data access system for XML representation. The *relational* model is used with tabular information, while the *list* model is defined for matrix-type entity sets. Because different mechanisms involved in locating a record of information, the relational model is different in implementation from the list model. The tabular data essentially has two parts, one is the metadata that is the schema definition and the other is the content. An example of the tabular data is the displacement time history response of a node in nonlinear analysis. The list model is essentially provided for packaging all the related information into a single XML file. An example of the list model is the description of an element. Figure 5.10 shows the example XML representations for both tabular data and list data.

<pre> - <DQL obj="node" num="19" dof="1"> - <table row="2" col="2"> - <metadata> - <column> <name>time</name> <unit>second</unit> </column> - <column> <name>disp</name> <unit>inch</unit> </column> </metadata> - <content> - <row> <e>1.00</e> <e>-0.002392</e> </row> - <row> <e>1.02</e> <e>-0.009775</e> </row> </content> </table> </DQL> </pre>	<pre> - <DQL obj="element" type="2Dtruss" num="2"> <area>5.0</area> <E>3000</E> <strain>-0.0003837</strain> <axialF>57.546</axialF> - <stiff> - <matrix row="4" col="4"> <row>45 60 -45 60</row> <row>-60 80 60 -80</row> <row>-45 60 45 -60</row> <row>60 -80 -60 80</row> </matrix> </stiff> - <mass> - <sparsematrix row="4" col="4"> <e>1 1 20</e> <e>2 2 40</e> <e>3 3 20</e> <e>4 4 40</e> </sparsematrix> </mass> </DQL> </pre>
--	--

(a) Tabular Data

(b) List Data

Figure 5.10: XML Representation of Packaged Data

5.4 Data Query Processing

For finite element programs, the post-processing functions need to allow the recovery of analysis results and provide extensive graphical and numerical tools for gaining an understanding of results. In this sense, querying the analysis results is an important aspect and query languages need to be constructed to retrieve the analysis results. In the online data access system, a data query processing system is provided to support the interaction with both humans and other application programs. A data query language is also defined to facilitate data retrieval as well as invoking post-processing functionalities.

With the query language, users can have uniform access to the analysis results by using a web-browser or other application programs.

5.4.1 Data Query Language

The data access system supports both programmed procedures and high-level query languages for accessing domain models and analysis results. A query language can be used to define, manipulate, and retrieve information from a database. For instance, for retrieving some particular result of an analysis, a query can be formed in the high-level and declarative query language that satisfies the specified syntax and conditions. In the data access system, a query language is provided to query the analysis result. The DQL (data query language) is defined in a systematic way and it is capable of querying the analysis results together with invoking certain post-processing computation. Combining general query language constructs with domain-related representations provides a more problem-oriented communication. [88]. The defined DQL and the programmed procedures have at least two features:

- It provides a unified data query language. No matter what kind of form the data is presented (whether a relation or a matrix), the data is treated in the same way. It is also possible to make query on specific entries in a table or individual elements of a matrix.
- The DQL language provides the same syntax for both terminal users (from command lines) and for those who use the DQL within a programmed procedure. This leads to the ease of communication between the client and the server, and can save programming efforts when linking the data access system with other application programs.

As discussed earlier, a hybrid storage strategy is utilized for storing nonlinear dynamic simulation results. For different type of stored data (results regarding a certain time step

or time history responses), different query commands are needed and different actions are taken. Several commonly used features of the DQL are illustrated below.

Queries related to a particular time step:

First, we will illustrate the queries related to a particular time step. In order to query the data related to a specified time step, the Domain state needs to be restored to that time step. For example, we can use command `RESTORE 462`, which will trigger the function `convertToState()` on the Domain object (shown in Figure 5.6) to restore domain state to time step 462.

After the domain has been restored to the time step, queries can be issued for detailed information. As an example, we can query the displacement from Node number 4,

```
SELECT disp FROM node=4;
```

The analysis result can also be queried from other domain object: Element, Constraint, and Load. For example,

```
SELECT tangentStiff FROM element=2;
```

returns the stiffness matrix of Element number 2.

Besides the general queries, two wildcards are provided. One is the wildcard `*` that represents *all values*. For instance, if we want to obtain the displacement from all the nodes, we can use

```
SELECT disp FROM node=*;
```

The other wildcard `?` can be used on certain object to find out what kind of queries it can support. For example, the following query

```
SELECT ? FROM node=1;
```

returns Node 1:: numDOF crds disp vel accel load mass *

Another class of operations is *aggregation*. By aggregation, we mean an operation that forms a single value from a list of related values. In the current implementation, five operators are provided that apply to a list of related values and produce a summary or aggregation of that list. These operators are:

- SUM, the sum of the values in the list;
- AVG, the average of values in the list;
- MIN, the least value in the list;
- MAX, the greatest value in the list;
- COUNT, the number of values in the list.

Queries for time history responses:

The second type of queries is used to access the pre-defined analysis results, especially the time history responses. The users are allowed to specify in the Tcl file what kind of information they want to keep track of. During the structural analysis, these pre-defined data are stored in files in the central server site. The files saved in the server can be queried and downloaded by the clients. The queried time history responses can be saved into files in the client site. The data in the files then can be retrieved for future post-processing applications. For instance, if we want to save the displacement time history response of a particular node, the following query can be issued to the server

```
SELECT time disp FROM node=1 AND dof=1
SAVEAS node1.out;
```

If the data are pre-defined in the Tcl input file and saved during the analysis phase, the query can return the corresponding saved analysis results. Otherwise, a complete re-computation is triggered to generate the requested time history response.

5.4.2 Data Query Interfaces

The collaborative framework can offer users access to the analysis core, as well as the associated supporting services via the Internet. One of the supporting services is to query analysis results. Users can compile their query in the client site and then submit it to the central server. After the server finishes the processing, queried results will return to the users in a pre-defined XML format. It is up to the client program to interpret the data and present the data in a specific format desirable to the users. In the prototype system, two types of data query interfaces are provided: a web-based interface and a MATLAB-based interface. This client-server computing environment forms a complete computing framework with a very distinct division of responsibilities. One benefit of this model is the transparency of software services. From a user's perspective, the user is dealing with a single service from a single point-of-entry – even though the actual data may be saved in the database or re-generated by the analysis core.

For the data access system, a standard World Wide Web browser is employed to provide the user interaction with the core platform. Although the use of a web browser is not mandatory for the functionalities of the data access system, using a standard browser interface leverages the most widely available Internet environment, as well as being a convenient means of quick prototyping. Figure 5.11 shows the interaction between the web-based client and the data access server. A typical data query transaction starts with the user supplying his/her data query intention in a web-based form. After the web-server receives the submitted form, it will extract the useful information and packaging it into a command that conforms to the syntax of the DQL. Then the command will be issued to the core analysis server to trigger the query of certain data from the database and to perform some re-computation by the analysis core. After the queried data is generated, it will be sent to the client and presented to the user as a web page.

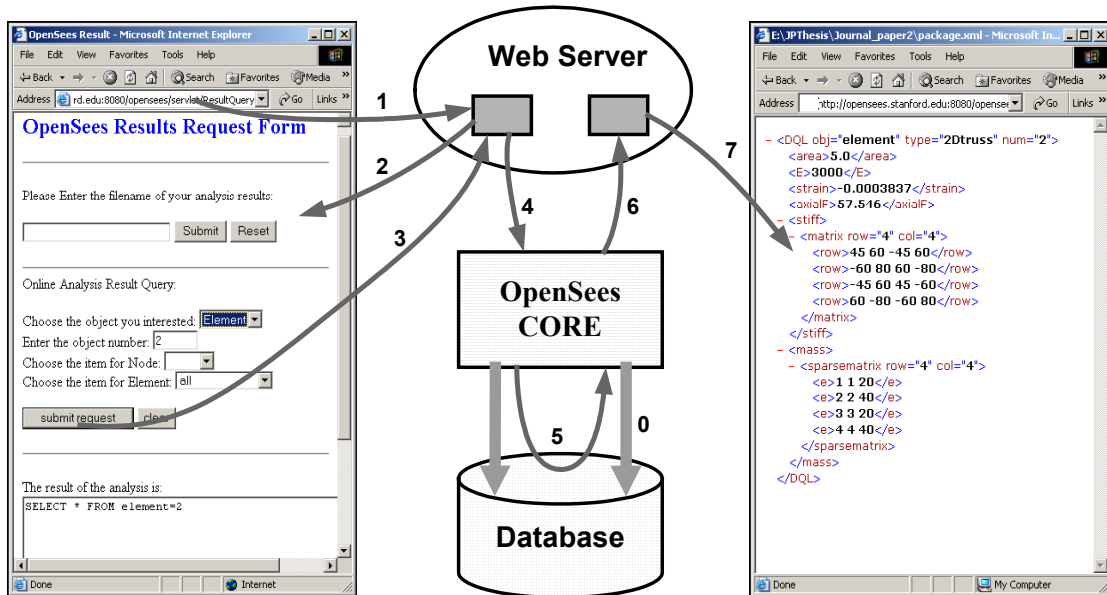

Figure 5.11: Interaction Diagram of Online Data Access System

The web-based client is convenient and straightforward for the cases when the volume of the queried data is small. When the data volume is big, especially if some post-processing is needed on the data, the direct usage of web-based client can bear some inconvenience. All too often the queried analysis results need to be downloaded from the server as a file, and then put manually into another program to perform post processing, e.g. a spreadsheet. For example, if we want to plot a time history response of a certain node after a dynamic analysis, we might have to download the response in a data file and then use MATLAB, Excel, or other software packages to generate the graphical representation. It would be more convenient to directly utilize some popular application software packages to enhance the interaction between client and server. In our prototype system, a MATLAB-based user interface is available to take advantage of the mathematical and graphical processing power of MATLAB. In the implementation, some extra functions are added to the standard MATLAB in order to handle the network communication and data processing. These add-on functions can be directly invoked from either the MATLAB prompt or a MATLAB-based graphical user interface.

5.5 Applications

A prototype of the online data access and project management system is implemented using Sun workstations as the hardware platform. The finite element analysis core is based on OpenSees, and the employed database system is Oracle 8i. Apache HTTP server is served as the web server, and Apache Tomcat 4.0 is utilized as the Java Servlet server. MATLAB 6.0 and a standard web-browser are employed as the user interfaces for accessing the analysis results and project-related information.

As we discussed earlier, a Tcl input interface is employed in OpenSees to send commands to the analysis core [77]. To facilitate data storage and data access, several new commands are introduced to the Tcl interpreter of OpenSees. The introduced new Tcl commands are:

- `database <databaseName> <databaseType>`

The `database` command is used to construct a `FE_Datastore` object to build the communication between OpenSees and a storage media. The first argument to the `database` command is `databaseName`, which can be used to specify the project that the simulation is related to. The second argument `databaseType` is used to specify the type of storage media. Some possible values for `databaseType` are: File, Oracle, MySQL, or other types of database systems.

- `save <startingStep> <endStep> <stepSize>`

The `save` command can be used to inform the Analysis object to save the domain state at certain time steps. The three arguments to the `save` commands are used to specify in which time steps the domain state needs to be saved. The `startingStep` defines the first time step the domain state is saved, the `endStep` defines the ending criteria, and the `stepSize` is the time interval. The usage of these three arguments is analogous to the usage of arguments in the `for` loop of C/C++ language.

- `restore <step>`

The `restore` command is used to restore the domain state to the specified time step `step`. If the domain state of the specified `step` is not saved in the database, certain re-computation will be triggered to restore the domain.

5.5.1 Example 1: Eighteen Story One Bay Frame Model

The first test case example is the eighteen story two-dimensional one bay frame model shown in Figure 3.8. For this example, the Newton-Raphson procedure is employed for the nonlinear structural analysis. Furthermore, the SASI strategy is used to store the domain state at every ten time steps. The step size (every 10 steps) is specified in the input Tcl file by using the `save` command. Besides the saved domain states, the time history displacement values of each node are saved in files by using the Tcl `recorder` command.

After the analysis, the results regarding any time step can be queried by using the DQL commands. The following illustrates example usage of some of the DQL commands. We use **C:** for the query command and **R:** for the queried results.

```
C: RESTORE 462
```

This command is used to restore the Domain state to the time step 462. The command first triggers the analysis core to fetch from the database the saved Domain state at time step 460, which is the closest time step stored before the requested step. The analysis core program then progresses itself to reach time step 462 using the Newton-Raphson scheme. After the Domain has been initialized to the step of 462, the wildcard ‘?’ can be used to find the attribute information of node 1 (which is the left node on the 18th floor) that can be retrieved:

```
C: SELECT ? FROM node=1;
```

```
R: Node 1:: numDOF crds disp vel accel load trialDisp
      trialVel trialAccel mass *
```

For example, we retrieve the displacement information of Node 1 as follows:

```
C: SELECT disp FROM node=1;
```

```
R: Node 1::
      disp= -7.42716  0.04044
```

The analysis result can also be queried for Element, Constraint, and Load. For instance, we can query the information related to element 19, which is the left column on the 18th floor.

```
C: SELECT ? FROM element=19;
```

```
R: ElasticBeam2D 19::
      connectedNodes A E I L tangentStiff secantStiff mass damp
```

```
C: SELECT L E FROM element=19;
```

```
R: ElasticBeam2D 19::
      L=144  E=29000
```

As mentioned earlier, five *aggregation* operators are provided to produce summary or aggregation information. For instance, the following command produces the maximum displacement among all the nodes. Note there that both positive and negative maximum values are presented.

```
C: SELECT MAX(disp) FROM node=*;
```

```
R: MAX(disp)::
      Node 1: -7.42716
      Node 21: 4.93986
```

We can also use a DQL command to query the time history response. For instance, if we want to save the displacement time history response of Node 1, the following query can be issued to the server

```
SELECT time disp FROM node=1 AND dof=1  
SAVEAS node1.out;
```

After the execution of the command, the displacement time history response of Node 1 is saved in a file named `node1.out`. At this stage, we can invoke the added MATLAB-based interface command `res2Dplot('node1.out')` to plot the displacement time history response of Node 1, which is shown in Figure 5.12.

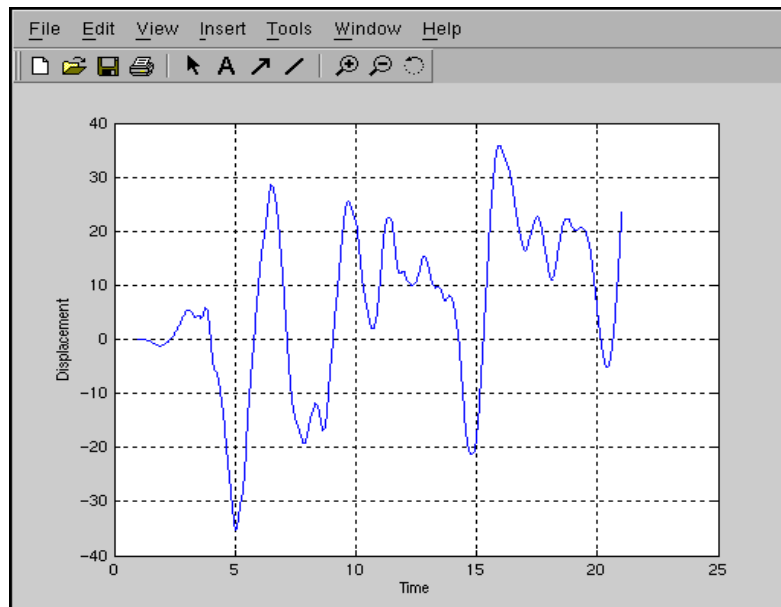
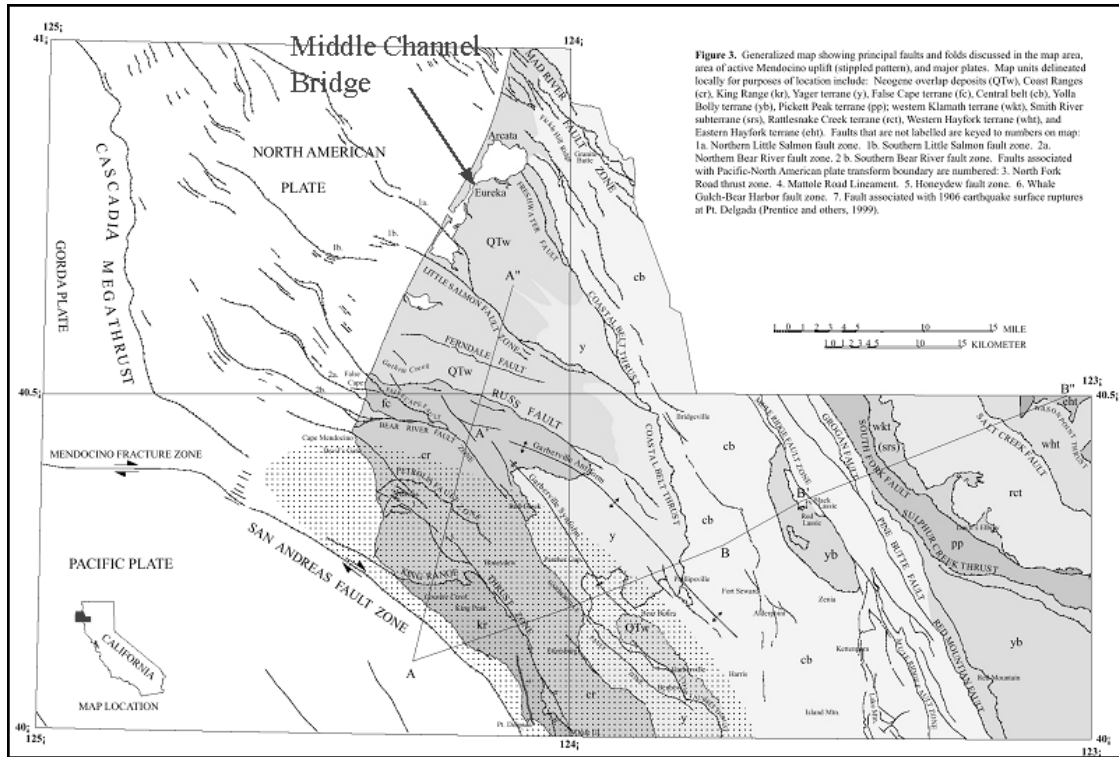

Figure 5.12: The Displacement Time History Response of Node 1

5.5.2 Example 2: Humboldt Bay Middle Channel Bridge Model

The second example is an ongoing research effort within the Pacific Earthquake Engineering Research (PEER) center to investigate the seismic performance of the Humboldt Bay Middle Channel Bridge. This is part of the PEER effort in developing probabilistic seismic performance assessment methodologies [20]. As shown in Figure 5.13(a), the Humboldt Bay Middle Channel Bridge is located at Eureka in northern California. This bridge (shown in Figure 5.13(b)) is a 330 meters long, 9-span composite structure with precast and prestressed concrete I-girders and cast-in-place concrete slabs to provide continuity. It is supported on eight pile groups, each of which consists of 5 to 16 prestressed concrete piles. Figure 5.14 shows the foundation condition for the bridge and a finite element model for the bridge. The river channel has an average slope from the banks to the center of about 7% (4 degrees). The foundation soil is mainly composed of dense fine-to-medium sand (SP/SM), organic silt (OL), and stiff clay layers. In addition, thin layers of loose and soft clay (OL/SM) are located near the ground surface. The bridge was designed in 1968 and built in 1971. The bridge has been the object of two Caltrans (California Department of Transportation) seismic retrofit efforts, the first one designed in 1985 and completed in 1987, and the second designed in 2001 to be completed in 2002.

A two-dimensional nonlinear model of the Middle Channel Bridge, including the superstructure, piers, and supporting piles, was developed using OpenSees as shown in Figure 5.14 [19]. The bridge piers are modeled using 2-D nonlinear material, fiber beam-column elements and the abutment joints are modeled using zero-length elasto-plastic gap-hook elements. A four-node quadrilateral element is used to discretize the soil domain. The soil below the water table is modeled as an undrained material, and the soil above as dry.



(a) Location of the Humboldt Bay Middle Channel Bridge

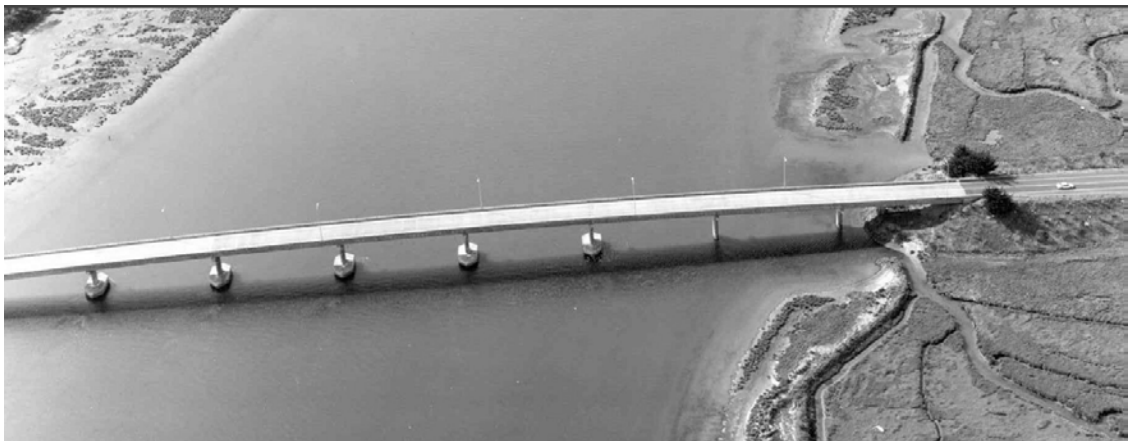

(b) Aerial Photograph of the Bridge

Figure 5.13: Humboldt Bay Middle Channel Bridge (Courtesy of Caltran)

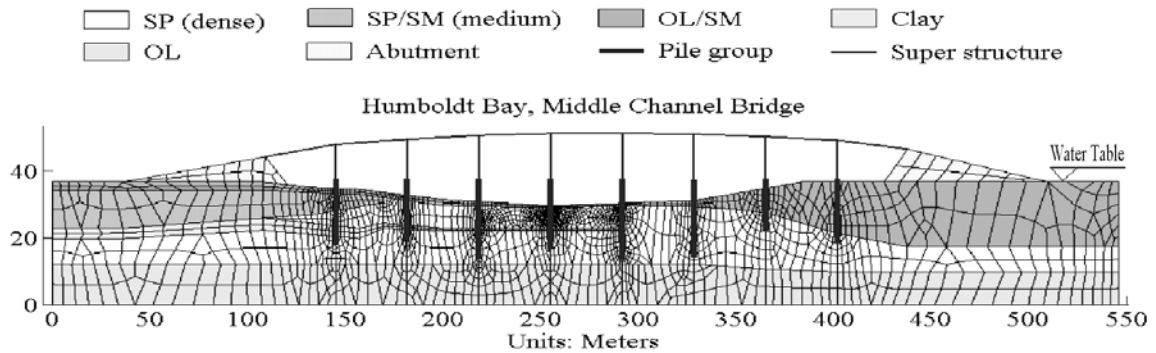

Figure 5.14: Finite Element Model for Humboldt Bay Bridge (from [19])

5.5.2.1 Project Management

In order to conduct probability analysis, approximately sixty ground motion records are to be applied to the bridge model for damage simulation. The ground motion records are divided into three hazardous levels based on their probability of occurrence, which are 2%, 10%, and 50% in fifty years respectively. Since the bridge will perform differently under each ground motion level, the projects can be grouped according to the applied ground motion records. Figure 5.15 is a list of some of the Humboldt Bay Bridge projects. When using the project management developed in this work, the web page is a single point-of-entry for all the project related background information, documents, messages, and simulation results. The detailed information of a particular project can be accessed by clicking on the project name, which is a hyperlink to the project website.

We will use project X1 (see Figure 5.15) as an illustration. The ground motion applied to this project is a near-field strong motion, the 1994 Northridge earthquake recorded at the Rinaldi station ($PGA = 0.89g$, $PGV = 1.85$ m/sec, $PGD = 0.60$ m), with a probability of 2% occurrence in fifty years. The earthquake record is shown in Figure 5.16. A nonlinear dynamic analysis is conducted on the model with the input ground motion.

The List of Current Projects:

ProjName	Version	UserName	Description	CTime	Message	Document
humboldt	X1	default	2% in 50 yrs (near field strong motion)	12-13-2001	Message	Doc
humboldt	X1.1	system	2% in 50 yrs	12-13-2001	Message	Doc
humboldt	X2	scott	2% in 50 yrs	12-19-2001	Message	Doc
humboldt	X3	system	2% in 50 yrs	1-14-2002	Message	Doc
humboldt	Y1	scott	10% in 50yrs	1-21-2002	Message	Doc
humboldt	Y2	default	10% in 50yrs	1-24-2002	Message	Doc
humboldt	Y2.1	system	10% in 50yrs	1-25-2002	Message	Doc
humboldt	Z1	default	50% in 50yrs	12-21-2002	Message	Doc
humboldt	Z2	default	50% in 50yrs	1-22-2002	Message	Doc

Figure 5.15: The List of Current Humboldt Bay Bridge Projects

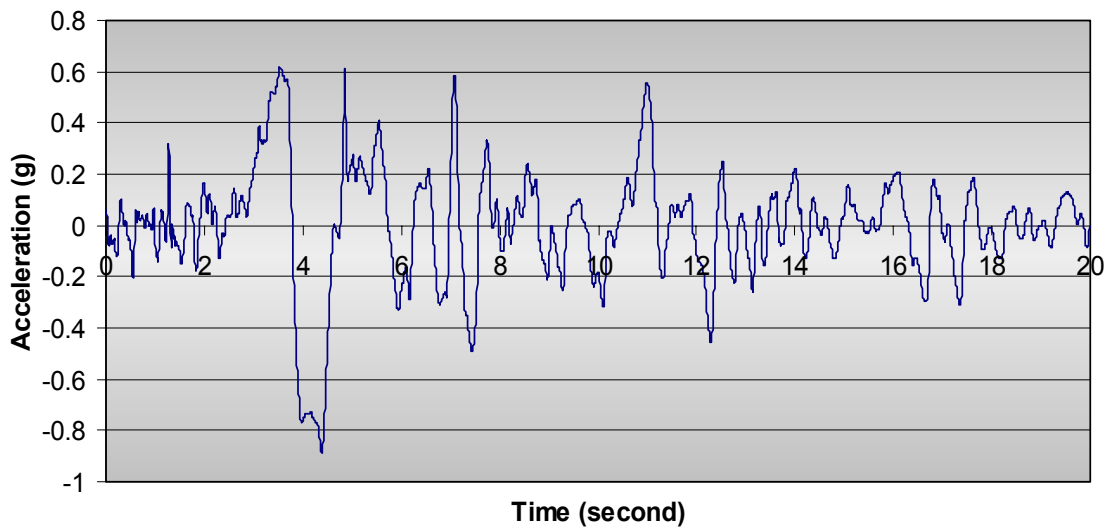

Figure 5.16: 1994 Northridge Earthquake Recorded at the Rinaldi Station

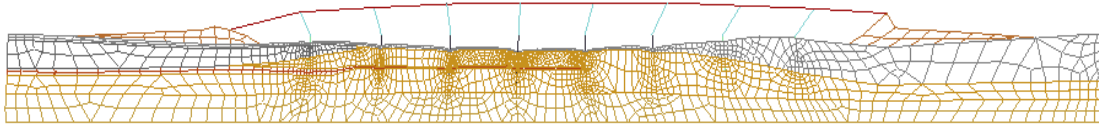

Figure 5.17: Deformed Mesh of Humboldt Bay Bridge Model (from [19])

After the nonlinear dynamic analysis is performed on the model, some generated results can be archived in the web server for sharing information. For example, Figure 5.17 shows the deformed mesh after the shaking event by applying the strong earthquake motion record. This figure is saved in the web server and can be accessed by following the link to the project. A main characteristic in this figure is that the abutments and riverbanks moved towards the center of the river channel. This is a direct consequence of the reduction in soil strength due to pore-pressure buildup.

5.5.2.2 Data Storage and Data Access

We have conducted a nonlinear dynamic analysis on the Humboldt Bay Bridge model. The analysis was conducted under three different conditions: without any domain state storage, using Oracle database to save the domain states at every 20 time steps, and using file system to save the domain states at every 20 time steps. The input earthquake record is the 1994 Northridge earthquake recorded at Rinaldi Station, as shown in Figure 5.16. Table 5.1 shows the solution time for the nonlinear dynamic analysis. Since the model is fairly large and some *expensive* elements (fiber element) and materials (nonlinear) are used in the model, the nonlinear dynamic analysis requires a significant amount of computational time. As shown in Table 5.1, the usage of Oracle database and file system to store the selected domain states further reduces the performance.

Table 5.1: Solution Time (in Minutes) for Nonlinear Dynamic Analysis

Time Steps	Analysis Time (mins)	Analysis Time (mins) (With Database)	Analysis Time (mins) (With Files)
100	262.6	321.6	314.5
500	1249.4	1663.8	1701.1
600	1437.3	1914.3	2026.7

Table 5.2: Solution Time (in Minutes) for Re-Computation

Time Steps	Analysis Time (mins)	Re-analysis Time (mins) (With Database)	Re-analysis Time (mins) (With Files)
105	281.7	39.4	46.9
539	1309.5	67.9	85.6
612	1464.8	55.7	71.4

Although there are performance penalties for using database or file system to save selected domain states during a nonlinear dynamic analysis, using the data storage can improve the performance of re-computation during the post-processing phase. Table 5.2 lists some solution time for re-computation that restores the domain to certain time steps. If there are no domain states archived during the analysis phase, we have to start the analysis again from the scratch, which can take a long time. On the other hand, with the selected domain states saved in the database or file system, we can restore the domain to certain stored state and then progress the domain to the requested time step. For example, in order to restore the domain state to the time step 105, we can retrieve the domain state at time step 100 and then progress the domain to time step 105 by using Newton-Raphson scheme. The solution time shown in Table 5.2 clearly demonstrated that the usage of data storage dramatically improves the performance of re-computation. The experimental results also showed that the usage of Oracle database is generally more efficient than the direct usage of file systems.

As mentioned earlier, a hybrid storage strategy is used to save some selected analysis results in the database during the nonlinear dynamic simulation. The saved analysis results include both Domain state information at sampled time steps and user pre-defined response time histories. To query results regarding a certain time step, the DQL commands are similar to what have been used for the previous example; and this process involves restoring the domain to that time step together with certain re-computation. For obtaining a pre-defined response time history, on the other hand, no re-computation is needed. Figure 5.18 shows a typical session using a web-based user interface, where all the pre-defined response time histories are listed, and the certain response results can be searched and downloaded.

Besides the web-based user interface, a MATLAB-based user interface is also available to take advantage of the mathematical manipulation and graphic display capabilities of MATLAB. Some functions are added to the standard MATLAB for handling the network communication and data processing. These commands can be executed from either the standard MATLAB prompt or the MATLAB-based graphical interfaces. We can issue the command `submitmodel humboldtX1.tcl` to submit the input file to the analysis core server for performing the online simulation. After the analysis, the command `queryresult` can be issued to bring up an interactive window. The user can enter DQL commands in this window to query the analysis results related to a certain time step. To access the pre-defined response time histories, the command `listResults` can be used to generate the list of response time history files (shown in Figure 5.19(a)). To generate a graphical representation of a particular response time history, two steps are needed: one for downloading the file and the other for plotting. For example, we can issue the command `getFile press1315_2.out` to download the response time history file and the command `res2Dplot('press1315_2.out')` to invoke the plotting of the results. The plot is shown in Figure 5.19(b).

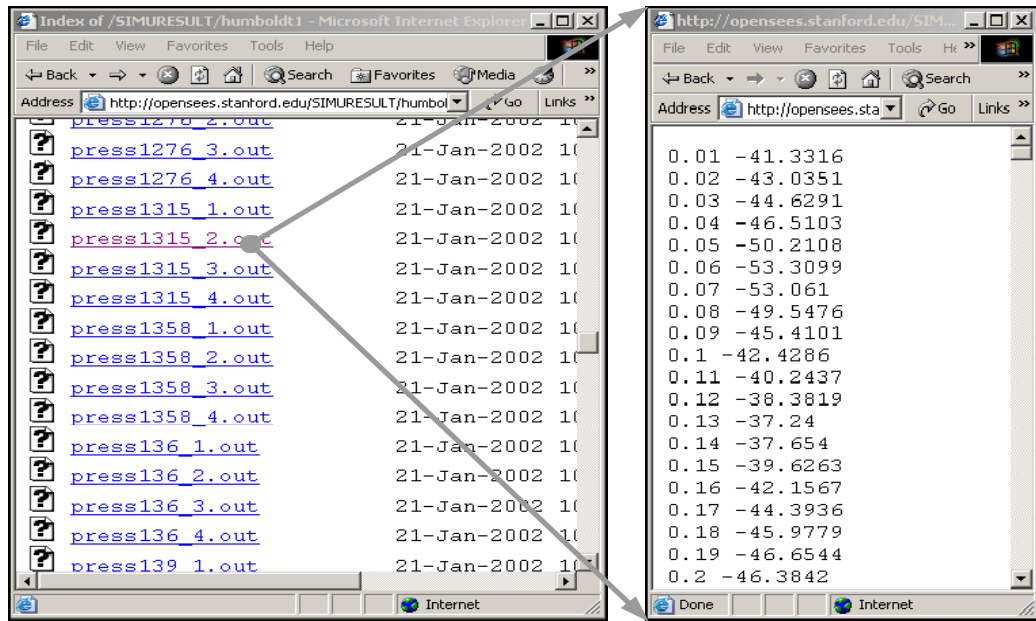

Figure 5.18: Web Pages of the Response Time Histories

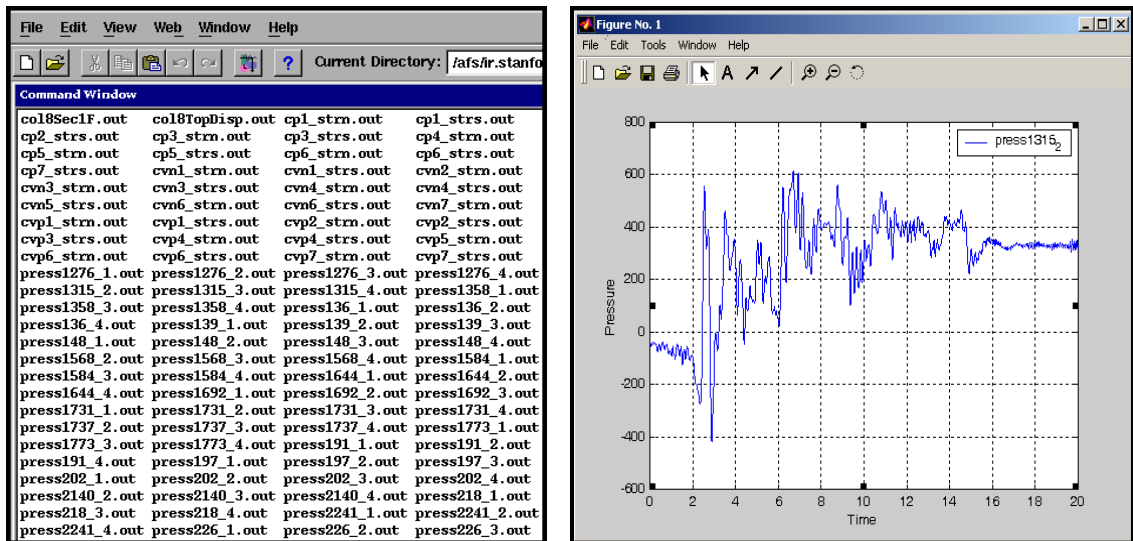

Figure 5.19: Sample MATLAB-Based User Interface

5.6 Summary and Discussion

Scientific and engineering database systems have several special requirements compared with their business counterparts. The dataflow of a finite element analysis program is tightly coupled with expensive numerical computation. This is one of the main reasons for the lack of a generic purpose data management system for finite element programs. When a number of programs are required for engineering simulation or design, the absence of standardization and the lack of coordination among software developers can result in difficulty in data communication from one program to another. The result is often manual transfer of data with laborious efforts, time delay, and potential error. In the effort of trying to alleviate some of the problems, we have introduced a data access system for a finite element structural analysis program. The main design principle of the system is to separate data access and data storage from data processing, so that each part of the system can be designed and implemented separately. By introducing a standard data representation and a modular infrastructure, each component of the system can be added or updated without substantial amount of modification to the existing system. By storing abstract data types (ID, Vector, and Matrix) into the database, it is not necessary to re-implement low-level dedicated data structures or to re-define new database tables for each added new element or other components. The utilization of standard query language and popular query interfaces, as well as the deployment of the Internet for delivering data, is another factor that makes the system flexible and extendible. Although this work has focused on data access system for a finite element program, the design principles and techniques can be applied to other similar types of engineering and scientific applications.

For the prototype implementation and testing in this research work, we have utilized Oracle database system as the backend data server. The experimental results clearly showed that a COTS database system can facilitate the data management for a FEA program, and improve the performance of certain types of queries including queries

related to a particular time step of a nonlinear dynamic analysis. Because the design is flexible and general, other types of database systems, e.g. MySQL [26], BerkeleyDB [85], or Microsoft Access [1], can be easily employed to provide data storage for the data access system.

In the prototype data access system, the performance may be a concern. This is partly because of the unstable performance of the Internet, and partly due to the design decision of sacrificing certain degree of performance for better flexibility and extendibility. However, compared with the direct usage of file systems, using relational database systems normally improves the overall performance of the system. By utilizing the selective storage strategy, especially SASI, the amount of storage space in our system is substantially smaller than the storage requirement of simply dumping all the analysis data into files. Compared to the traditional way of redoing the entire analysis to obtain the results that are not pre-defined, the re-computation technique used in the data access system could be more efficient because only a small portion of the program is executed with the goal to fulfill the query request. While the performance issue does exist, it may be alleviated by efficient optimization of generated code, and possibly, by indexing techniques. The database indexing techniques have been used in the prototype data access system to improve the performance of data query.

Chapter 6

Summary and Future Directions

This research has developed an Internet-enabled software framework and has proposed a new system paradigm for the design and implementation of finite element analysis programs. The framework allows distributed computers and related software components to function collaboratively as a single system. Three goals motivated the development of the collaborative software framework:

- Developing a software framework that would allow engineers and users to easily access a finite element analysis program running on server environment.
- Providing a *plug-and-play* environment where researchers and developers can collaborate and build incrementally on each other's developments.
- Providing a data management system to facilitate the access to simulation results and to perform project management.

This chapter provides a brief summary and discusses some key features of the collaborative software framework. Furthermore, certain limitations of the system and directions for future work are discussed.

6.1 Summary

This research is focused on the design and implementation of an Internet-enabled software framework that can facilitate the development of finite element analysis programs and the access of simulation results. The main design principle of this collaborative framework is to keep the software kernel flexible and extendible, so that a diverse group of users and developers can easily access the platform and attach their own developments to the core server. The collaborative Internet service architecture would allow new services to be remotely incorporated into a modular nonlinear dynamic analysis platform. Users can select appropriate services and can easily replace one service by another without having to recompile or reinitialize the existing services being used. The software framework also allows users to remotely access simulation results and other related information. There are a number of notable features of the collaborative software framework.

Component-based modular design is adopted in the collaborative framework to enhance the usability, flexibility, interoperability, and scalability of the engineering analysis software. The collaborative framework for the finite element structural analysis program described consists of six distinct components modules. Each module in the system is well-defined and encapsulated. In addition, each component module provides and/or requires a set of services interacting with the core via well-defined interfaces. The modules are “loosely coupled”, and the loose connectivity among components allows each component to be implemented separately, which can facilitate concurrent software development. For example, the engineering data access system is linked with the core server and employs a multi-tiered modular design, which separates data access and data storage from data processing. In short, the collaborative framework is a system where complex groupings of components can interact in diverse ways, and new components can easily be integrated to the system with a *plug-and-play* character. Another benefit of component-based design is that the code changes tend to be localized for the update and

improvement of the system. The localized code change can substantially reduce the efforts of integrating components and minimize the potential of bugs being introduced.

The research of the collaborative software framework focuses on the design and implementation of standardized interfaces and protocols. The standard interfaces are defined in the collaborative framework following the object-oriented design principles to facilitate local module integration. Standard communication protocols are also defined to allow different distributed and collaborative element services to participate in the system. Furthermore, this research has illustrated the ease of incorporating COTS (commercial off-the-shelf) software components and packages. In the collaborative framework, the user interfaces are based on COTS software such as web browsers and MATLAB. The database and the web server also use COTS software as building blocks.

The Internet is utilized in the software framework as a communication channel to link distributed software services and to access simulation results. The Internet has provided many possibilities for enhancing the distributive and collaborative software development and utilization. One important feature of the Internet-enabled framework is network transparency, which makes it indifferent to users whether code is running locally or remotely. The collaborative framework is based on a number of networking and communication technologies and the services are distributed over the Internet. The details of networking and data communication can be very complicated. Ideally, the distributed services need to be as self-configuring as possible so that the users do not need to bother with the technological details of the network. The collaborative framework provides an execution environment that users only deal with a single server. The end users do not need to be aware of the complexity of the core server in terms of both its hardware and software configurations.

The engineering data access and project management system is provided to manage simulation results and other pertinent information. This research has illustrated the usage of a database system that addresses some of the issues associated with traditional engineering data processing. A selective data storage scheme is introduced to provide

flexible support for the tradeoffs between the time used for reconstructing analysis domain and the space used for storing the analysis results. The data access system takes advantage of the nature of the object-oriented finite element core program to provide the semantics of the data objects. The data saved in the database system are represented in three basic data types; namely Matrix, Vector and ID, so that it is unnecessary to re-implement low-level dedicated data structures or to re-define new database tables for each added new element or object. The data access system also defines a data query language to support the interaction with both humans and other application programs. This research has introduced the potentials of using a project management system for archiving project-related information and performing access and revision control. The data access and project management system supports data storage transparency. Data storage transparency allows the users to choose the available and appropriate data storage media to save the analysis results. Since a standard interface is implemented to establish the communication between the analysis core and data storage media, the collaborative framework can interact with either file systems or commercial database systems. In other words, the implementation of the collaborative framework does not depend on the types of the storage media employed.

6.2 Future Directions

While this research has fulfilled its preliminary goals for a proof-of-concept development of a collaborative framework to facilitate the development and usage of a finite element analysis program, much new research and developments are needed to further enhance the robustness and functionalities of the software framework. The following enlists a selected few of the research tasks that worth future investigation.

Performance of the collaborative framework remains to be a key challenge for the wide adoption of the collaborative system for engineering practice. Although the distributed

service is a very convenient and flexible way of distributing computational tasks over a network, the performance penalty imposed by the distributed service is high. One avenue to improve the performance is to bundle the network communication, which is a method that would be able to reduce the cost associated with remote method initialization and network latency. The performance of the data access system may also be a concern. This performance penalty can be alleviated by efficient optimization of the generated code, and by employing appropriate indexing techniques.

Another limitation of the collaborative framework is the lack of authentication and security. Since the collaborative framework supports multiple software services and a great number of users, the authentication of these parties and the security of the communication are important to guarantee the integrity of the system. The collaborative framework already provides a simple mechanism to identify users and projects, and to enforce access control. Further consideration of the security issues needs to be addressed in the network level, especially by utilizing the Public Key Infrastructure (PKI) that supports digital signature and other public key-enabled security services [111].

The scalability of the collaborative system could be further improved. The current implementation relies on Java's multithreading feature to handle simultaneous requests from users. Test results showed that the performance might be substantially degraded when more than a dozen clients access the server simultaneously. This scalability problem could be tackled from both hardware and software. Multiple core servers and more powerful computers can be deployed; especially the locally distributed web-server systems are very promising to improve the performance and scalability [12]. Another possibility is to enhance the software framework by utilizing parallel and distributed computing environment [24, 71].

One of the goals of building distributed collaborative systems is to make the software system more reliable. The idea is that if a machine goes down, some other machines may take over the job. The approach for improving availability of the system is duplication and redundancy – key pieces of hardware and software should be replicated, so that if one

of them fails the others will be able to rescue the job. To achieve the goal of fault tolerance and fault recovery, a mechanism is needed to keep track of the state and progress of the analysis so that the simulation can continue and proper actions can be taken even if some computers are compromised [23].

Two user interfaces have been implemented in the current collaborative framework, namely the web-based interface and the MATLAB-based interface. These interfaces allow the users to remotely access the server to perform online simulation, and to query the analysis results by using the defined data query language. For the MATLAB-based user interface, this research focuses on network communication and data processing. Work should be continued to further explore the graphical manipulation power of MATLAB to provide better post-processing functionalities. Besides the web-based and the MATLAB-based interfaces, the core server can link with other software systems, such as Excel and other application programs.

The project management system developed in the collaborative framework allows the usage of a database system to manage the information related to projects. The actual project data is stored in distributed machines. Certain access control and revision control capabilities are provided in the project management system. Continuing developments are needed to improve the flexibility and functionalities of the project management system. One example is an automatic notification mechanism to acknowledge and notify the project participants whenever changes are happened to a particular project.

In conclusion, this research has developed a proof-of-concept prototype system that is capable of supporting collaborative development and usage of a finite element analysis program. The current functionalities of the Internet-enabled software framework have been demonstrated. The framework, which includes data and project management, provides the basic building blocks for further development. As discussed, continuing research and developments are needed to address the issues of performance, security, scalability, distributed and parallel computing, and others.

Bibliography

- [1] V. Andersen. *Access 2000: The Complete Reference*, 1st Ed., McGraw-Hill Osborne Media, Berkeley, CA, 1999.
- [2] E. Anderson, Z. Bai, C. Bischof, S. Blackford, J. Demmel, J. Dongarra, J. D. Croz, A. Greenbaum, S. Hammarling, A. McKenney, and D. Sorensen. *LAPACK Users' Guide*, 3rd Ed., Society for Industrial and Applied Mathematics (SIAM) Press, Philadelphia, PA, 1999.
- [3] C. J. Anumba. "Data Structures and DBMS for Computer-Aided Design Systems," *Advances in Engineering Software*, 25(2-3):123-129, 1996.
- [4] G. C. Archer. *Object-Oriented Finite Element Analysis*, Ph.D. Thesis, Department of Civil and Environmental Engineering, University of California, Berkeley, CA, 1996.
- [5] K. J. Bathe. *Finite Element Procedures*, 2nd Ed., Prentice Hall, Upper Saddle River, NJ, 1995.
- [6] A. D. Birrell and B. J. Nelson. "Implementing Remote Procedure Calls," *ACM Transactions on Computer Systems*, 2(1):39-59, 1984.

- [7] C. L. Blackburn, O. O. Storaasli, and R. E. Fulton. "The Role and Application of Data Base Management in Integrated Computer-Aided Design," *Journal of Aircraft*, 20(8):717-725, 1983.
- [8] F. Breg and C. D. Polychronopoulos. "Java Virtual Machine Support for Object Serialization," *Proceedings of the ISCOPE Conference on ACM 2001 Java Grande*, Palo Alto, CA, pp. 173-180, 2001.
- [9] F. Brezzi, K. J. Bathe, and M. Fortin. "Mixed-Interpolated Elements for Reissner-Mindlin Plates," *International Journal for Numerical Methods in Engineering*, 28(8):1787-1801, 1989.
- [10] T. A. Budd. *An Introduction to Object Oriented Programming*, 3rd Ed., Addison-Wesley, Boston, MA, 2002.
- [11] K. G. Budge and J. S. Peery. "RHALE: A MMALE Shock Physics Code Written in C++," *International Journal of Impact Engineering*, 14(1-4):107-120, 1993.
- [12] V. Cardellini, E. Casalicchio, M. Colajanni, and P. S. Yu. "The State of the Art in Locally Distributed Web-Server Systems," *ACM Computing Surveys*, 34(2):263-311, 2002.
- [13] A. Cardona, I. Klapka, and M. Geradin. "Design of a New Finite Element Programming Environment," *Engineering Computations*, 11(4):365-381, 1994.
- [14] M. J. Carey, D. J. DeWitt, G. Graefe, D. M. Haight, J. E. Richardson, D. T. Schuh, E. J. Skekita, and S. L. Vandenberg. *The EXODUS extensible DBMS project: An overview*, in *Readings in Object-Oriented Database Systems, Data Management Series*, S.B. Zdonik and D. Maier, Editors. Morgan Kaufmann, San Mateo, CA, 1990.
- [15] D. J. Carney and P. A. Oberndorf. "The Commandments of COTS: Still Searching for the Promised Land," *CrossTalk*, 10(5):25-30, 1997.

- [16] S. Chandra. "Information Extraction and Qualitative Descriptions from Dynamic Simulation Data," *Computers and Structures*, 69(6):757-766, 1998.
- [17] E. F. Codd. "A Relational Model of Data for Large Shared Data Banks," *Communications of the ACM*, 13(6):377-387, 1970.
- [18] S. Commend and T. Zimmermann. "Object-Oriented Nonlinear Finite Element Programming: A Primer," *Advances in Engineering Software*, 32(8):611-628, 2001.
- [19] J. P. Conte, A. Elgamal, Z. Yang, Y. Zhang, G. Acero, and F. Seible. "Nonlinear Seismic Analysis of a Bridge Ground System," *Proceedings of the 15th ASCE Engineering Mechanics Conference*, New York, NY, 2002.
- [20] A. Cornell and H. Krawinkler. "Progress and Challenges in Seismic Performance Assessment," *PEER Center News*, Spring 2000.
- [21] T. A. Davis. *A Column Pre-Ordering Strategy for the Unsymmetric-Pattern Multifrontal Method*, Technical Report TR-02-001, Computer & Information Science & Engineering, University of Florida, Gainesville, FL, 2002.
- [22] J. W. Demmel, S. C. Eisenstat, J. R. Gilbert, X. S. Li, and J. W. H. Liu. "A Supernodal Approach to Sparse Partial Pivoting," *SIAM Journal on Matrix Analysis and Applications*, 20(3):720-755, 1999.
- [23] E. De Santiago. *A Distributed Implementation of The Finite Element Method for Coupled Fluid Structure Problems*, Ph.D. Thesis, Department of Civil and Environmental Engineering, Stanford University, Stanford, CA, 1996.
- [24] E. De Santiago and K. H. Law. "A Distributed Implementation of an Adaptive Finite Element Method for Fluid Problems," *Computers and Structures*, 74(1):97-119, 2000.

- [25] S. M. Diwan. *Open HPC++: An Open Programming Environment for High-Performance Distributed Applications*, Ph.D. Thesis, Computer Science Department, Indiana University, Bloomington, IN, 1999.
- [26] P. DuBois and M. Widenius. *MySQL*, 1st Ed., New Riders Publishing, Indianapolis, IN, 1999.
- [27] Y. Dubois Pelerin and T. Zimmermann. "Object-Oriented Finite Element Programming: III. An efficient implementation in C++," *Computer Methods in Applied Mechanics and Engineering*, 108(1-2):165-183, 1993.
- [28] G. Eddon and H. Eddon. *Inside Distributed COM*, 1st Ed., Microsoft Press, Redmond, WA, 1998.
- [29] T. Ericsson and A. Ruhe. "The Spectral Transformation Lanczos Method for the Numerical Solution of Large Sparse Generalized Symmetric Eigenvalue Problems," *Mathematics of Computation*, 35(152):1251-1268, 1980.
- [30] D. Eyheramendy and T. Zimmermann. "Object-Oriented Finite Element Programming: Beyond Fast Prototyping," *Proceedings of the 2nd International Conference on Computational Structures Technology*, Athens, GA, pp. 121-128, 1994.
- [31] J. Farley. *Java Distributed Computing*, 1st Ed., O'Reilly & Associates, Sebastopol, CA, 1998.
- [32] C. A. Felippa. "Database Management in Scientific Computing -- I. General Description," *Computers and Structures*, 10(1-2):53-61, 1979.
- [33] C. A. Felippa. "Database Management in Scientific Computing -- II. Data Structures and Program Architecture," *Computers and Structures*, 12(1):131-146, 1980.

- [34] C. A. Felippa. "Database Management in Scientific Computing -- III. Implementation," *Proceedings of Symposium on Trends and Advances in Structural Mechanics*, Washington, DC, 1982.
- [35] P. A. Fishwick and C. L. Blackburn. "Managing Engineering Data Bases: The Relational Approach," *Computers in Mechanical Engineering*, 1(3):8-16, 1983.
- [36] B. W. R. Forde, R. O. Foschi, and S. F. Stiemer. "Object-Oriented Finite Element Analysis," *Computers and Structures*, 34(3):355-374, 1990.
- [37] I. Foster, C. Kesselman, G. Tsudik, and S. Tuecke. "A Security Architecture for Computational Grids," *Proceedings of the 5th ACM Conference on Computer and Communications Security*, pp. 83-92, 1998.
- [38] I. Foster, C. Kesselman, and S. Tuecke. "The Anatomy of the Grid: Enabling Scalable Virtual Organizations," *International Journal of Supercomputer Applications and High Performance Computing*, 15(3):200-222, 2001.
- [39] A. George. *Computer Implementation of the Finite Element Method*, Ph.D. Thesis, Computer Science Department, Stanford University, Stanford, CA, 1971.
- [40] A. George and J. W. Liu. *Computer Solution of Large Sparse Positive Definite Systems*, Prentice Hall, Englewood Cliffs, NJ, 1981.
- [41] A. George and J. W. Liu. "The Evolution of the Minimum Degree Ordering Algorithm," *SIAM Review*, 31(1):1-19, 1989.
- [42] R. Goldman, J. McHugh, and J. Widom. "From Semistructured Data to XML: Migrating the Lore Data Model and Query Language," *Proceedings of WebDB '99: the Second International Workshop on the Web and Databases*, Philadelphia, PA, pp. 25-30, 1999.

- [43] G. H. Golub and C. F. Van Loan. *Matrix Computations*, 3rd Ed., The Johns Hopkins University Press, Baltimore, MA, 1996.
- [44] J. Goodwill. *Apache Jakarta-Tomcat*, 1st Ed., APress, Berkeley, CA, 2001.
- [45] R. G. Grimes, J. G. Lewis, and H. D. Simon. "A Shifted Block Lanczos Algorithm for Solving Sparse Symmetric Generalized Eigenproblems," *SIAM Journal of Matrix Analysis and Applications*, 15(1):228-272, 1994.
- [46] C. S. Han, J. C. Kunz, and K. H. Law. "Building Design Services in A Distributed Architecture," *Journal of Computing in Civil Engineering*, 13(1):12-22, 1999.
- [47] M. Henning and S. Vinoski. *Advanced CORBA Programming with C++*, 1st Ed., Addison-Wesley, Boston, MA, 1999.
- [48] T. J. R. Hughes. *The Finite Element Method: Linear static and dynamic finite element analysis*, 1st Ed., Prentice Hall, Englewood Cliffs, NJ, 1987.
- [49] D. Hunter, J. Rafter, J. Pinnock, C. Dix, K. Cagle, and R. Kovack. *Beginning XML*, 2nd Ed., Wrox Press Inc, Chicago, IL, 2001.
- [50] J. Hunter and W. Crawford. *Java Servlet Programming*, 2nd Ed., O'Reilly & Associates, Sebastopol, CA, 2001.
- [51] J. Ju and M. U. Hosain. "Substructuring Using the Object-Oriented Approach," *Proceedings of the Second International Conference on Computational Structures Technology*, Athens, GA, pp. 115-120, 1994.
- [52] G. Karypis and V. Kumar. *METIS Version 4.0: A Software Package For Partitioning Unstructured Graphs, Partitioning Meshes, and Computing Fill-Reducing Orderings of Sparse Matrices*, Department of Computer Science and Engineering, University of Minnesota, Minneapolis, MN, 1998.

- [53] G. Karypis and V. Kumar. "A Fast and High Quality Multilevel Scheme for Partitioning Irregular Graphs," *SIAM Journal on Scientific Computing*, 20(1):359-392, 1998.
- [54] G. Karypis and V. Kumar. "Multilevel k-way Partitioning Scheme For Irregular Graphs," *Journal for Parallel and Distributed Computing*, 48(1):96-129, 1998.
- [55] X. A. Kong and D. P. Chen. "An Object-Oriented Design of FEM Programs," *Computers and Structures*, 57(1):157-166, 1995.
- [56] K. Krishnamurthy. *A Data Management Model for Change Control in Collaborative Design Environments*, Ph.D. Thesis, Department of Civil and Environmental Engineering, Stanford University, Stanford, CA, 1996.
- [57] T. Kyte. *Expert One on One: Oracle*, 1st Ed., Wrox Press, Chicago, IL, 2001.
- [58] C. L. Lawson, R. J. Hanson, D. R. Kincaid, and F. T. Krogh. "Basic Linear Algebra Subprograms for Fortran Usage," *ACM Transactions on Mathematical Software*, 5(3):308-323, 1979.
- [59] R. B. Lehoucq, D. C. Sorensen, and C. Yang. *ARPACK User's Guide: Solution of Large Scale Eigenvalue Problems by Implicitly Restarted Arnoldi Methods*, 1st Ed., Center for Research on Parallel Computation, Rice University, Houston, TX, 1997.
- [60] S. M. Lewandowski. "Frameworks for Component-Based Client/Server Computing," *ACM Computing Surveys*, 30(1):3-27, 1998.
- [61] S. Liang. *Java Native Interface: Programmer's Guide and Specification*, 1st Ed., Addison-Wesley, Boston, MA, 1999.
- [62] R. J. Lipton, D. J. Rose, and R. E. Tarjan. "Generalized Nested Dissection," *SIAM Journal on Numerical Analysis*, 16(1):346-358, 1979.

- [63] J. W. H. Liu. "A Compact Row Storage Scheme for Cholesky Factors Using Elimination Trees," *ACM Transactions on Mathematical Software*, 12(2):127-148, 1986.
- [64] J. W. H. Liu. "A Generalized Envelope Method for Sparse Factorization by Rows," *ACM Transactions on Mathematical Software*, 17(1):112-129, 1991.
- [65] J. Lu, D. W. White, W. F. Chen, H. E. Dunsmore, and E. D. Sotelino. "FE++: An Object-Oriented Application Framework for Finite Element Programming," *Proceedings of the Second Annual Object-Oriented Numerics Conference*, Sunriver, OR, pp. 438-447, 1994.
- [66] J. Lu, D. W. White, W. F. Chen, and H. E. Dunsmore. "A Matrix Class Library in C++ for Structural Engineering Computing," *Computers and Structures*, 55(1):95-111, 1995.
- [67] T. F. Lunney and A. J. McCaughey. "Component based distributed systems -- CORBA and EJB in context," *Computer Physics Communications*, 127(2-3):207-214, 2000.
- [68] A. MacBride, J. Susser, and K. Piersol. *Byte Guide to OpenDoc*, 1st Ed., McGraw-Hill Osborne, Berkeley, CA, 1996.
- [69] D. R. Mackay, K. H. Law, and A. Raefsky. "An Implementation of a Generalized Sparse/Profile Finite Element Solution Method," *Computers and Structures*, 41(4):723-737, 1991.
- [70] D. R. Mackay. *Solution Methods for Static and Dynamic Structural Analysis*, Ph.D. Thesis, Department of Civil and Environmental Engineering, Stanford University, Stanford, CA, 1992.

- [71] D. R. Mackay and K. H. Law. "A Parallel Implementation of a Generalized Lanczos Procedure for Structural Dynamic Analysis," *International Journal of High Speed Computing*, 8(2):171-204, 1996.
- [72] R. I. Mackie. "Object-Oriented Programming of the Finite Element Method," *International Journal for Numerical Methods in Engineering*, 35(2):425-436, 1992.
- [73] R. I. Mackie. "Object-Oriented Methods -- Finite Element Programming and Engineering Software Design," *Proceedings of the 6th International Conference on Computing in Civil and Building Engineering (ICCCBE-VI)*, Berlin, Germany, pp. 133-138, 1995.
- [74] R. I. Mackie. "Using Objects to Handle Complexity in Finite Element Software," *Engineering with Computers*, 13(2):99-111, 1997.
- [75] W. McGuire, R. H. Gallagher, and R. D. Ziemian. *Matrix Structural Analysis*, 2nd Ed., John Wiley & Sons, New York, NY, 2000.
- [76] F. McKenna. *Object-Oriented Finite Element Programming: Frameworks for Analysis, Algorithm and Parallel Computing*, Ph.D. Thesis, Department of Civil and Environmental Engineering, University of California at Berkeley, Berkeley, CA, 1997.
- [77] F. McKenna and G. L. Fenves. *The OpenSees Command Language Manual*, <http://opensees.berkeley.edu/OpenSees/OpenSeesCommands.pdf>, 2001.
- [78] F. McKenna. *OpenSees: Open System for Earthquake Engineering Simulation*, <http://opensees.berkeley.edu>, 2002.
- [79] P. Mentrey and T. Zimmermann. "Object-Oriented Non-linear Finite Element Analysis: Application to J2 Plasticity," *Computers and Structures*, 49(5):767-773, 1993.

- [80] Microsoft Corporation. *Dynamic Link Libraries: MSDN Library*, <http://msdn.microsoft.com/library/>, 2002.
- [81] G. R. Miller. "An Object-Oriented Approach to Structural Analysis And Design," *Computers and Structures*, 40(1):75-82, 1991.
- [82] R. N. Nagel, W. W. Braithwaite, and P. R. Kennicott. *Initial Graphics Exchange Specification IGES, Version 1.0*, National Bureau of Standards, Washington, DC, 1980.
- [83] J. Norton. "Dynamic Class Loading for C++ on Linux," *Linux Journal*, Issue 73, <http://www.linuxjournal.com/>, 2000.
- [84] H. Ohtsubo, Y. Kawamura, and A. Kubota. "Development of the Object-Oriented Finite Element Modelling System -- Modify," *Engineering with Computers*, 9(4):187-197, 1993.
- [85] M. A. Olson, K. Bostic, and M. Seltzer. "Berkeley DB," *Proceedings of the FREENIX Track: 1999 USENIX Annual Technical Conference*, Monterey, CA, pp. 183-192, 1999.
- [86] S. R. Ones and E. De Santiago. "An Object Based Application of Distributed Programming for Turbulent Flow Problems," *Proceedings of the ASCE Fourteenth Engineering Mechanics Conference*, Austin, TX, 2000.
- [87] R. Orfali and D. Harkey. *Client/Server Programming with Java and CORBA*, 2nd Ed., John Wiley & Sons, Hoboken, NJ, 1998.
- [88] K. Orsborn. "Applying Next Generation Object-Oriented DBMS for Finite Element Analysis," *Proceedings of the first International Conference on Applications of Databases (ADB'94)*, Vadstena, Sweden, pp. 215-233, 1994.

- [89] W. Ostermann, W. Wunderlich, and H. Cramer. "Object-Oriented Tools for the Development of User Interfaces for Interactive Teachware," *Proceedings of the Sixth International Conference on Computing in Civil and Building Engineering (ICCCBE-VI)*, Berlin, Germany, pp. 169-175, 1995.
- [90] R. Otte, P. Patrick, and M. Roy. *Understanding CORBA*, 1st Ed., Prentice Hall, Upper Saddle River, NJ, 1996.
- [91] J. K. Ousterhout. *Tcl and the Tk Toolkit*, 1st Ed., Addison-Wesley, Boston, MA, 1994.
- [92] M. Page Jones. *Fundamentals of Object-Oriented Design in UML*, Addison-Wesley, Boston, MA, 1999.
- [93] J. Peng and K. H. Law. "Framework for Collaborative Structural Analysis Software Development," *Proceedings of the Structural Congress & Expositions ASCE*, Philadelphia, PA, 2000.
- [94] J. Peng, F. McKenna, G. L. Fenves, and K. H. Law. "An Open Collaborative Model for Development of Finite Element Program," *Proceedings of the Eighth International Conference on Computing in Civil and Building Engineering (ICCCBE-VIII)*, Palo Alto, CA, pp. 1309-1316, 2000.
- [95] J. Peng and K. H. Law. "A Prototype Software Framework for Internet-Enabled Collaborative Development of a Structural Analysis Program," *Engineering with Computers*, 18(1):38-49, 2002.
- [96] J. Peng, D. Liu, and K. H. Law. "An Engineering Data Access System for a Finite Element Program," *Advances in Engineering Software (accepted for publication)*, 2002.
- [97] R. M. V. Pidaparti and A. V. Hudli. "Dynamic Analysis of Structures Using Object-Oriented Techniques," *Computers and Structures*, 49(1):149-156, 1993.

- [98] E. Pitt and K. McNiff. *java^(TM).rmi: The Remote Method Invocation Guide*, 1st Ed., Addison-Wesley, Boston, MA, 2001.
- [99] F. Plasil, S. Visnovsky, and M. Besta. "Bounding Component Behavior via Protocols," *Proceedings of TOOLS USA 1999: the 30th International Conference & Exhibition*, Santa Barbara, CA, pp. 387-398, 1999.
- [100] A. Pope. *The CORBA Reference Guide: Understanding the Common Object-Request Broker Architecture*, 1st Ed., Addison-Wesley, Boston, MA, 1998.
- [101] G. S. Raj. *A Detailed Comparison of CORBA, DCOM, and Java/RMI (with detailed code examples)*, Object Management Group (OMG) whitepaper, <http://www.omg.org/news/whitepapers/index.htm>, 1998.
- [102] S. D. Rajan and M. A. Bhatti. "SADDLE: A Computer-Aided Structural Analysis and Dynamic Design Language -- Part II. Database Management System," *Computers and Structures*, 22(2):205-212, 1986.
- [103] M. D. Rucki and G. R. Miller. "A Program Architecture for Interactive Nonlinear Dynamic Analysis of Structures," *Proceedings of the Fifth International Conference on Computing in Civil and Building Engineering (ICCCBE-V)*, Anaheim, CA, 1993.
- [104] M. D. Rucki and G. R. Miller. "Algorithmic Framework for Flexible Finite Element-Based Structural Modeling," *Computer Methods in Applied Mechanics and Engineering*, 136(3-4):363-384, 1996.
- [105] J. Rumbaugh, M. R. Blaha, W. Premerlani, F. Eddy, and W. Lorensen. *Object-Oriented Modeling and Design*, Prentice-Hall, Englewood Cliffs, NJ, 1991.
- [106] Y. Saad. *SPARSKIT: A Basic Tool Kit for Sparse Matrix Computations*, Technical Report CSRD TR 1029, Center for Supercomputing Research and Development, University of Illinois, Urbana-Champaign, IL, 1990.

- [107] S. P. Scholz. "Elements of an Object-Oriented FEM++ program in C++," *Computers and Structures*, 43(3):517-529, 1992.
- [108] E. J. Silva, R. C. Mesquita, R. R. Saldanha, and P. F. M. Palmeira. "An Object-Oriented Finite Element Program for Electromagnetic Field Computation," *IEEE Transactions on Magnetics*, 30(5):3618-3621, 1994.
- [109] A. Slominski, M. Govindaraju, D. Gannon, and R. Bramley. "Design of an XML based Interoperable RMI System: SoapRMI C++/Java 1.1," *Proceedings of PDPTA'2001: the International Conference on Parallel and Distributed Processing Techniques and Applications*, Las Vegas, NV, pp. 1661-1667, 2001.
- [110] B. L. Smith, and Scherer, W. T. "Developing Complex Integrated Computer Applications and Systems," *Journal of Computing in Civil Engineering*, 13(4):238-245, 1999.
- [111] W. Stallings. *Cryptography and Network Security: Principles and Practice*, 2nd Ed., Prentice Hall, Upper Saddle River, NJ, 1998.
- [112] B. Stearns. *The Java Tutorial: Java Native Interface*, <http://java.sun.com/docs/books/tutorial/native1.1/index.html/>, 2002.
- [113] B. Stroustrup. *The C++ Programming Language*, 3rd Ed., Addison-Wesley, Boston, MA, 2000.
- [114] Sun Microsystems. *Introduction to Sun Workshop: Forte Developer 6 Update 2*, Sun Microsystems, Inc., Palo Alto, CA, 2001.
- [115] The Mathworks Inc. *MATLAB The Language of Technical Computing: External Interfaces, Version 6*, Mathworks, Natick, MA, 2001.

- [116] W. F. Tinney and J. W. Walker. "Direct Solutions of Sparse Network Equations by Optimally Ordered Triangular Factorization," *Proceedings of the IEEE*, 55(11):1801-1809, 1967.
- [117] R. Van Engelen, K. Gallivan, G. Gupta, and G. Cybenko. "XML-RPC Agents for Distributed Scientific Computing," *Proceedings of IMACS'2000: the IMACS World Congress on Scientific Computation, Applied Mathematics and Simulation*, Lausanne, Switzerland, 2000.
- [118] P. Wegner. "Dimensions of Object-Based Language Design," *Proceedings of the Conference on Object Oriented Programming, Systems, Languages, and Applications (OOPSLA)*, Orlando, FL, pp. 168-182, 1987.
- [119] X. Yang. "Database Design Method for Finite Element Analysis," *Computers and Structures*, 44(4):911-914, 1992.
- [120] G. W. Zeglinski, R. S. Han, and P. Aitchison. "Object-Oriented Matrix Classes for Use in a Finite Element Code Using C++," *International Journal for Numerical Methods in Engineering*, 37(22):3921-3937, 1994.
- [121] T. Zimmermann, Y. Dubois Pelerin, and P. Bomme. "Object-Oriented Finite Element Programming: I. Governing Principles," *Computer Methods in Applied Mechanics and Engineering*, 98(2):291-303, 1992.