

Reliable information management in a low-cost wireless structural monitoring and control network

Yang Wang ^{*a}, Jerome P. Lynch ^b, Kincho H. Law ^a, Chin-Hsiung Loh ^c, Ahmed Elgamal ^d

^a Dept. of Civil and Environmental Engineering, Stanford Univ., Stanford, CA 94305

^b Dept. of Civil and Environmental Engineering, Univ. of Michigan, Ann Arbor, MI 49109

^c Dept. of Civil Engineering, National Taiwan Univ., Taipei, Taiwan, 106 R.O.C.

^d Dept. of Structural Engineering, Univ. of California at San Diego, La Jolla, CA 92093

ABSTRACT

Structural health monitoring and control have attracted much research interest in the last few decades. Traditional monitoring and control systems depend on the use of cables to transmit sensor data and actuation signals. With recent advances in wireless communication technology, wireless networks can potentially offer a low-cost alternative to traditional cable-based sensing and control systems. Another advantage of a wireless system is the ease of relocating sensors and controllers, thus providing a flexible and reconfigurable system architecture. However, compared to a cable-based system, wireless communication generally suffers more stringent limitations in terms of communication range, bandwidth, latency, and reliability. This paper describes the architectural design of a prototype wireless structural monitoring and control system. Although design criteria for sensing and control applications are different, state machine concepts prove to be effective in designing simple yet efficient communication protocols for wireless structural sensing and control networks. In wireless structural sensing applications, the design priority is to provide reliable data aggregation, while in wireless structural control applications, the design priority is to guarantee real-time characteristics of the system. The design methodologies have been implemented in a prototype wireless structural monitoring and control system, and validated through a series of laboratory and field experiments.

Keywords: structural health monitoring, structural control, wireless communication, finite state machine, information management.

1. INTRODUCTION

Ensuring the safety of civil structures, including buildings, bridges, dams, tunnels, and others, is important to society. Continuously subjected to loads and other environmental effects, the structural condition of many civil infrastructure systems in the U.S. is deteriorating. Structural health monitoring (SHM) systems have been proposed to predict, identify, and locate the onset of structural damage. Structural sensors, such as microelectromechanical system (MEMS) accelerometers, metal foil strain gages, fiber optic strain sensors, among others, have been developed and employed to collect important information about civil structures that could be used to infer the safety conditions or monitor the health of structures [1]. In addition to structural sensing and monitoring, control systems have been developed to mitigate excessive response of structures subjected to strong dynamic loads [2]. As opposed to monitoring applications where sensors are used in a passive manner to measure structural responses, feedback control systems require real-time system decision making based on structural response measurements.

In order to transfer real-time data in a structural monitoring or control system, coaxial cables are normally employed as the primary communication link. Cable installation is labor intensive and time consuming, and can cost as much as \$5,000 US dollars per communication channel [3]. To eradicate the high cost incurred by the use of cables, wireless systems could serve as a viable alternative [4]. Wireless communication standards, such as Bluetooth (IEEE 802.15.1), Zigbee (IEEE 802.15.4), Wi-Fi (IEEE 802.11b), are now mature and reliable technologies widely adopted in many industrial applications. Potential applications of wireless technologies in structural health monitoring have been explored by a number of researchers [5]. By incorporating an actuation interface, wireless sensors can be extended to potentially operate actuators for structural control applications [6].

* wyang98@stanford.edu; phone 1 650 723-6213; fax 1 650 725-9755; <http://eil.stanford.edu/wimms>

Compared to cable-based systems, wireless structural monitoring and control systems have a unique set of advantages and technical challenges. Besides the desire for portable long-lasting energy sources, such as batteries, reliable data communication is a key issue for implementation. Data transmission in a wireless network is inherently less reliable than that in cable-based systems, particularly when node-to-node communication ranges lengthen. The limited bandwidth for wireless devices can also impede real-time data transmission as required by feedback control systems. Last but not least, the time delay issue due to transmission and sensor blockage needs to be considered. These issues should be resolved by an integrated system approach involving the selection of hardware technologies and the design of software/algorithmic strategies.

The development of autonomous, self-sensing and actuating devices for structural monitoring and control applications represent an intriguing, interdisciplinary research challenge. The purpose of this paper is to describe the design and implementation of a modular system consisting of autonomous wireless sensing and actuation units for civil infrastructure applications. This wireless sensing and actuation unit can be used for both wireless structural health monitoring and real-time feedback structural control. Modularized software is designed for the wireless units, so that application software can be conveniently embedded into the units. The architectural details of the wireless structural monitoring and control system are presented. For different structural applications, special communication protocols have been designed to efficiently manage the information flow among the wireless units. Laboratory and field validation tests are conducted to assess the performance of the prototype wireless structural monitoring and control system.

2. ARCHITECTURE OF A WIRELESS SENSING AND ACTUATION UNIT

Sensing and actuation units are fundamental elements of a wireless monitoring and control network. The prototype wireless unit is designed in such a way that the unit can serve as either a sensing unit (i.e. a unit that collects data from sensors and wirelessly transmits the data), an actuation unit (i.e. a unit that calculates optimal control decisions and commands actuators), or a unit for both sensing and actuation. Fig. 1 shows the functional diagram of the prototype wireless sensing and actuation unit. The wireless sensing unit shown in the top part of Fig. 1 serves as a fundamental building block, where off-board modules for signal conditioning and signal generation can be easily incorporated.

The wireless sensing unit consists of three functional modules: sensor signal digitization, computational core, and wireless communication. The sensing interface converts analog sensor signals into digital data which is then transferred

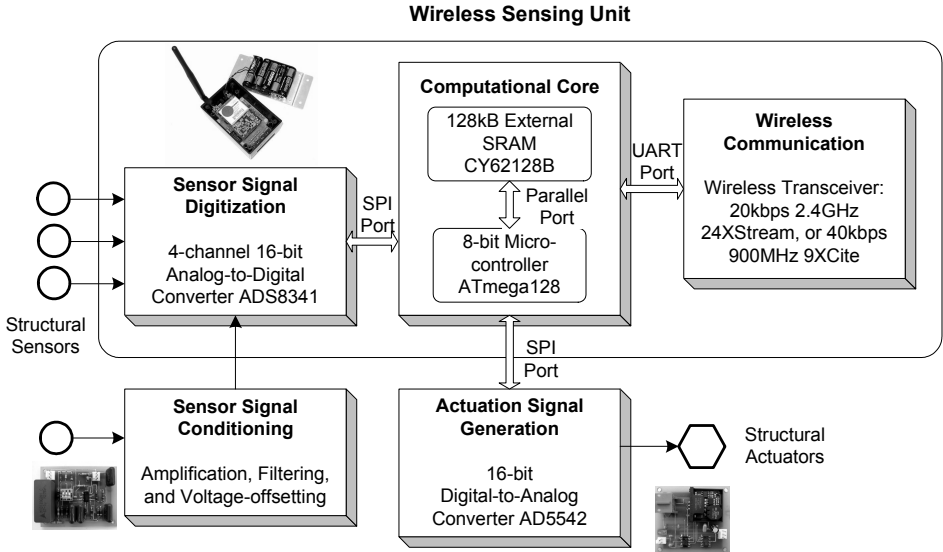

Fig. 1. Functional diagram detailing the hardware design of the wireless sensing unit. Additional off-board modules can be interfaced to the wireless sensing unit to condition sensor signals and issue actuation commands.

to the computational core through a high-speed Serial Peripheral Interface (SPI) port. Besides a low-power 8-bit Atmel ATmega128 microcontroller, external Static Random Access Memory (SRAM) is integrated with the computational core to accommodate local data storage and analysis. The computational core communicates with a wireless transceiver through a Universal Asynchronous Receiver and Transmitter (UART) interface. The auxiliary sensor signal conditioning module assists in amplifying, filtering, and offsetting analog sensor signals prior to digitization. The auxiliary actuation signal generation module offers an interface through which the wireless sensor can send analog control commands to structural actuators. Hardware details of the wireless unit and auxiliary modules are found in [6,7].

In order to manage the hardware components in a wireless sensing unit, software modules are implemented and embedded in the ATmega128 microcontroller. For the ATmega128 microcontroller, software can be written in a high-level programming language, such as C, compiled into binary instructions, and preloaded into the nonvolatile flash memory of the microcontroller. When the wireless unit is powered on for normal operation, the microcontroller automatically starts executing the embedded instructions. The software design of the wireless sensing and actuation units follows the hierarchical structure as shown in Fig. 2. At the bottom level are the software modules that manage the basic peripherals of the microcontroller. The middle layer consists of software modules that manage other onboard hardware components. Specific software modules for structural health monitoring and control are implemented in the top level application layer.

As shown in Fig. 2, the lowest level of the embedded software manages the peripherals of the ATmega128 microcontroller and serves as the fundamental modules to support the functions of other hardware components. Embedded modules include: timer interrupt functions, byte-by-byte communication through the UART and SPI ports, and internal memory management. The timer interrupt service implemented is employed to achieve a constant time step for sensor data sampling. The interrupt function is also a powerful feature that allows the software to momentarily pause an executing task (such as data processing or wireless communication) to sample data from the sensing interface according to a precise timing schedule. Immediately after servicing the sensing interface, the paused task is resumed and the program continues its execution. This timer interrupt feature is utilized to implement continuous data streaming from multiple wireless sensing units, where sensor data sampling has to occur at a constant sampling step amidst the execution of the wireless communication or data interrogation program. In effect, the software supports concurrency thereby allowing multiple software tasks to execute at the same time.

Building on top of the microcontroller peripherals are the software drivers that manage other hardware components in the wireless unit. Utilizing the UART peripheral, the wireless communication driver provides the following functions interfacing the microcontroller with the wireless transceiver: 1) reading or setting the radio parameters of the attached wireless transceiver; 2) sending or receiving data through the wireless transceiver; 3) implementing the state machine representing the wireless communication protocol. A driver module is implemented to manage the 128kB external Static Random Access Memory (SRAM). This module includes functions to enable and disable the external SRAM, as well as

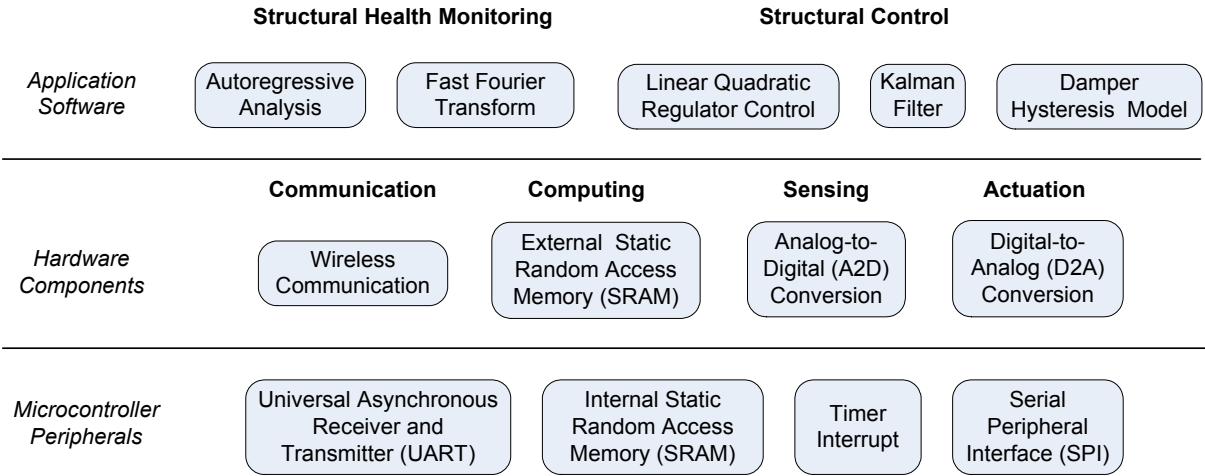

Fig. 2. Software layers of the ATmega128 microcontroller in the wireless sensing and actuation unit.

functions that allow access to the lower 64kB half or higher 64kB half of the memory chip. The other two hardware drivers, the A2D and the D2A modules, manage the interfaces with the structural sensors and actuators. The ATmega128 microcontroller provides only one SPI port, which is shared by both the A2D converter (ADS8341) for sensing and the D2A converter (AD5542) for actuation. The A2D module commands the ADS8341 to convert a 0 to 5V analog sensor signal into a 16-bit integer. Knowing the sensitivity and offset of the sensor signal, the microcontroller can then compute a floating-point number quantifying the physical parameter being measured by the sensor. Conversely, the D2A module takes a floating-point number between -5V and 5V as input, converts the number into a 16-bit integer, and pushes the integer to the AD5542 to output the corresponding actuation voltage signal.

Utilizing the hardware drivers for communication, computing, sensing, and actuation, software can be developed to support structural health monitoring and control applications. A number of engineering algorithms, such as Fast Fourier Transform (FFT), autoregressive (AR) analysis, linear quadratic regulator (LQR) control, and Kalman Filter, have been implemented and embedded in the wireless units. The ability to execute embedded application software allows the wireless sensing units to make and execute decisions. Onboard data processing also helps save energy resources (i.e. preserving precious battery power) by reducing wireless transmission of large amounts of raw sensor data. With the application software executing in the wireless unit, each unit acts as an autonomous node in a wireless monitoring and control network. This architecture of distributed sensing and actuation represents a new paradigm in structural health monitoring and control, as opposed to traditional centralized systems.

3. WIRELESS STRUCTURAL HEALTH MONITORING

The wireless unit is initially designed for applications in wireless structural health monitoring. This section first provides an overview to the wireless structural health monitoring system, and then introduces the communication protocol design for reliable data management in the prototype system.

3.1 Overview of the wireless structural health monitoring system

A simple star-topology network is adopted for the prototype wireless sensing system. A system includes a server and multiple structural sensors, signal conditioning modules, and wireless sensing units (Fig. 3). The server is used to organize and collect data from multiple wireless sensing units in the sensor network. The server is responsible for: 1) commanding all the corresponding wireless sensing units to perform data collection or interrogation tasks, 2) synchronizing the internal clocks of the wireless sensing units, 3) receiving data or analysis results from the wireless network, and 4) storing the data or results. Any desktop or laptop computer connected with a compatible wireless transceiver can be used as the server. As shown in Fig. 3, the server also provides Internet connectivity so that sensor data or analysis results can be viewed remotely from other computers over the Internet. Since the server and the wireless sensing units must communicate frequently with one another, portions of their software are designed in tandem to allow seamless integration and coordination.

At the beginning of each wireless structural sensing test, the server issues commands to all the units, informing the units to restart and synchronize. After the server confirms that all the wireless sensing units have restarted successfully, the

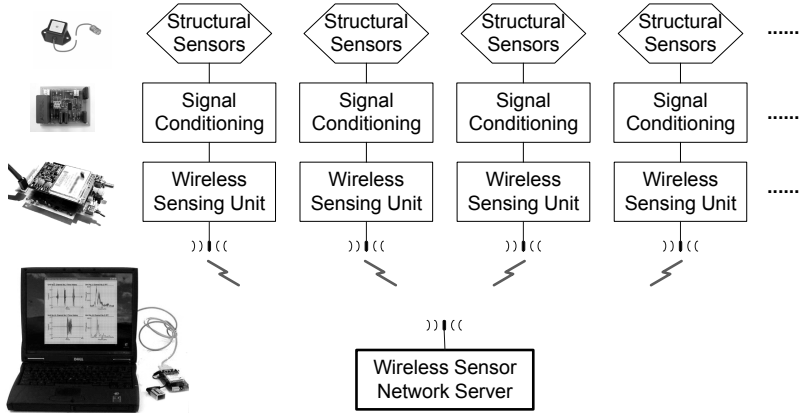

Fig. 3. An overview of the prototype wireless structural sensing system.

server queries the units one by one for the data they have thus far collected. Before the wireless sensing unit is queried for its data, the data is temporarily stored in the unit's onboard SRAM memory buffer. A unique feature of the embedded wireless sensing unit software is that it can continue collecting data from interfaced sensors in real-time as the wireless sensing unit is transmitting data to the server. In its current implementation, at each instant in time, the server can only communicate with one wireless sensing unit. In order to achieve real-time continuous data collection from multiple wireless sensing units with each unit having up to four analog sensors attached, a dual stack approach has been implemented to manage the SRAM memory [7]. When a wireless sensing unit starts collecting data, the embedded software establishes two memory stacks dedicated to each sensor channel for storing the sensor data. For each sensing channel, at any point in time, only one of the stacks is used to store the incoming data stream. While incoming data is being stored into the dedicated memory stack, the system transfers the data in the other stack out to the server. For each sensing channel, the role of the two memory stacks alternate as soon as one stack is filled with newly collected data.

3.2 Communication protocol design for the wireless structural health monitoring system

To ensure reliable wireless communication among the server and the wireless units, the communication protocol needs to be carefully designed and implemented. The commonly used network communication protocol is the Transmission Control Protocol (TCP) standard. TCP is a sliding window protocol that handles both timeouts and retransmissions. It establishes a full duplex virtual connection between two endpoints. Although TCP is a reliable communication protocol, it is too general and cumbersome to be employed by the low-power and low data-rate communication such as in a wireless structural sensing network. The relatively long latency of transmitting each wireless packet is another bottleneck that may slow down the communication throughput. For practical and efficient application in a wireless structural sensing network, a simpler communication protocol is needed to minimize transmission overhead. Yet the protocol has to be designed to ensure reliable wireless transmission by properly addressing possible data loss.

The communication protocol designed for the prototype wireless sensing system inherits some useful features of TCP, such as data packetizing, sequence numbering, timeout checking, and retransmission. Based upon pre-assigned arrangement between the server and the wireless units, the sensor data stream is segmented into a number of packets, each containing a few hundred bytes. A sequence number is assigned to each packet so that the server can request the data sequentially. To simplify the communication protocol, special characteristics of the structural health monitoring application are exploited. For example, since the objective in structural monitoring application is normally to transmit sensor data or analysis results to the server, the server is assigned the responsibility for ensuring reliable wireless communication. As the server program normally runs on a computer and the wireless unit program runs on a microcontroller, it is also reasonable to assign the responsibility to the server since it has much higher computing power. For example, communication is always initiated by the server. After the server sends a command to the wireless sensing unit, if the server does not receive an expected response from the unit within a certain time limit, the server will resend the last command again until the expected response is received. However, after a wireless sensing unit sends a message to the server, the unit does not check if the message has arrived at the server correctly or not, because the communication reliability is assigned to the server. The wireless sensing unit only becomes aware of the lost data when the server queries the unit for the same data again. In other words, the server plays an "active" role in the communication protocol while the wireless sensing unit plays more of a "passive" role.

Finite state machine concepts are employed in designing the communication protocol for the wireless sensing units and the server. A finite state machine consists of a set of states and definable transitions between the states [8]. At any point in time, the state machine can only be in one of the possible states. In response to different events, the state machine transits between its discrete states. The communication protocol for initialization and synchronization can be found in [7]. Fig. 4 shows the communication state diagram of the server for one round of sensor data collection, and Fig. 5 shows the corresponding state diagram of the wireless units. During each round of data collection, the server collects sensor data from all of the wireless units; note that the server and the units have separate sets of state definition.

At the beginning of data collection, the server is in State3 (Fig. 4) and all the units are also set in State 3 (Fig. 5). Starting with the first wireless unit in the network, the server queries the sensor for the availability of data in the current memory stack of that unit by sending '01Inquiry'. If the data is not ready, the unit replies '02NotReady', otherwise the unit replies '03DataReady' and transits to State4. After the server is certain that the data from this wireless unit is ready for collection, the server transits to State5. To request a data segment from a unit, the server sends a '04PlsSend' command that contains a packet sequence number. In case the server doesn't receive the requested data segment within a prescribed time window, the server resends the same request until the data arrives successfully. One round of data collection from one wireless unit is ended with a two-way handshake, where the server and the unit exchanges

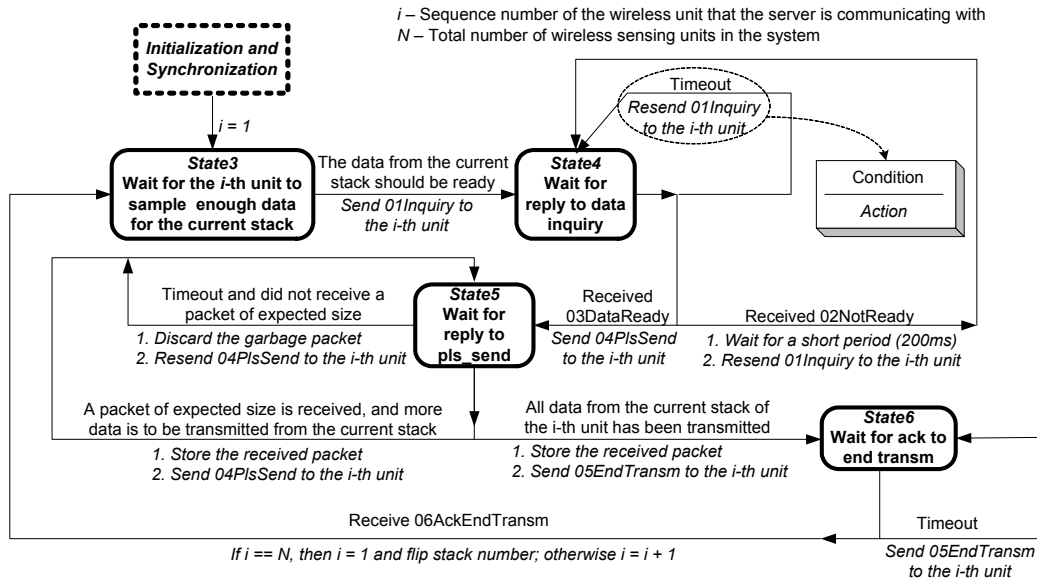

Fig. 4. Communication state diagram of the server.

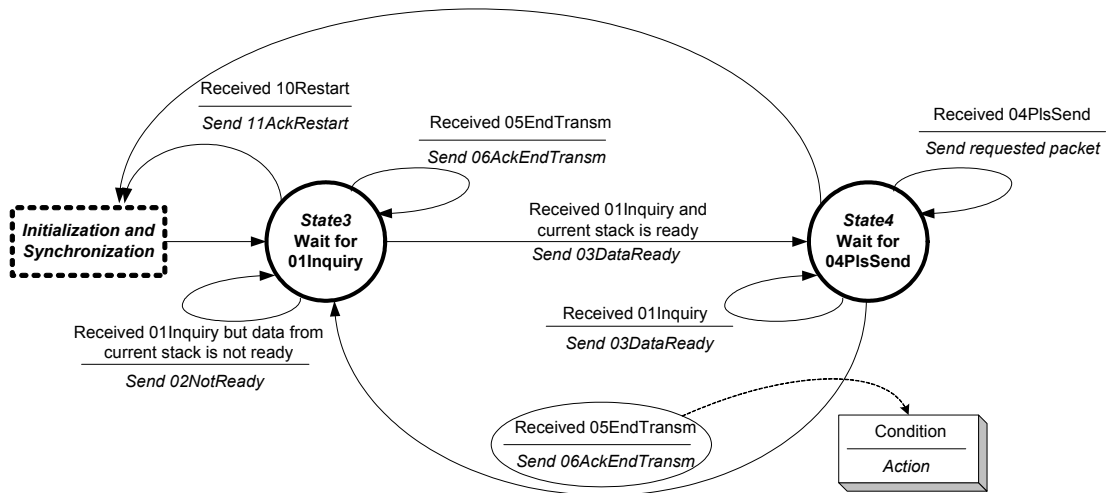

Fig. 5. Communication state diagram of the wireless units.

‘05EndTransm’ and ‘06AckEndTransm’. The server then moves on to the next unit and continuously collects sensor data round-by-round.

3.3 Field validation tests at Voigt Bridge

Laboratory and field validation tests have been conducted to verify the performance of the wireless structural monitoring system. Field tests are particularly helpful in assessing the limitations of the system, and providing valuable experience that can lead to further improvements in the system hardware and software design. This section presents an overview of the validation tests conducted on the Voigt Bridge located on the campus of the University of California, San Diego (UCSD) in La Jolla, California [10]. Voigt Bridge is a two lane concrete box girder highway bridge. The bridge is about 89.4m long and consists of four spans (Fig. 6). The bridge deck has a skew angle of 32°, with the concrete box-girder supported by three single-column bents. Over each bent, a lateral diaphragm with a thickness of about 1.8m stiffens the girder. Longitudinally, the box girder is partitioned into five cells running the length of the bridge (Fig. 6b).

As a testbed project for structural health monitoring research, a cable-based system has been installed in the northern-most cells of the box girder [10]. The cable-based system includes accelerometers, strain gages, thermocouples, and humidity sensors. The following briefly describes the wireless monitoring tests for determining the operating deflection shapes of the bridge deck. For this purpose, twenty wireless accelerometers and the wireless network server are mounted to the bridge sidewalks (Fig. 6a). The communication distance between the server and the farthest wireless sensing unit is close to the full length of the bridge. The installation and calibration of the wireless monitoring system, including the placement of all the wireless sensors, takes about an hour. The Maxstream 9XCite wireless transceiver operating at 900MHz (allowed by US government regulations) is integrated with each wireless sensing unit. Two types of accelerometers are employed in the wireless monitoring system, including PCB Piezotronics 3801 accelerometers and Crossbow CXL02LF1Z accelerometers. Signal conditioning modules are used for filtering noise, amplifying and shifting signals for the wireless accelerometers. Sampling frequency for the wireless monitoring system is 200 Hz.

The communication protocol described before is implemented in the server and the wireless sensing units. For the tests described in this paper, the server collects sensor data or FFT results from all 20 wireless units. Due to the length of the bridge and continuous traffic conditions, the wireless communication experienced some intermittent difficulty during the two days of field testing. However, the wireless monitoring system proved robust by recognizing communication failures and successfully retransmitting the lost data according to the communication protocol rules. Fig. 7 shows the operating deflection shapes (ODS) extracted from one set of test data collected during a hammer excitation test. The hammer excitation is applied at the location shown in Fig.6(a) and during intervals of no passing vehicles. DIAMOND, a modal analysis software package, is used to extract the operating deflection shapes (ODS) of the bridge deck [11]. Under hammer excitation, the operating deflection shapes at or near a resonant frequency should be dominated by a single mode shape [12]. Fig. 7 presents the first four dominant operating deflection shapes of the bridge deck using

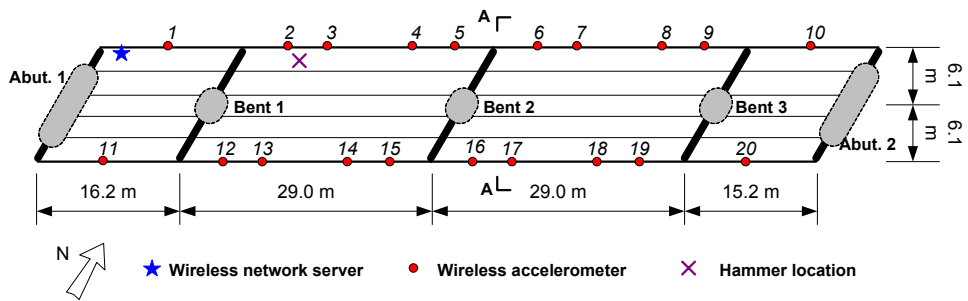

(a) Plan view of the bridge illustrating locations of wireless accelerometers.

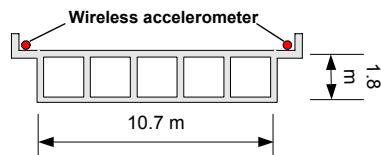

Section A-A
(b) Elevation view to section A-A.



(c) Side view of the bridge over Interstate 5.

Fig. 6. Voigt Bridge on the campus of the University of California, San Diego.

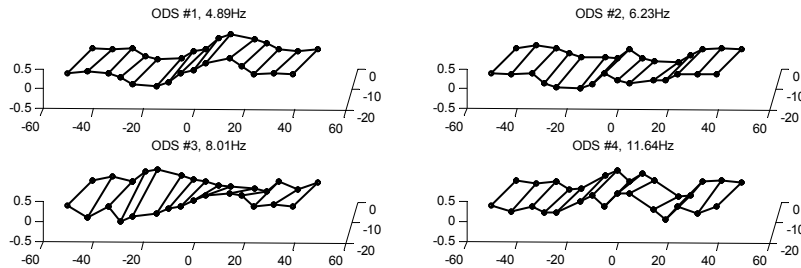

Fig. 7. Operating deflection shapes extracted from wireless sensor data.

wireless acceleration data. The ODS #1 (4.89 Hz), #2 (6.23 Hz), and #4 (11.64 Hz) show primarily flexural bending modes of the bridge deck; a torsional mode is observed in ODS #3 (8.01 Hz). Successful extraction of the ODS shows that the acceleration data from the 20 wireless units are well synchronized.

4. WIRELESS STRUCTURAL CONTROL

As described in Section 2, the wireless sensing and actuation units can also serve as building blocks for a wireless structural control network intended for real-time feedback control. This section gives an overview to the wireless control system, introduces the communication protocol design for real-time data delivery, and then briefly presents validation test results using a three-story steel frame structure instrumented with magnetorheological (MR) dampers.

4.1 Overview of the wireless structural control system

Fig. 8 illustrates the communication patterns of a centralized control system using cabled communication and the prototype decentralized structural control system using wireless communication. In a centralized control system, one centralized controller collects data from all the sensors in a structure, computes control decisions, and then dispatches actuation signals to actuators. This centralized control strategy implemented with cabled communication requires high instrumentation cost, is difficult to reconfigure, and potentially suffers from single-point failure at the controller. Wireless decentralized control architectures can offer an alternative solution. In a decentralized architecture, multiple sensors and controllers can be distributively placed in a large structure, where the controller nodes can be closely collocated with the system actuators. As each controller only needs to communicate with sensors and actuators in its vicinity, the requirement on communication range can be significantly reduced, and the communication latency decreases by reducing the number of sensors or actuators that each controller has to communicate with.

In discrete-time feedback control, a steady sampling time step and low communication latency are essential for the system performance. The feedback control loop designed for the prototype wireless sensing and control system is illustrated in Fig. 9a, and the pseudo code implementing the feedback loop is presented in Fig. 9b. As shown in the figures, sensing is designed to be clock-driven, while control and actuation are designed to be event-driven. The wireless sensing nodes collect sensor data at a preset sampling rate, and transmit the data during the assigned time slot. Upon receiving the required sensor data, the control/actuation nodes immediately compute control decisions and apply the corresponding actuation signals to the actuators. If a control/actuation node doesn't receive the expected sensor data at one time step, it may use a previous data sample for control decisions, or doesn't take any action at all.

4.2 Communication protocol design for the wireless structural control system

Similar to the structural monitoring application, a reliable communication protocol must be properly designed for the wireless structural control system. For illustration purpose, a 3-story structure instrumented with the prototype wireless control system is shown in Fig. 10a. The system consists of wireless sensors and controllers that are mounted on the structure for measuring structural response data and commanding MR dampers in real-time. Besides the wireless sensing and control units that are necessary for data collection and the operation of the actuators, a remote command server with a wireless transceiver is also included for experimental purpose (e.g. passive data logging). In a laboratory setup, the server is designed to initiate the operation of the control system and to log the data flow in the wireless

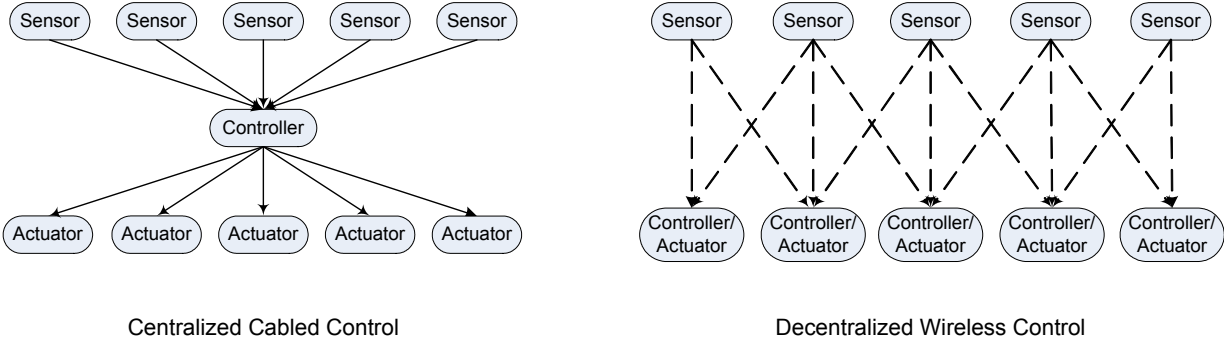
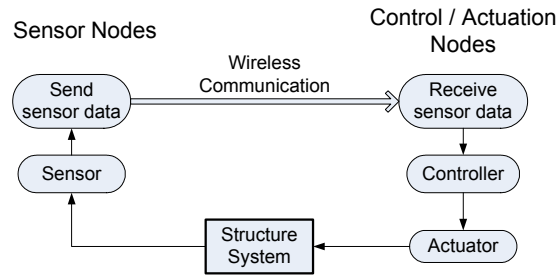

Fig. 8. Centralized and decentralized control systems.



(a) Feedback control loop between the sensing nodes and control/actuation nodes

| Sensing Nodes (Clock-driven) | Control / Actuation Nodes (Event-driven) |
|------------------------------------|--|
| ITERATE { | ITERATE { |
| Wait for the assigned time slot. | IF (sensor data arrived on time) |
| Sample sensor data. | Compute control decisions. |
| Wirelessly transmit sensor data. → | Apply actuation signal. |
| } | ELSE |
| | Use previous data sample or no action. |
| | Wait for the wireless sensor data. |
| | } |

(b) Pseudo code for the feedback control loop

Fig. 9. Illustration of the feedback control loop in a wireless decentralized control system.

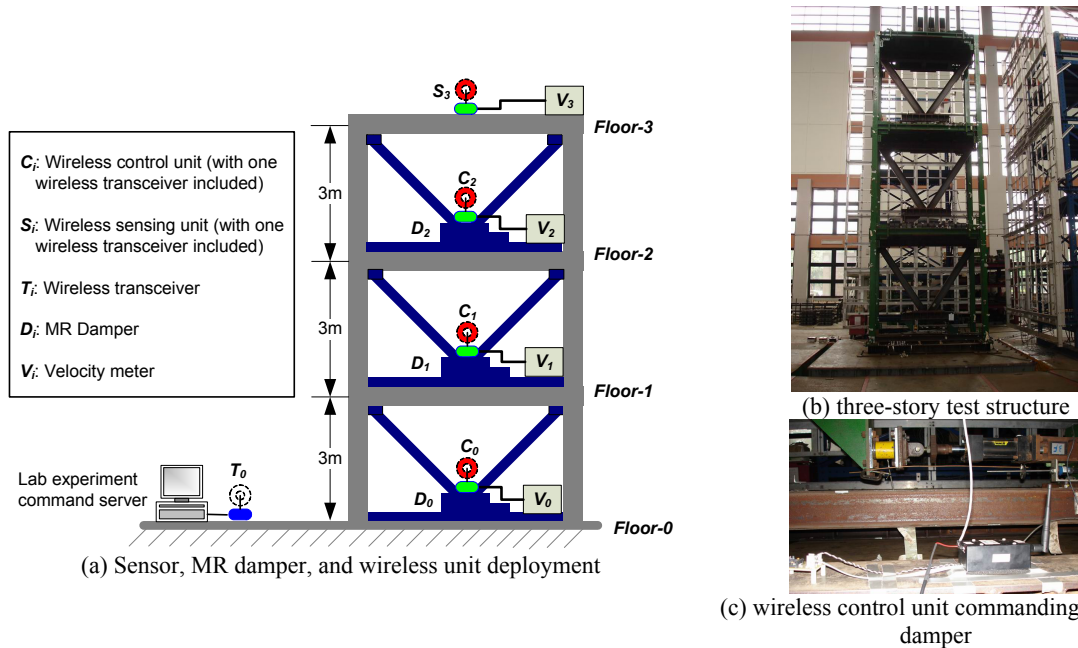

Fig. 10. Laboratory setup of the wireless structural control system.

network. To initiate the operation, the command server first broadcasts a start signal to all the wireless sensing and control units. Once the start command is received, the wireless units that are responsible for collecting sensor data start acquiring and broadcasting data at a preset time interval. Accordingly, the wireless units responsible for commanding the actuators receive the sensor data, calculate desired control forces, and apply control commands within the specified time interval.

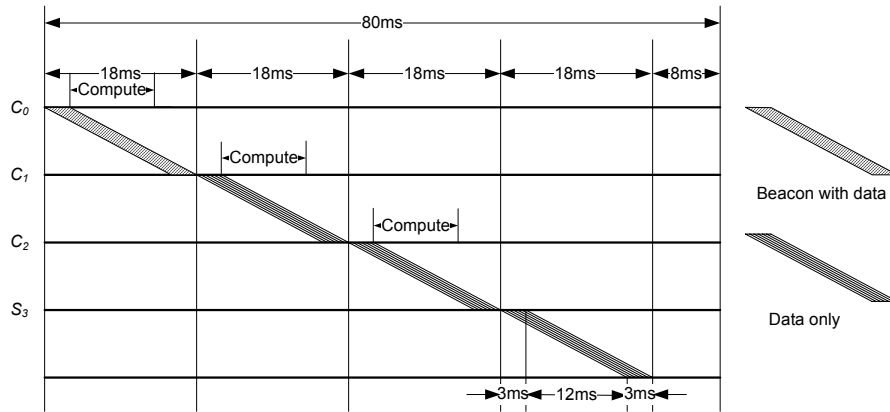

Fig. 11. Communication sequence in a wireless structural control network.

To coordinate the wireless transmissions during the feedback control, a pre-specified communication sequence should be observed by all the wireless units. For example, if all three wireless control units need velocity data from all the floors to compute control decisions, a communication sequence illustrated in Fig. 11 can be adopted by the prototype system. The control sampling step, which is 80ms in this example, is mostly decided by the total time required for transmitting all four data packets. For the 24XStream wireless transceiver adopted in the system, wireless transmission of each velocity measurement takes about 18ms. During every control time step, the wireless unit C_0 first samples the velocity data V_0 at its own floor, and then sends out the data together with a beacon signal to other wireless units. Upon receiving the beacon signal, units C_1 , C_2 , and S_3 sequentially broadcast their sensor data. Last, a period of 8ms is designed as a safety cushion for each control sampling time step, allowing certain randomness in the wireless transmission time. The control units C_0 , C_1 , and C_2 compute control decisions and apply actuation signals during the intervals of wireless transmissions concurrently.

Similar to the wireless monitoring system design, finite state machines are constructed for the command server and the wireless sensing and actuation units. The state machines are designed in tandem so that the server and the wireless units can follow the basic steps for initialization, synchronization, and real-time feedback control. Robust communication is designed during the initialization and synchronization by timeout check and retransmission. However, to support real-time feedback control, no timeout check and retransmission is performed during the feedback loop.

4.3 Validation tests to the wireless structural control system

Validation experiments for the wireless control system were conducted at the National Center for Research on Earthquake Engineering (NCREE) in Taipei, Taiwan. A three-story steel frame structure is designed and constructed by researchers affiliated with NCREE (Fig. 10b). The floor plan of this structure is $3\text{m} \times 2\text{m}$, with each floor weight adjusted to 6,000 kg using concrete blocks; inter-story heights are 3m. The three-story structure is mounted to a $5\text{m} \times 5\text{m}$ 6-DOF shake table. For this study, only longitudinal excitation in one degree of freedom is employed in the tests. Accelerometers, velocity meters, and linear variable displacement transducers (LVDT) are installed on each floor of the structure; these sensors are interfaced to a high-precision tethered data acquisition (DAQ) system native to the facility.

For this experimental study, three 20 kN MR dampers are installed in a V-brace upon each story of the steel structure (Fig. 10b). The damping coefficients of the MR dampers can be changed by issuing a command voltage between 0V to 1.2V. This command voltage determines the electric current of the electromagnetic coil inside the MR damper, which in turn, generates a magnetic field that sets the viscous damping properties of the MR damper fluid [13]. Two control systems are installed in the test structure: the wireless control system and a traditional wire-based control system. For the wireless system, a total of four wireless sensors are installed (Fig. 10). Centralized velocity feedback control algorithms presented in a previous paper are used for both the wired and the wireless control systems [14]. For the test structure, the wire-based system can achieve a sampling rate of 200Hz. As shown in Fig. 11, the wireless system can achieve a sampling rate of 12.5Hz.

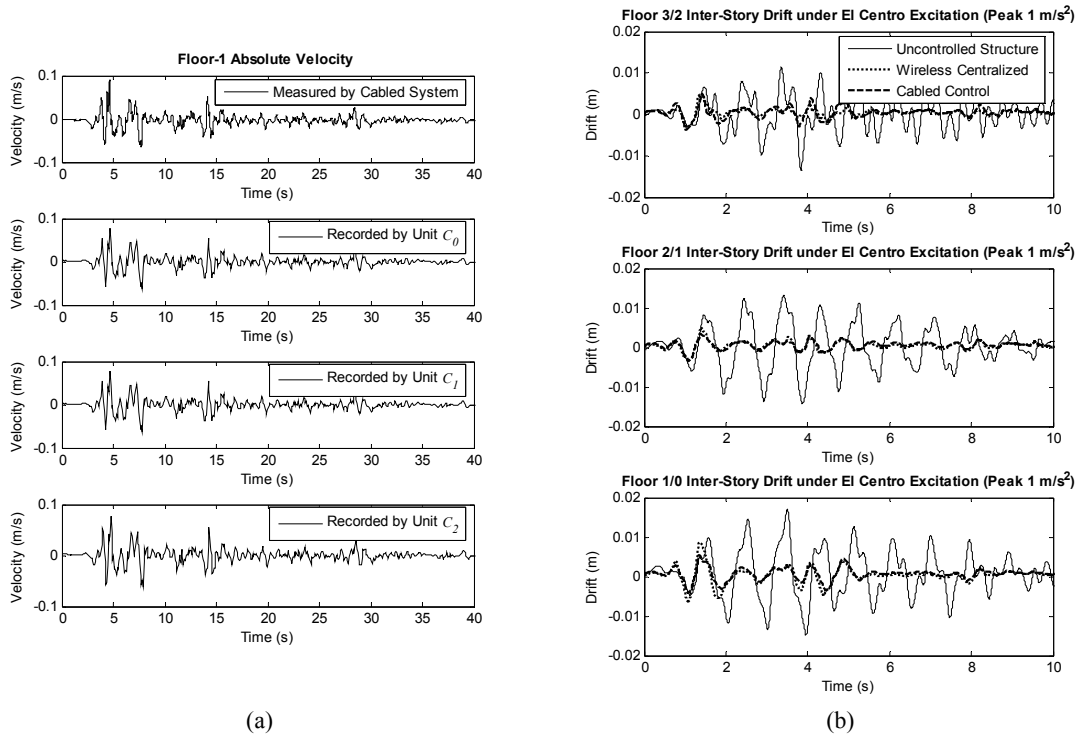

Figure 12. Experimental time histories for: (a) Floor-1 absolute velocity data recorded by the cabled and wireless sensing systems; (b) inter-story drifts of the structure with and without control.

To illustrate the reliability of real-time feedback control using wireless sensors, Fig. 12(a) presents the Floor-1 time history data during one test run. The ground excitation in this test is the 1940 El Centro NS earthquake record scaled to a peak ground acceleration of 1 m/s^2 . The data is collected separately by the cabled DAQ system and recorded by the three wireless control units. During the test, unit C_1 measures the data from the velocity meter at Floor-1, stores the data in its memory bank, and transmits the data wirelessly to unit C_0 and C_2 . After the test run is completed, data from all the three control units are sequentially streamed to the experiment command server, where the results are plotted as shown in Fig. 12(a). These plots illustrate strong agreement among data recorded by the three wireless control units and by the cabled system using a separate set of velocity meters. These results show that the velocity data is not only reliably measured by unit C_0 , but also properly transmitted to the other wireless control units in real-time. The time histories of the inter-story drifts from the same wireless test are plotted in Fig. 12(b), together with the drifts of a centralized wired control test and a dynamic test when the structure is not instrumented with any control system (i.e. without the MR dampers). The same ground excitations are used for all three cases shown in Fig. 12(b). The results show that both the wireless and wired control systems achieve considerable gain in limiting inter-story drifts. Running at a much shorter sampling time step, the wired centralized control system achieves slightly better control performance than the wireless centralized system in terms of mitigating inter-story drifts.

5. SUMMARY AND CONCLUSION

This paper describes the design and implementation of information management in a wirelessly networked system that consists of autonomous wireless sensing and actuation units. The wireless units can be used for both wireless structural health monitoring and real-time feedback structural control. For different structural applications, special communication protocols have been designed to efficiently manage the information flow among the wireless units. State machine concepts prove to be effective in designing simple yet efficient communication protocols for wireless structural sensing

and control networks. Laboratory and field validation tests illustrate the efficacy and robustness of the information management in the prototype wireless structural monitoring and control system.

6. ACKNOWLEDGEMENT

This research is partially funded by the National Science Foundation under grants CMS-9988909 (Stanford University) and CMS-0421180 (University of Michigan), and the Office of Naval Research Young Investigator Program awarded to Prof. Lynch at University of Michigan. The first author is supported by an Office of Technology Licensing Stanford Graduate Fellowship. Dr. Pei-Yang Lin, and Mr. Kung-Chun Lu at National Taiwan University provided generous support for conducting the shake table experiments at NCREE, Taiwan. The authors would also like to express their gratitude to Dr. Michael Fraser of the University of California, San Diego, for access to Voigt Bridge.

REFERENCES

1. C. R. Farrar, H. Sohn, F. M. Hemez, M. C. Anderson, M. T. Bement, P. J. Cornwell, S. W. Doebling, J. F. Schultze, N. Lieven, A. N. Robertson, *Damage Prognosis: Current Status and Future Needs*, Report LA-14051-MS, Los Alamos National Laboratory, NM, 2003.
2. T. T. Soong and B. F. Spencer Jr., "Supplemental Energy Dissipation: State-of-the-art and State-of-the-practice," *Engng. Struct.* 24, 243-259, 2002.
3. M. Celebi, *Seismic Instrumentation of Buildings (with Emphasis on Federal Buildings)*, Report No. 0-7460-68170 United States Geological Survey (USGS). Menlo Park, CA, 2002.
4. E. G. Straser and A. S. Kiremidjian, *A Modular, Wireless Damage Monitoring System for Structures*, Report No. 128, John A. Blume Earthquake Eng. Ctr., Stanford University, Stanford, CA, USA, 1998.
5. J. P. Lynch and K. Loh, "A Summary Review of Wireless Sensors and Sensor Networks for Structural Health Monitoring," *Shock Vib. Dig.*, Sage Publications, 38(2), 91-128, 2005.
6. Y. Wang, A. Swartz, J. P. Lynch, K. H. Law, K.-C. Lu, and C.-H. Loh, "Wireless Feedback Structural Control with Embedded Computing," *Proc. of the SPIE 11th Intl. Symposium on Nondestructive Evaluation for Health Monitoring and Diagnostics*, San Diego, CA, USA, Feb 26 - Mar 2, 2006.
7. Y. Wang, J. P. Lynch, and K. H. Law, "A Wireless Structural Health Monitoring System with Multithreaded Sensing Devices: Design and Validation," *Structure and Infrastructure Engineering - Maintenance, Management and Life-Cycle Design & Performance*, 3(2), 103-120, 2006.
8. D. Tweed, "Designing Real-time Embedded Software using State-machine Concepts," *Circuit Cellar Ink*, 53, 12-19, 1994.
9. Y. Wang, K. J. Loh, J. P. Lynch, M. Fraser, K. H. Law, and A. Elgamal, "Vibration Monitoring of the Voigt Bridge using Wired and Wireless Monitoring Systems," *Proc. of the 4th China-Japan-US Symposium on Structural Control and Monitoring*, Hangzhou, China, Oct 15 - 16, 2006.
10. M. Fraser, A. Elgamal, J. P. Conte, *UCSD Powell Laboratory Smart Bridge Testbed*. Report No. SSRP 06/06, Department of Structural Engineering, University of California, San Diego, La Jolla, CA, USA, 2006.
11. S. W. Doebling, C. R. Farrar, P. J. Cornwell, "DIAMOND: A Graphical User Interface Toolbox for Comparative Modal Analysis and Damage Identification", *Proc. of 6th International Conference on Recent Advances in Structural Dynamics*, Southampton, UK, Jul 1997.
12. M. H. Richardson, "Is it a Mode Shape or an Operating Deflection Shape?" *Sound and Vibration Magazine*, 31, 54-61, 1997.
13. P.-Y. Lin, P. N. Roschke, and C.-H. Loh, "System Identification and Real Application of a Smart Magnetorheological Damper," *Proc. of the 2005 International Symposium on Intelligent Control*, Limassol, Cyprus, Jun 27-29, 2005.
14. Y. Wang, R. A. Swartz, J. P. Lynch, K. H. Law, K.-C. Lu, and C.-H. Loh, "Decentralized Civil Structural Control using a Real-time Wireless Sensing and Control System," *Proc. of the 4th World Conf. on Structural Control and Monitoring (4WCSCM)*, San Diego, CA, USA, Jul 11 - 13, 2006.